

Digital control electronics for the axial piston pumps A4VS... with HS4 control and A2V... with EO4 control

Type VT-VPCD

RE 30028

Edition: 2013-07

Replaces: 2012-06

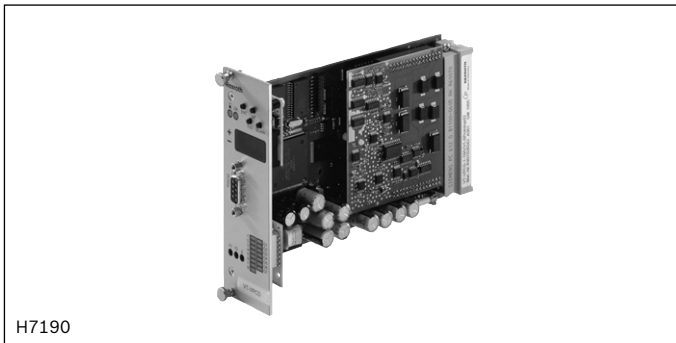

- ▶ Component series 1X
- ▶ The HS4 or EO4 control is used for the electro-hydraulic swivel angle and pressure control as well as for the power limitation of axial piston variable displacement pumps.

Features

The control system with HS4 control consists of the following assemblies:

- ▶ A4VS...HS4 axial piston pump with attached 4WRE6-2X/822 proportional valve including position transducer for swivel angle and valve position sensing
- ▶ Recommended pressure transducer HM20-2X for recording the system pressure
- ▶ VT-VPCD control electronics to implement all electrical functions necessary for HS4 control

The control system with EO4 control consists of the following assemblies:

- ▶ A2V...EO4 axial piston pump (housing and/or installation pump) with attached proportional valve including position transducers for swivel angle and valve position sensing
- ▶ Recommended pressure transducer HM20-2X for recording the system pressure
- ▶ VT-VPCD control electronics to implement all electrical functions necessary for the EO4 control

Parameterization is effected via a serial interface. The user-specific data can be exactly reproduced and is protected against unintended or unauthorized adjustment.

Continued on page 2

Contents

Features	1
Ordering code	2
Functional description using the axial piston pump A4VS with HS4 control as an example	3
Static characteristic curves	4
Transition function with swivel angle command value step	4
Functional description of the control electronics	5
Block diagrams and pin assignment	7
Pin assignment of the D-Sub sockets on the front plate	13
Dimensions	13
Technical data	14
Project planning/maintenance instructions/ additional information	16

Features (continued)

- ▶ Digital inputs for calling pre-set parameters ¹⁾
- ▶ Ramp times for swivel angle and pressure command values ¹⁾
- ▶ Analog inputs for command and actual values ¹⁾
- ▶ Enable input and collective fault output ¹⁾
- ▶ Oscillators/demodulators for two inductive measuring systems
- ▶ Clocked, flow-controlled output stage
- ▶ Switching power supply unit for the internal supply voltages
- ▶ Function and status display LEDs
- ▶ 2 measuring sockets configurable via display and/or Bodac
- ▶ Serial interface RS 232
- ▶ Up to 32 control electronics can be interconnected for parameterization and diagnosis via the local bus
- ▶ Size selection (size 40 to 1000 for A4VS...HS4, size 500 to 1000 for A2V...EO4) and parameterization via BODAC
- ▶ Parameterization for pump A4VHO 450 HS4
- ▶ Valve position controller
- ▶ Pressure controller with subordinate swivel angle controller
- ▶ Parameterizable power limitation
- ▶ Leakage compensation
- ▶ Master/slave capability
- ▶ Mooring capability
- ▶ Oscilloscope function
- ▶ Parameterizable test output
- ▶ Diagnosis display

¹⁾ Please note the respective bus documentation.

Ordering code

01	02	03	04	05	06
VT-VPCD	-	1	-	1X	/
			/	1	-
				-	1

01	Digital control electronics for controlling axial piston variable displacement pumps	VT-VPCD
02	Component series 10 to 19 (10 to 19: Unchanged installation and connection dimensions)	1X
03	For axial piston pump A4VS...HS4 with swivel angle sensor AWX F004 D01 and for axial piston pump A2V...EO4 (housing pump) with swivel angle sensor MCP-40/4742	V0
	For axial piston pump A2V...EO4 (installation pump) with swivel angle sensor DK 100 (only available without bus connection)	V100
04	With display	1
05	Without bus connection	0
	PROFIBUS DPV0	P
	DeviceNet	D
	CANopen	C
06	With valve output stage	1

Preferred types	Material number
VT-VPCD-1-1X/V0/1-0-1	R901044346
VT-VPCD-1-1X/V0/1-P-1	R901089559

PC system requirements:

- ▶ Windows XP, Windows Vista, Windows 7
- ▶ RAM (recommendation: 256 MB)
- ▶ 250 MB of available hard disk capacity

Required accessories:

- ▶ PC program BODAC: CD ordering information: SYS-HACD-BODAC-01 (R900777335) or free download on the Internet at www.boschrexroth.com/vpcd
- ▶ Interface cable: Cable set VT-HACD-1X/03.0/HACD-PC (R900776897) or standard 1:1 cable

Suitable card holder:

- ▶ 19 inch racks VT 19101, VT 19102, VT 19103 and VT 19110 (see data sheet 29768)
- ▶ Open card holder VT 3002-2X/64G (see data sheet 29928), mat. no. R900991843 (only for control cabinet installation!)
- ▶ Connection adapter VT 10812-2X/64G (see data sheet 30105), mat. no. R900713826

Functional description using the A4VS axial piston pump with HS4 control as an example

The swivel angle and pressure control as well as the power limitation of the A4VS... variable displacement pump are effected by an electrically controlled proportional valve (1). Via the actuating piston (2) of the pump, this valve determines the position of the swash plate (3).

If the pump does not rotate, in case of depressurized high-pressure and actuating system and if enable is not operated, the swash plate is held in the "Zero" swivel angle position by the spring centering.

The position of the swash plate is determined by an inductive position transducer (4), the actual pressure value is recorded by a pressure transducer. Both actual values are supplied to the VT-VPCD control electronics and linked with each other by the software.

The actual power value is calculated from the product of actual pressure value and actual swivel angle value. The controller software ensures by means of a minimum value generator that the controller corresponding to the working point is always active.

In the static condition (i.e. swivel angle command value equals actual swivel angle value, power command value equals actual power value or pressure command value equals actual pressure value) the valve control spool is in central position.

If the superior controllers demand e.g. an increase in the swivel angle (corresponds to an increase in the flow), the valve control spool must be deflected out of the central position until the swivel angle has reached the required value.

The sectional drawing shows the A4VS... variable displacement pump with HS4 control; the proportional valve (1) is controlled using the VT-VPCD control electronics.

Notice for the HS4 control:

With de-energized proportional valve and pump with clockwise rotation and if the actuating pressure is available, the pump swivels to swivel angle $\alpha = 0$ (A4VSO design) or $\alpha = -100\%$ (A4VSG design).

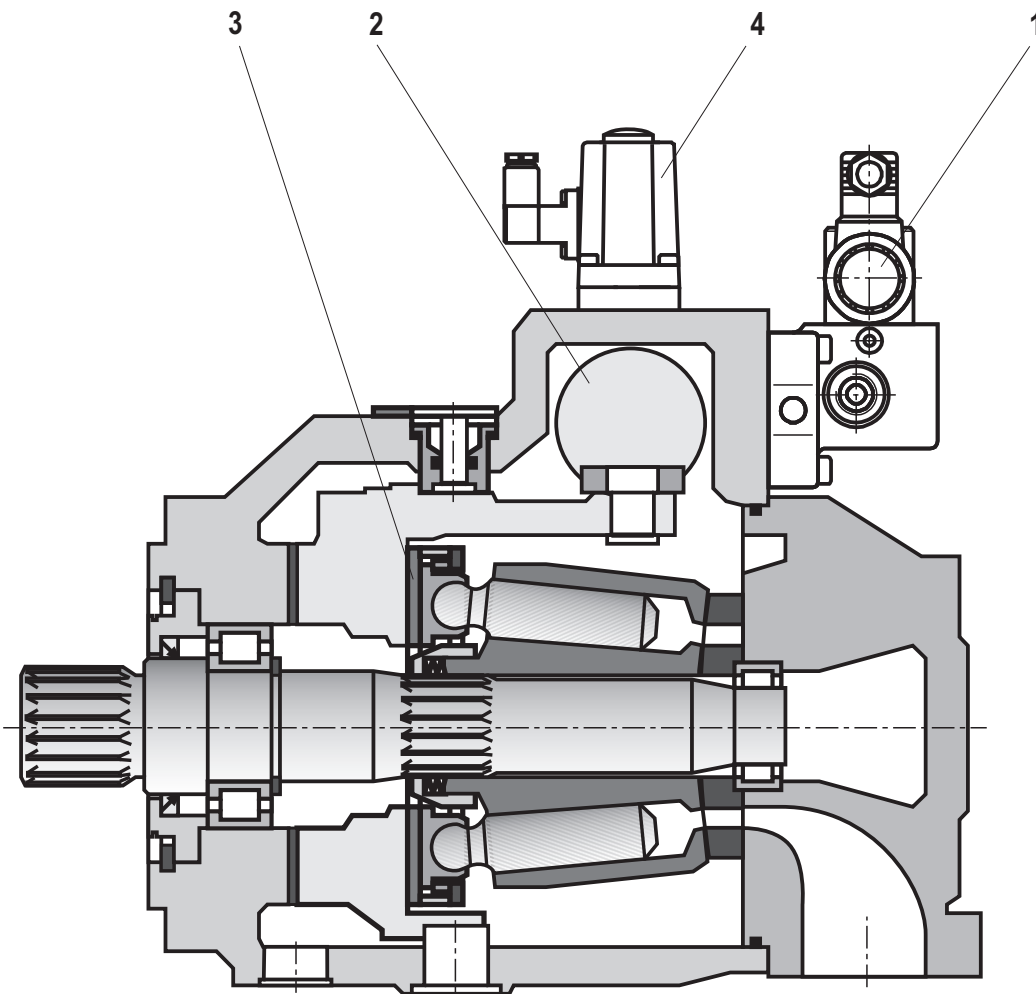

Static characteristic curve

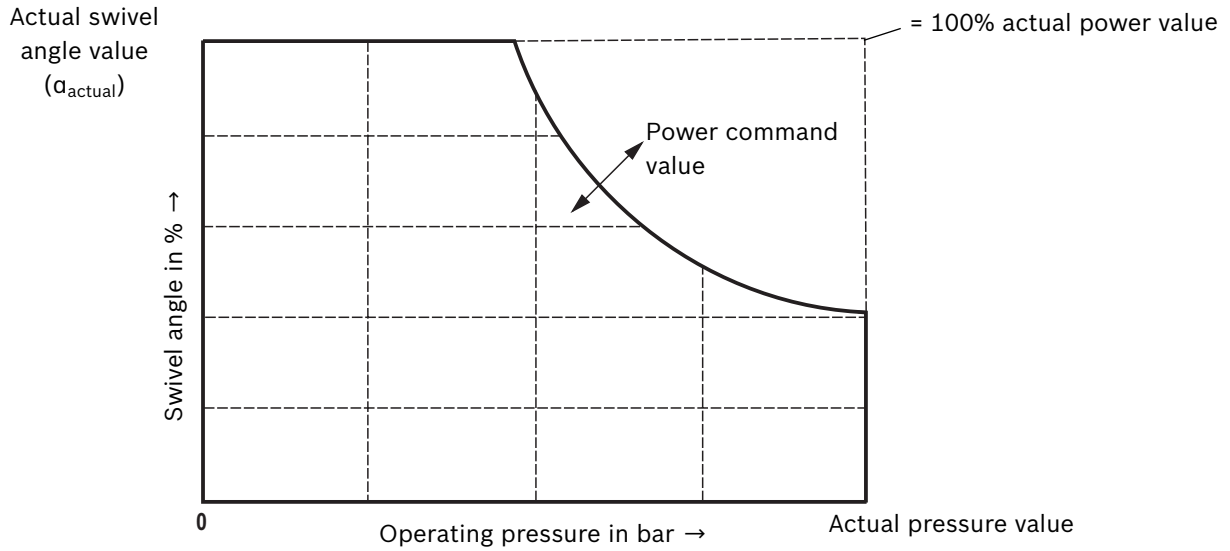

Transition function with swivel angle command value step

Example A4VS with HS4 control, size 250, actuating pressure $p = 125$ bar

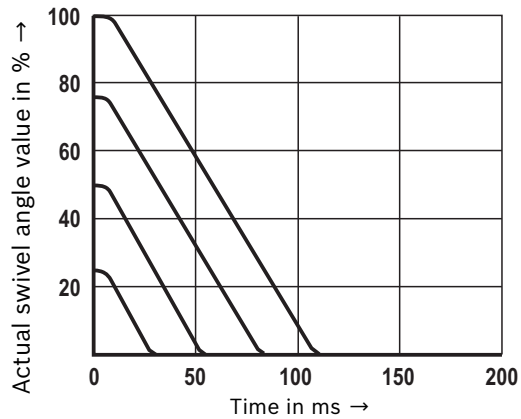
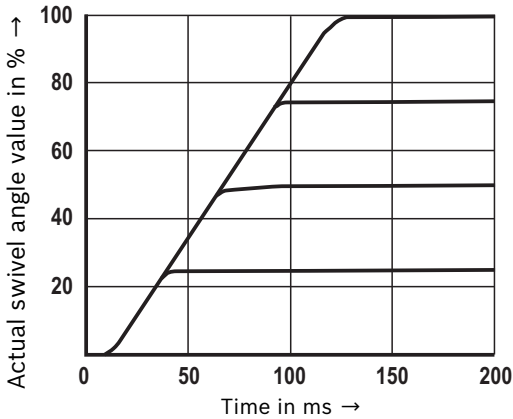

Functional description of the control electronics

The control electronics is set-up as printed circuit board in Europe format 100 x 160 mm, fitted on both sides. It comprises a switching power supply unit [1] creating all internally required voltages.

The central unit is a microcontroller controlling the entire process and realizing the controller functions. Data for configuration, command values and parameters are stored in a FLASH in a non-volatile form.

Four binarily coded digital inputs are used to call up parameter sets (command values) from the memory in which you can store a maximum of 16 sets. A call-up activates a command value for the swivel angle, the pressure and the power limitation as well as ramp times for swivel angle and pressure.

More control inputs have the following functions:

"Command value valid":	Release of the parameter set addressed by the current call-up (H active)
"Enable":	Activation of the control (H active)
Comment:	H active = High active (level 16 V to U_B) L active = Low active (level 0 V to 5 V) L/H edge = Low High edge

Via the differential inputs AI7, AI5 and AI4 [3], the analog command values for the swivel angle, the pressure and the maximum power are specified. With a positive swivel angle command value, the pump swivels in "counterclockwise" swivel direction (= flow direction P → B). The digital call-up command values are added to the analog command values; the total of both command values is supplied to the controller input via the relevant ramp generators.

The controller output signal controls the output stage [6] depending on the command/actual value differences.

The position of the valve control spool [11], the swivel angle of the variable displacement pump [12a, 12b or 12c] and the system pressure [13] are measured and supplied to the control loop via evaluation electronics [7].

For the pressure control, different modes are provided:

Depending on the configuration, the pressure controller works with one or two pressure sensors.

- ▶ Open circuit:
 - 1 sensor, optionally current or voltage
- ▶ Closed circuit:
 - 2 sensors, optionally current or voltage

In the closed circuit, both pressure sensors are evaluated. As soon as the control electronics is in pressure control, the larger of the two pressures determines the control behavior. To compensate control deviations (pressure command value-actual pressure value), the pressure controller can also swivel the pump to the opposite side as well as beyond its specified swivel angle command value.

The switching outputs are configured via BODAC.

The following functions may be selected:

- | | |
|---------------------------------------|-----|
| ▶ Swivel angle control active | DO1 |
| ▶ Pressure control active | DO2 |
| ▶ Power limitation active | DO3 |
| ▶ Slave mode active | DO4 |
| ▶ Swivel angle in the accuracy window | DO5 |
| ▶ Pressure in the accuracy window | DO6 |
| ▶ Rectangular 32 Hz | DO7 |

The test output (b26 or measuring socket X1) is also configured via BODAC. It is used for the analog output of internal variables.

Enable and error messages

Setting the enable input activates the control. If no command value call-up is activated, parameter set 0 is set.

Error logics identify the following faults:

- ▶ Cable brake or short circuit in the actual valve value recording
- ▶ Cable brake or short circuit in the actual swivel angle value recording
- ▶ Cable break at the pressure transducer (only current interface)
- ▶ Closed-loop errors (i.e. control deviations between swivel angle command value and actual swivel angle value)

An error is displayed at output d22. The "OK" message goes out, signal level is 0 V.

Errors are also shown at the display.

Parameterization and diagnosis

Using the serial interface [2], the pump size is selected and the leakage oil correction and the sequence control are activated or deactivated and switching outputs and the test output are configured via BODAC at the front-side D-Sub socket. Via the local bus, up to 32 control electronics can be connected. Via BODAC, every control electronics is assigned a bus address. Reconnection of the serial interface cable is not required. More information in document 30028-01-B.

Display elements and measuring sockets

The freely configurable measuring sockets X1/X2 located at the front plate serve to display the process signals. Configuration see online help.

LEDs display the following states:

LED "I" (green):	Enable active
LED "OK" (green):	OK ready for operation
LEDs "I1"..."I4" (yellow):	Binarily coded command value call-ups
LED "I5" (yellow)	Slave mode
LED "I6" (yellow)	Command value valid
LED "I7" (yellow)	Not assigned

[] = assignment to the block diagrams on pages 7, 9 and 11

Block diagram

**VT-VPD-1-1X/V0/1-0-1 for A4VS...HS4
axial piston pump with AWX F004 D01
swivel angle sensor**

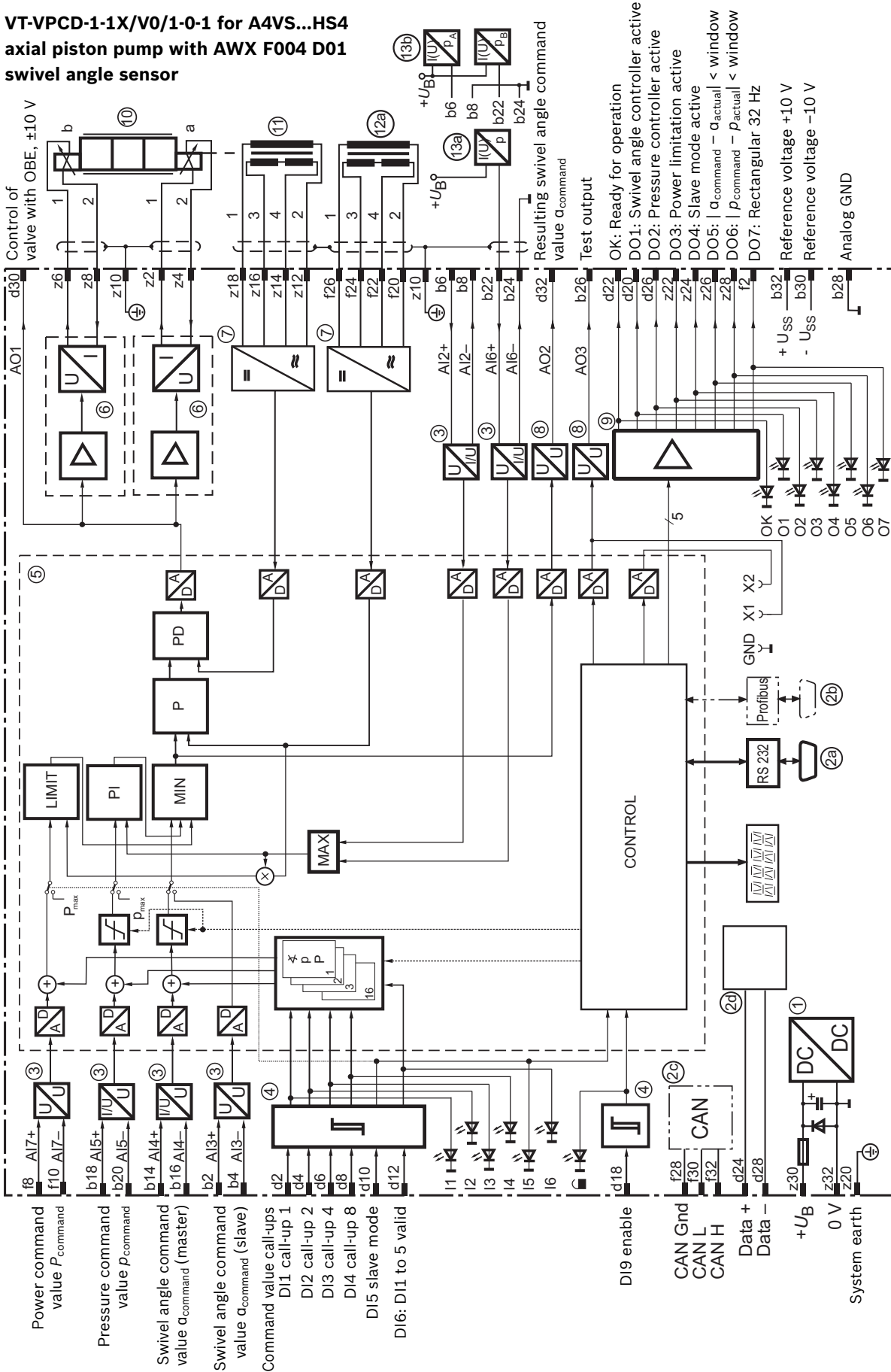

- 1** Power supply unit
- 2a** Serial interface
- 2b** PROFIBUS interface, optional
- 2c** CAN interface, optional
- 2d** Local bus
- 3** Voltage and/or current input
- 4** Level converter
- 5** Microcontroller
- 6** Flow-controlled output stage
- 7** Oscillator/demodulator
- 8** Voltage output
- 9** Output driver
- 10** Proportional valve
- 11** Position transducer of valve
- 12a** Swivel angle sensor of pump
- 13a** Pressure sensor current (open circuit)
- 13b** Pressure sensors current (closed circuit)

Pin assignment of the male multipoint connector

VT-VPCD-1-1X/V0/1-0-1 for A4VS...HS4 axial piston pump with AWX F004 D01 swivel angle sensor

Row d		
Pin	Short denomination	Description
2	DI1	Command value call-up 1, H active
4	DI2	Command value call-up 2, H active
6	DI3	Command value call-up 4, H active
8	DI4	Command value call-up 8, H active
10	DI5	Slave mode, H active
12	DI6	DI1 to DI5 valid, H active
14		n.c.
16		n.c.
18	DI9	Enable, H active
20	DO1	Swivel angle controller active, H active
22	OK	OK output, H active
24	Data +	Local bus
26	DO2	Pressure controller active, H active
28	Data -	Local bus
30	AO1	Control of valve with OBE, ± 10 V
32	AO2	Resulting swivel angle command value for master/slave operation

Row b		
Pin	Short denomination	Description
2	AI3+	Slave swivel angle command value (in case of slave operation)
4	AI3-	Slave swivel angle command value, reference
6	AI2+	Actual pressure value p_A , (I or U)
8	AI2-	Actual pressure value p_A , reference
10		n.c.
12		n.c.
14	AI4+	Swivel angle command value
16	AI4-	Swivel angle command value, reference
18	AI5+	Pressure command value
20	AI5-	Pressure command value, reference
22	AI6+	Actual pressure value p_B , (I or U)
24	AI6-	Actual pressure value p_B , reference
26	AO3	Test output (measuring socket X1)
28	AGND	Analog GND
30	REF-	Reference voltage -10 V
32	REF+	Reference voltage +10 V

Row z		
Pin	Short denomination	Description
2	MA+	Solenoid A +
4	MA-	Solenoid A -
6	MB+	Solenoid B +
8	MB-	Solenoid B -
10	Shield	Shield
12	L10-	Position transducer of valve, feed -, pin 2
14	L11-	Position transducer of valve, actual value -, pin 4
16	L11+	Position transducer of valve, actual value +, pin 3
18	L10+	Position transducer of valve, feed +, pin 1
20	System earth	System earth
22	DO3	Power limitation active, H active
24	DO4	Slave mode active, H active
26	DO5	$ \alpha_{\text{command}} - \alpha_{\text{actual}} < \text{window}$, H active
28	DO6	$ p_{\text{command}} - p_{\text{actual}} < \text{window}$, H active
30	UB	Supply voltage $+U_B$
32	LO	Supply voltage 0 V

Row f		
Pin	Short denomination	Description
2	DO7	Rectangular 32 Hz
4		n.c.
6		n.c.
8	AI7+	Power command value
10	AI7-	Power command value, reference
12		n.c.
14		n.c.
16		n.c.
18		n.c.
20	L20-	Swivel angle sensor of pump, feed -, pin 2
22	L21-	Swivel angle sensor of pump, actual value -, pin 4
24	L21+	Swivel angle sensor of pump, actual value +, pin 3
26	L20+	Swivel angle sensor of pump, feed +, pin 1
28	CAN Gnd	CAN bus reference
30	CAN L	CAN bus input/output
32	CAN H	CAN bus input/output

Block diagram

VT-VP-CD-1-1X/V0/1-0-1 for A2V...E04 axial piston pump (housing pump) with MCP-40/4742 swivel angle sensor

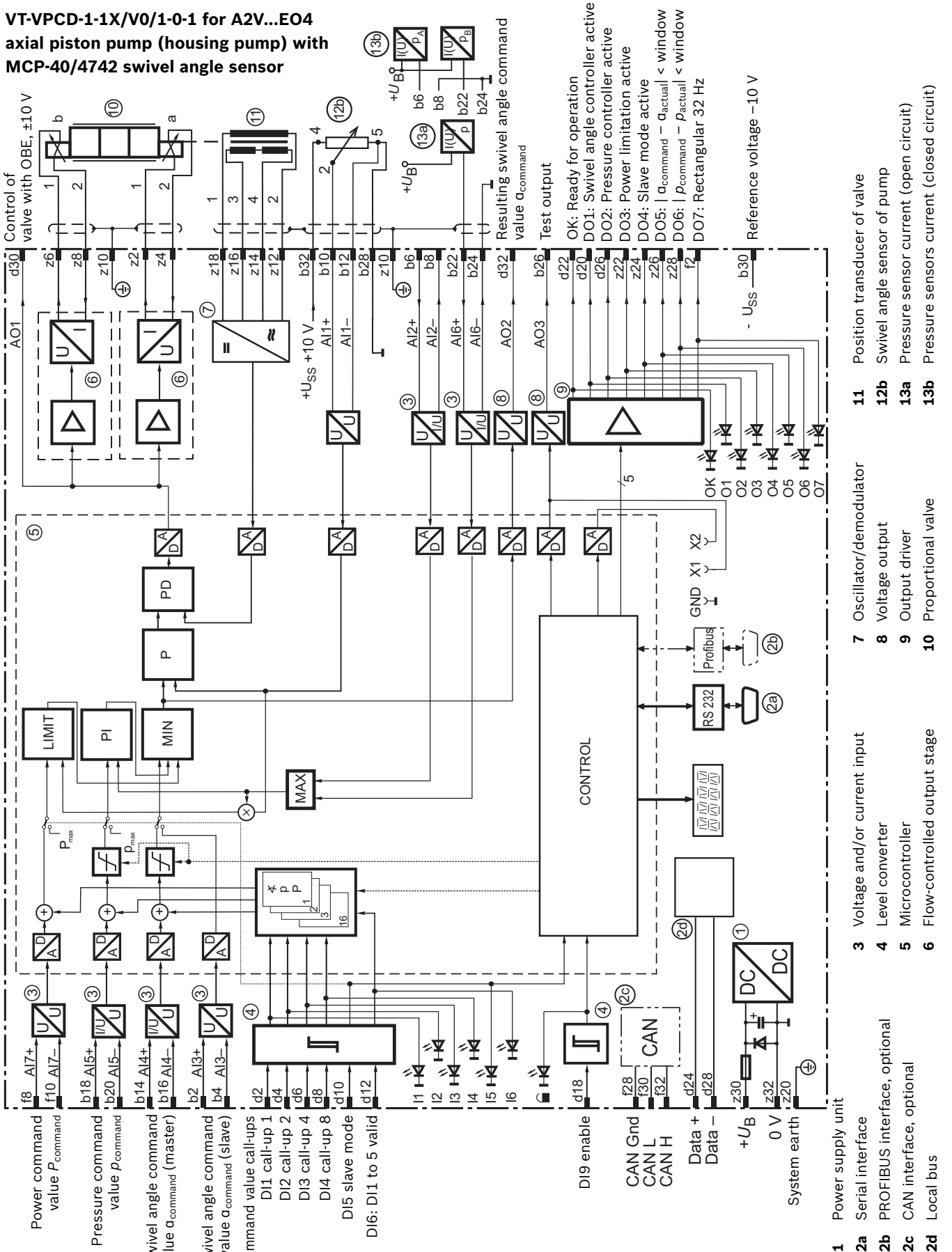

Pin assignment of the male multipoint connector

VT-VPD-1-1X/V0/1-0-1 for A2V...EO4 axial piston pump (housing pump) with MCP-40/4742 swivel angle sensor

Row d		
Pin	Short denomination	Description
2	DI1	Command value call-up 1, H active
4	DI2	Command value call-up 2, H active
6	DI3	Command value call-up 4, H active
8	DI4	Command value call-up 8, H active
10	DI5	Slave mode, H active
12	DI6	DI1 to DI5 valid, H active
14		n.c.
16		n.c.
18	DI9	Enable, H active
20	DO1	Swivel angle controller active, H active
22	OK	OK output, H active
24	Data +	Local bus
26	DO2	Pressure controller active, H active
28	Data -	Local bus
30	AO1	Control of valve with OBE, ± 10 V
32	AO2	Resulting swivel angle command value for master/slave operation

Row b		
Pin	Short denomination	Description
2	AI3+	Slave swivel angle command value (in case of slave operation)
4	AI3-	Slave swivel angle command value, reference
6	AI2+	Actual pressure value p_A , (I or U)
8	AI2-	Actual pressure value p_A , reference
10	AI1+	Swivel angle sensor of pump, pin 2
12	AI1-	Swivel angle sensor of pump, pin 5
14	AI4+	Swivel angle command value
16	AI4-	Swivel angle command value, reference
18	AI5+	Pressure command value
20	AI5-	Pressure command value, reference
22	AI6+	Actual pressure value p_B , (I or U)
24	AI6-	Actual pressure value p_B , reference
26	AO3	Test output (measuring socket X1)
28	AGND	Analog GND and swivel angle sensor of pump, pin 5
30	REF-	Reference voltage -10 V
32	REF+	Reference voltage +10 V and swivel angle sensor of pump, pin 4

Row z		
Pin	Short denomination	Description
2	MA+	Solenoid A +
4	MA-	Solenoid A -
6	MB+	Solenoid B +
8	MB-	Solenoid B -
10	Shield	Shield
12	L10-	Position transducer of valve, feed -, pin 2
14	L11-	Position transducer of valve, actual value -, pin 4
16	L11+	Position transducer of valve, actual value +, pin 3
18	L10+	Position transducer of valve, feed +, pin 1
20	System earth	System earth
22	DO3	Power limitation active, H active
24	DO4	Slave mode active, H active
26	DO5	$ \alpha_{\text{command}} - \alpha_{\text{actual}} < \text{window}$, H active
28	DO6	$ p_{\text{command}} - p_{\text{actual}} < \text{window}$, H active
30	UB	Supply voltage $+U_B$
32	LO	Supply voltage 0 V

Row f		
Pin	Short denomination	Description
2	DO7	Rectangular 32 Hz
4		n.c.
6		n.c.
8	AI7+	Command value power
10	AI7-	Command value power, reference
12		n.c.
14		n.c.
16		n.c.
18		n.c.
20		n.c.
22		n.c.
24		n.c.
26		n.c.
28	CAN Gnd	CAN bus reference
30	CAN L	CAN bus input/output
32	CAN H	CAN bus input/output

Pin assignment of the male multipoint connector

VT-VPCD-1-1X/V100/1-0-1 for A2V...EO4 axial piston pump (installation pump) with DK 100 swivel angle sensor

Row d		
Pin	Short denomination	Description
2	DI1	Command value call-up 1, H active
4	DI2	Command value call-up 2, H active
6	DI3	Command value call-up 4, H active
8	DI4	Command value call-up 8, H active
10	DI5	Slave mode, H active
12	DI6	DI1 to DI5 valid, H active
14		n.c.
16		n.c.
18	DI9	Enable, H active
20	DO1	Swivel angle controller active, H active
22	OK	OK output, H active
24	Data +	Local bus
26	DO2	Pressure controller active, H active
28	Data -	Local bus
30	AO1	Control of valve with OBE, ± 10 V
32	AO2	Resulting swivel angle command value for master/slave operation

Row b		
Pin	Short denomination	Description
2	AI3+	Slave swivel angle command value (in case of slave operation)
4	AI3-	Slave swivel angle command value, reference
6		n.c.
8		n.c.
10		n.c.
12		n.c.
14	AI4+	Swivel angle command value
16	AI4-	Swivel angle command value, reference
18	AI5+	Pressure command value
20	AI5-	Pressure command value, reference
22	AI6+	Actual pressure value p_B , (I or U)
24	AI6-	Actual pressure value p_B , reference
26	AO3	Test output (measuring socket X1)
28	AGND	Analog GND
30	REF-	Reference voltage -10 V
32	REF+	Reference voltage +10 V

Row z		
Pin	Short denomination	Description
2	MA+	Solenoid A +
4	MA-	Solenoid A -
6	MB+	Solenoid B +
8	MB-	Solenoid B -
10	Shield	Shield
12	L10-	Position transducer of valve, feed -, pin 2
14	L11-	Position transducer of valve, actual value -, pin 4
16	L11+	Position transducer of valve, actual value +, pin 3
18	L10+	Position transducer of valve, feed +, pin 1
20	System earth	System earth
22	DO3	Power limitation active, H active
24	DO4	Slave mode active, H active
26	DO5	$ \alpha_{\text{command}} - \alpha_{\text{actual}} < \text{window}$, H active
28	DO6	$ p_{\text{command}} - p_{\text{actual}} < \text{window}$, H active
30	UB	Supply voltage $+U_B$
32	LO	Supply voltage 0 V

Row f		
Pin	Short denomination	Description
2	DO7	Rectangular 32 Hz
4		n.c.
6		n.c.
8	AI7+	Command value power
10	AI7-	Command value power, reference
12		n.c.
14		n.c.
16		n.c.
18		n.c.
20	L20-	Swivel angle sensor of pump, feed -, pin 4
22	L21-	Swivel angle sensor of pump, actual value -, pin 3
24	L21+	Swivel angle sensor of pump, actual value +, pin 2
26	L20+	Swivel angle sensor of pump, feed +, pin 1
28		n.c.
30		n.c.
32		n.c.

Pin assignment of the D-Sub sockets on the front plate

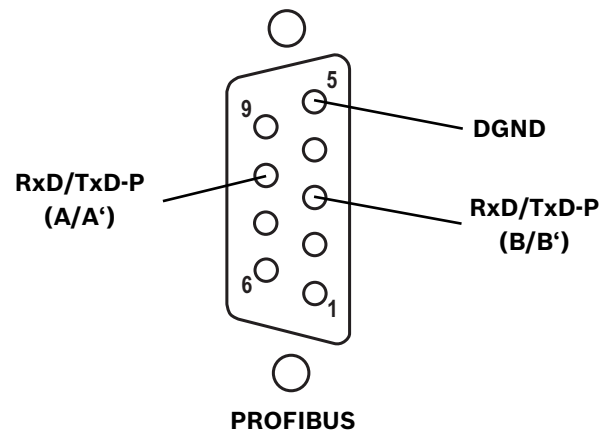
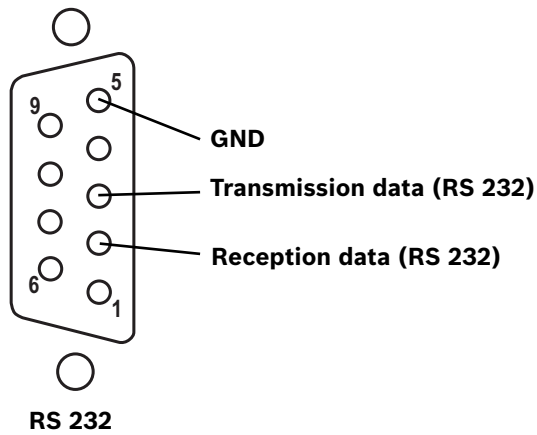

Dimensions (dimensions in mm)

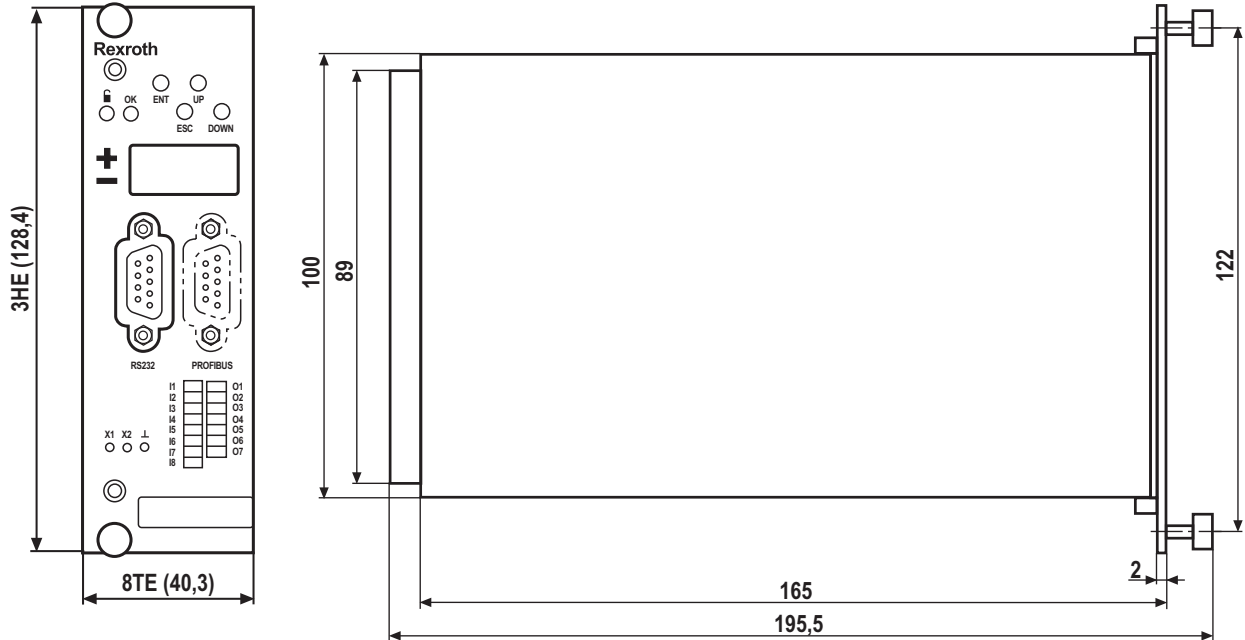

Technical data (for applications outside these parameters, please consult us!)

Valve 4WRE6-2X/822 for HS4 control		
Current consumption per solenoid	I_{\max}	2.5 A
Control current with constant swivel angle	I_a	Solenoid a: 450 mA
	I_b	Solenoid b: 700 mA
Solenoid coil resistance:		
Cold value at 20 °C	R	2.7 Ω
Max. hot value	R	4.05 Ω
Electrical connection		Plug-in connection according to DIN EN 175301-803
Protection class according to EN 60529		IP 65
Position transducer to the valve 4WRE6-2X/822		
Carrier frequency	f	5 kHz
Coil resistance (at 20 °C):		
Between ports 1 and 2	R	150 \pm 11 Ω
Between ports 3 and 4	R	50 \pm 3.5 Ω
Electrical connection		Plug-in connection according to DIN 43650-BFZ-Pg9
Protection class of the plug-in connection according to EN 60529		IP 65
Swivel angle sensor type AWX F004 D01		
Carrier frequency	f	5 kHz
Coil resistance (at 20 °C):		
Between ports 1 and 2	R	110 Ω
Between ports 3 and 4	R	560 Ω
Electrical connection		Plug-in connection according to DIN 43650-BFZ-Pg9
Protection class of the plug-in connection according to EN 60529		IP 65
Closed-loop control quality of the HS4 control		
Hysteresis	%	\leq 0.2
Repetition accuracy	%	\leq 0.2
Linearity deviation of the swivel angle	%	\leq 1.0
Linearity deviation of the pressure	%	\leq 1.5 of the maximum measuring pressure of the pressure transducer

Technical data (For applications outside these parameters, please consult us.)

VT-VPCD-1-1X/.../1-0-1 control electronics		
Operating voltage	U_B	24 VDC
Operating range		
Upper limit value	$U_B(t)_{\max}$	30 V
Lower limit value	$U_B(t)_{\min}$	21 V
Current consumption	I_{\max}	3.5 A
Oscillator frequency (valve position transducer, swivel angle)	f	Approx. 5 kHz at 10 V _{SS}
Digital inputs	Signal	log 0 = 0 to 5 V log 1 = 16 V to U_B
Digital outputs	Signal	log 0 = 0 to 5 V log 1 = $U_B - 3$ V $I_{\max} = 30$ mA, short-circuit-proof
Analog inputs AI1...AI7 can be configured as voltage input		
AI3, AI4	U	± 10 V
AI1, AI2, AI5, AI6, AI7	U	0 to 10 V
Input resistance	R_e	100 k Ω
Resolution	U	5 mV for range ± 10 V, 2.5 mV for range 0 to 10 V
Non-linearity	U	< 10 mV
Analog inputs AI2, AI4, AI5 and AI6 can be configured as current inputs		
Range	I	4 to 20 mA
Input resistance	R_e	100 Ω (voltage drop at actual pressure value input with 4 mA approx. 1.7 V, with 20 mA approx. 3.5 V)
Leakage current		0.15 % (with 500 Ω between pin AI x - and 0 V)
Resolution	I	5 μ A [12 bit]
Analog outputs AO1, AO2 and AO3		
Output voltage	U	± 10 V
Load	$R_{L\min}$	1 k Ω
Resolution	U	10 mV (11 bit)
Residual ripple	U	± 25 mV (without noise)
Reference voltage		
Voltage	U	± 10 V
Current	I_{\max}	30 mA
Residual ripple	U	< 20 mV
Scan time	T	2 ms
Serial interface		RS 232 (front plate), D-Sub socket 9-pole
Type of connection		64-pole male multipoint connector, DIN 41612, design G
Local bus, distance to the furthest device	l	Max. 280 m line length
Card dimensions		Euro-card 100 x 160 mm, DIN 41494
Front plate dimensions:		
Height		3 HE (128.4 mm)
Width soldering side		1 TE (5.08 mm)
Width component side		7 TE (35.56 mm)
Admissible ambient temperature range	ϑ	0 to 50 °C
Storage temperature range	ϑ	-20 to +70 °C
Weight	m	0.2 kg

Notice:

For information on the **environment simulation testing** for the areas EMC (electromagnetic compatibility), climate and mechanical load, see data sheet 30028-U.

Project planning/maintenance instructions/additional information

Product documentation for the VT-VPCD

30028	Technical data sheet (this document)
30028-B	Installation and operating instructions
30028-01-B	Commissioning and operating instructions
30028-U	Environmental compatibility statement
30028-01-Z	Commissioning instructions, PROFIBUS interface
30028-02-Z	Commissioning instructions, CANopen interface
30028-03-Z	Commissioning instructions, DeviceNet interface

- ▶ The control electronics may only be unplugged and plugged when de-energized.
- ▶ Only carry out measurements at the card using instruments with $R_i > 100 \text{ k}\Omega$.
- ▶ For switching analog command values and digital call-ups, use relays with gold-plated contacts (low voltages, low currents).
- ▶ Always shield command and actual value cables; connect shielding to system earth on the card-side, open at one side.
- ▶ Recommendation: Up to a length of 50 m, use the line type LiYCY 1.5 mm² for solenoid line, for position transducer line use cable type LiYCY 0.5 mm², shielded. For greater lengths, please contact us.
- ▶ The distance to aerial lines or radios must be at least 1 m!
- ▶ Do not lay solenoid conductors and signal lines near power lines.
- ▶ Commissioning and programming of the control electronics are described in detail in the operating instructions 30028-B.
- ▶ For perfect control results, the quality of the sensors is important.

Bosch Rexroth AG
 Hydraulics
 Zum Eisengießer 1
 97816 Lohr am Main, Germany
 Phone +49 (0) 93 52/18-0
 documentation@boschrexroth.de
 www.boschrexroth.de

© This document, as well as the data, specifications and other information set forth in it, are the exclusive property of Bosch Rexroth AG. It may not be reproduced or given to third parties without its consent.
 The data specified above only serve to describe the product. No statements concerning a certain condition or suitability for a certain application can be derived from our information. The information given does not release the user from the obligation of own judgment and verification. It must be remembered that our products are subject to a natural process of wear and aging.