

VT-VPCD

Digital closed-loop control electronics for axial piston pumps
A4VS... with HS4 control and A2V... with EO4 control

Operating instructions
RE 30028-B/09.13

Replaces: 10.12
English

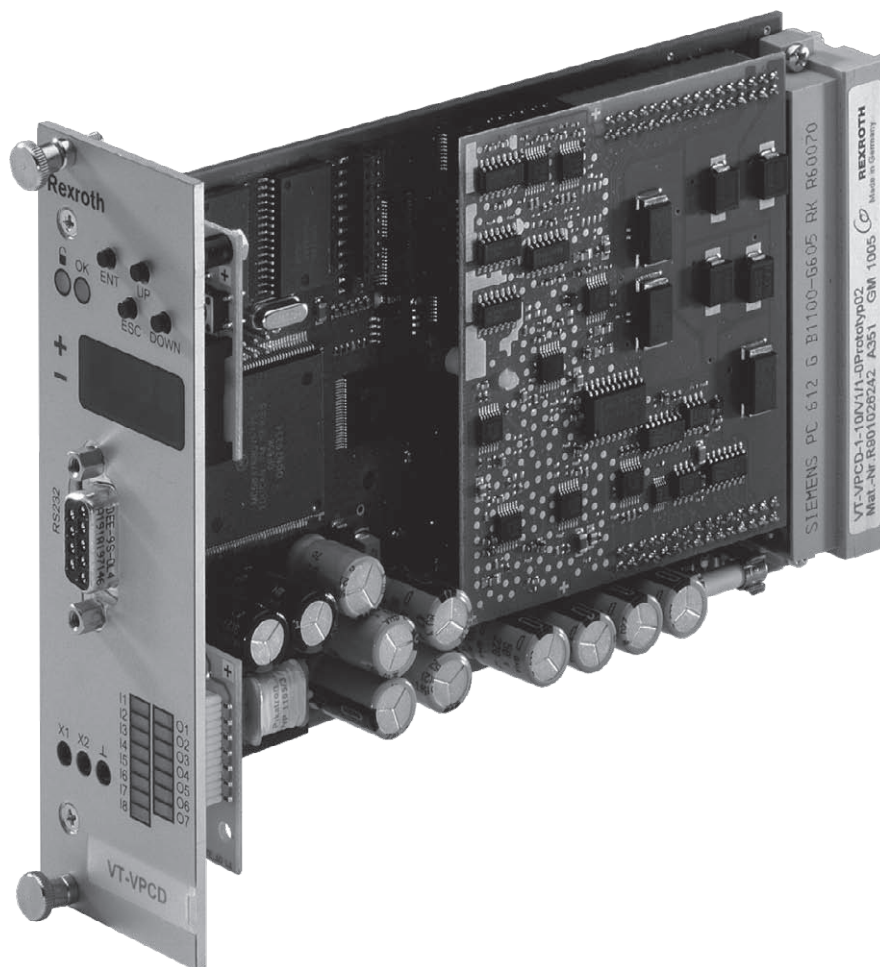

The data specified only serve to describe the product. No statements concerning a certain condition or suitability for a certain application can be derived from our information. The information given does not release the user from the obligation of own judgment and verification. It must be remembered that our products are subject to a natural process of wear and aging.

© This document, as well as the data, specifications and other information set forth in it, are the exclusive property of Bosch Rexroth. It may not be reproduced or given to third parties without its consent.

An example configuration is shown on the title page. The delivered product may, therefore, differ from the product which is pictured.

The original operating instructions were created in the German language.

Inhalt

1	About this documentation	5
1.1	Validity of the documentation	5
1.2	Required and supplementary documentation	5
1.3	Representation of information	6
1.3.1	Safety notes	6
1.3.2	Symbols	7
1.3.3	Terms used	7
1.3.4	Abbreviations	7
2	Safety instructions	8
2.1	About this chapter	8
2.2	Intended use	8
2.3	Improper use	8
2.4	Personnel qualifications	8
2.5	General safety instructions	9
2.6	Product-specific safety instructions	10
3	General notes on damage to material and the product	12
4	Scope of delivery	13
5	About this product	14
5.1	Performance description	14
5.2	Product description	14
5.2.1	Circuit variants	15
5.2.2	Block circuit diagrams	20
5.2.3	Display and operating elements and test sockets	23
5.2.4	Pinout of the edge connector	25
5.3	Identification of the product	28
6	Transport and storage	28
6.1	Storing the VT-VPCD	28
7	Installation	29
7.1	Unpacking	29
7.2	Required tools	29
7.3	Installation conditions	30
7.4	Recommended accessories	30
7.5	Installing the VT-VPCD	30
7.5.1	Installing the local bus	32
7.5.2	Connecting solenoids and sensorics	32
8	Commissioning	37
8.1	Initial commissioning	37
8.1.1	Establishing operational readiness	37
8.1.2	Installing software BODAC	37
9	Operation	39
9.1	Indicator/operating elements and ports of the control electronics	39
9.1.1	Menu tree for setup and parameters	39
9.2	Operating the control electronics VT-VPCD	46
9.3	Performing diagnostics	50

9.3.1	Diagnostic options on control electronics VT-VPCD	50
9.3.2	Diagnostics options using BODAC with WinView	50
10	Maintenance and repair	51
10.1	Cleaning and care	51
10.2	Maintenance	51
10.3	Repair	51
11	Removal and replacement	52
11.1	Preparing the removal	52
11.2	Removal	52
11.3	Preparing components for storage/further use	52
12	Disposal	52
12.1	Environmental protection	52
13	Extension and conversion	52
14	Troubleshooting	53
14.1	How to proceed for troubleshooting	53
14.2	Error messages	53
14.3	Changing the fuse	54
15	Technical data	55
16	Annex	56
16.1	Address directory	56
16.1.1	Contact for repairs	56
16.1.2	Contact for support	56
17	Alphabetical index	57

1 About this documentation

1.1 Validity of the documentation

This documentation is valid for the following products:

- VT-VPCD-1-1X/V0/1-0-1, material number R901044346
- VT-VPCD-1-1X/V0/1-C-1, material number R901102344
- VT-VPCD-1-1X/V0/1-D-1, material number R901102347
- VT-VPCD-1-1X/V0/1-P-1, material number R901089559
- VT-VPCD-1-1X/V100/1-0-1, material number R901078493

This documentation is intended for fitters, operators, service technicians and plant operators.

This documentation contains important information on the safe and appropriate installation, transport, commissioning, maintenance, operation, removal and simple troubleshooting of the product.

- ▶ Read this documentation thoroughly, especially Chapter 2 “Safety instructions” and Chapter 3 “General notes on damage to property and damage to the product” before working with the digital control electronics VT-VPCD.

1.2 Required and supplementary documentation



- ▶ Only commission the product when you have the documents identified with the book symbol  at hand and have understood and observed them. You can find operating instructions and data sheets on our website www.boschrexroth.com/mediadirectory.

Table 1: Required and supplementary documentation

Title	Document number	Document type
 Order confirmation		
 VT-VPCD – digital control electronics for A4VS... axial piston units with HS4 control and A2V... with EO control	RE 30028	Data sheet
VT-VPCD – digital closed-loop control electronics for axial piston pumps A4VS... with HS4 control and A2V... with EO4 control	RE 30028-01-Z	Commissioning instructions for Profibus
VT-VPCD - digital closed-loop control electronics for axial piston pumps A4VS... with HS4 control and A2V... with EO4 control	RE 30028-02-Z	Commissioning instructions for CANopen interface
VT-VPCD – digital closed-loop control electronics for axial piston pumps A4VS... with HS4 control and A2V... with EO4 control	RE 30028-03-Z	Commissioning instructions for DeviceNet interface
Online help BODAC	RE 30028-01-B	Online help
Declaration on environmental compatibility in the fields of EMC, climate and mechanical stress	RE 30028-U	Declaration on environmental compatibility
Pressure transducer for hydraulic applications, HM 20	RE 30272	Data sheet

1.3 Representation of information

In order to allow you to work directly and safely with your product, standardized safety notes, symbols, terms and abbreviations are used. For a better understanding, these are explained in the following sections.

1.3.1 Safety notes



This documentation contains safety notes in Chapter 2.6 “Product-specific safety instructions“ and Chapter 3 “General notes on damage to material and the product“ as well as before a sequence of activities or instructions for action, which involve the risk of personal injury or damage to equipment. The measures described for averting the hazard must be observed.

Safety notes are structured as follows:

 SIGNAL WORD
<p>Type and source of hazard! Consequences in the case of non-observance</p> <ul style="list-style-type: none"> ▶ Measures to avert the hazard ▶ <List>

- **Warning symbol:** draws attention to a hazard
- **Signal word:** identifies the degree of hazard
- **Type and source of hazard:** identifies the type or source of the hazard
- **Consequences:** describes the consequences in the case of non-observance
- **Precautions:** states, how the hazard can be avoided

Table 2: Hazard classes according to ANSI Z535.6-2006

Warning sign, signal word	Meaning
 DANGER	Indicates a hazardous situation which, if not avoided, will certainly result in death or serious injury.
 WARNING	Indicates a hazardous situation which, if not avoided, could result in death or serious injury.
 CAUTION	Indicates a hazardous situation which, if not avoided, could result in minor or moderate injury.
NOTICE	Damage to property: The product or the environment can be damaged.

1.3.2 Symbols

The following symbols refer to notes, which are not relevant to safety, but increase the legibility of the documentation.

Table 3: Meaning of symbols

Symbol	Meaning
	If this information is disregarded, the product cannot be used or operated in an optimum manner.
▶	Individual, independent step of action
1.	Numbered instructions for action:
2.	The numbers indicate that the activities are to be carried out consecutively.
3.	

1.3.3 Terms used

The following terms are used in this documentation:

Table 4: Terms

Term	Meaning
LVDT	Linear Variable Differential Transformer (position transducer)
U_B	Operating voltage
BODAC	Bosch Rexroth Operator Interface for Digital Axis Controllers

1.3.4 Abbreviations

The following abbreviations are used in this documentation:

Table 5: Abbreviations

Abbreviation	Meaning
AI	Analog Input
AO	Analog Output
DI	Digital Input
DO	Digital Output
LSB	Least Significant Bit
MSB	Most Significant Bit
n.c.	not connected
SWA	Swivel Angle

2 Safety instructions

2.1 About this chapter

The product has been manufactured according to the generally accepted rules of current technology. There is, however, still a risk of personal injury or damage to equipment if you do not observe this Chapter and the safety instructions contained in this documentation.

- ▶ Read these instructions completely and thoroughly before working with the product.
- ▶ Keep this documentation in a location where it is accessible to all users at all times.
- ▶ Always pass the product together with the required documentation to third parties.

2.2 Intended use

The product is an electrical component.

You may use the product as follows:

- for realizing all the required electrical functions for the HS4 or EO4 control with electrohydraulic swivel angle and pressure control as well as for the power limitation of variable displacement axial piston pumps.

The product is intended exclusively for professional use and not for private usage. Operation according to the intended use also implies that you have read and understood this documentation completely, especially Chapter 2 “Safety instructions“.

2.3 Improper use

Any use other than described in the section “Intended use” is considered as improper and is therefore not permitted.

For damage resulting from improper use, Bosch Rexroth AG will not bear liability.

The risks arising from improper use lie exclusively with the user.

The following, foreseeable misuse is also not in accordance with the intended use:

- Use of the control electronics for activating components or devices other than the above-mentioned pump controls;
- if you operate the control electronics beyond the given performance limits and operating conditions, especially the prescribed ambient conditions.

2.4 Personnel qualifications

The activities described in this documentation require basic knowledge of electrics and hydraulics as well as knowledge of the associated technical terms. To ensure safe usage, these activities may therefore only be carried out by qualified personnel or under the direction and supervision of qualified personnel.

Qualified personnel are those who, due to their professional training, knowledge and experience as well as their knowledge of relevant regulations, can assess work assigned

to them, recognize potential hazards and institute appropriate safety measures. Qualified personnel must observe relevant specialist rules and have the required expertise.

With regard to hydraulic products, specialist knowledge means, for example:

- Ability to read and completely understand hydraulic circuit diagrams,
- complete understanding in particular of interrelationships with regard to safety equipment and
- knowledge of the function and structure of hydraulic components.



Bosch Rexroth offers qualifying training courses in specific fields. You can find an overview of training contents on the Internet at:

<http://www.boschrexroth.de/didactic>

2.5 General safety instructions

- Observe valid regulations for accident prevention and environmental protection.
- Observe the safety regulations and rules of the country where the product is used/operated.
- Use Rexroth products only in technically perfect condition.
- Observe all notes given on the product.
- Persons who install, commission, operate, demount or maintain Rexroth products must not consume any alcohol, drugs or pharmaceuticals that may affect their ability to respond.
- Only use accessory and spare parts approved by the manufacturer in order to rule out personnel hazards arising from unsuitable spare parts.
- Adhere to the technical data and ambient conditions provided in the product documentation.
- If unsuitable products are installed or used in safety-relevant applications, unintended operational states can occur in these applications, which can cause personal injury and damage to property. Therefore, use the product only in safety-relevant applications such as in explosion protection areas or in safety-related parts of a control (functional safety), if this use is expressly specified and permitted in the documentation.
- You may commission the product only when it has been established that the final product (for example, a machine or system), in which the Rexroth products are installed, complies with national regulations, safety regulations and standards relevant for the application.

2.6 Product-specific safety instructions

WARNING

Hazardous movement!

Risk of injury due to incorrect activation of the pump control by the control electronics and resulting unforeseeable machine movements.

- ▶ Only operate the control electronics in conjunction with the pump control specified in the type code.
- ▶ If persons have to enter the hazard zone while the control is active, provide superordinate monitoring functions or measures for personal safety at system level. The plant manufacturer/user must rate and dimension these measures on the basis of a risk and failure analysis according to the specific situation on site. The safety regulations valid for the system must be taken into account for this.

The control electronics emits interference to other electronics within the permitted limit values. This can cause malfunction in the control process.

- ▶ Only use electronics below the EMC limit values or provide appropriate shielding.

The control electronics VT-VPCD responds to electromagnetic interference from non-shielded, improperly installed or wrongly connected cables. If the limit values given in the data sheet are exceeded, malfunction or uncontrolled movements are possible.

- ▶ Adhere to the limit values specified in the data sheet, use only electronics below the EMC limit values or provide proper shielding.

Electrostatic processes, an inadequate grounding concept or missing equipotential bonding can lead to damage to the electronics and hence cause malfunction or uncontrolled movements of the machine.

- ▶ Ensure proper grounding and provide equipotential bonding.

Using the product outside the given IP protection class can result in short-circuit and malfunction and can therefore cause uncontrolled machine movements.

- ▶ Only use the product within the IP protection class and under ambient conditions as given in the data sheet.

The control electronics VT-VPCD itself does not include safety functions for personal safety and is therefore no safety-relevant component. The control electronics merely serves to generate electrical functions of the pump controls.

- ▶ Provide safety functions for personal safety separately.
- ▶ Avoid contact with salt-containing environments and adhere to the ambient conditions specified in the data sheet.

High pressure!

Risk of injury!

- ▶ Depressurize the relevant system section before carrying out any work on the control electronics.

WARNING

High electric voltage due to incorrect connection!

Danger to life, risk of injury through electric shock.

- ▶ Only connect devices, electrical components and lines which feature protective extra low voltage (PELV) to connections or terminals having voltages from 0 to 50 Volt.
- ▶ Only connect voltages and power circuits that feature safe isolation from dangerous voltages. Safe electrical isolation can be achieved for example with isolating transformers, safe optocouplers or mains-free battery operation.

High voltage!

Risk of injury.

- ▶ Wire or plug in the control electronics VT-VPCD only when it is disconnected from the power supply.

Lightning!

Risk of uncontrolled machine movements.

- ▶ An inadequate grounding concept or missing equipotential bonding can lead to damage to the electronics. Ensure equipotential bonding for the device.

Failures and defects in the control current circuits or the energy supply!

Risk of uncontrolled machine movements.

- ▶ Ensure safety in accordance with EN ISO 13849 or IEC 62061.

CAUTION

Hot surfaces!

Risk of burning. System parts can heat up during operation.

- ▶ Let system parts cool down before touching them or wear protective gloves.

Fault currents and short-circuits!

Reduced safety and malfunction.

- ▶ The environment must be free from conductive contamination (acids, lyes, corrosive agents, salts, metal vapors, etc.) and the device must not be exposed to them. Generally, rule out deposits according to protection class IP 65.

3 General notes on damage to material and the product

The warranty is valid exclusively for the configuration delivered.

- Warranty claims will be rejected in the case of improper installation, commissioning and operation as well as in the case of use not in accordance with the intended purpose and/or improper handling.

NOTICE

High voltage!

Possible damage to the control electronics.

- ▶ Wire the control electronics only when it is disconnected from the power supply.

Overheating!

Possible damage to the control electronics.

- ▶ Adhere to the ambient conditions according to the data sheet.
- ▶ Do not use free-wheeling diodes in the solenoid cables.
- ▶ Ensure sufficient ventilation of air.

Overloading!

Risk of overloading and damage to supply cables in the case of insufficient dimensioning and/or operation with several electrical devices.

- ▶ Provide current limitation by overload protection.
- ▶ Select an appropriate rating of power supply unit and cables.

Short-circuit!

Risk of overloading and damage to the supply cable in the case of a defect of electrical equipment.

- ▶ Provide current limitation by means of overload protection.

Electrostatic discharge!

Risk of damage to components of the control electronics.

- ▶ Provide equipotential bonding to discharge static voltage from your body.
- ▶ Work in a safe environment.
- ▶ Do not use devices that generate or have static discharge in the working environment.
- ▶ Do not carry out any work on the control electronics in environments that could generate static charges.
- ▶ Handle the control electronics with care. Do not touch exposed connection pins and sensitive components of the electronics.
- ▶ Transport and store the control electronics carefully in the original packaging provided for this purpose.

Wrong cables! Voltage loss, scorching of cable!

Risk of damage to the product.

- ▶ For solenoid cables up to 50 m long, use cable type LiYCY 1.5 mm², for position transducer cables, cable type LiYCY 0.5 mm² shielded. For greater lengths, please consult us.

NOTICE

Cables lying around!

Risk of stumbling!

- ▶ Install cables and lines so that they cannot be damaged and nobody can stumble over them.

4 Scope of delivery

The scope of delivery includes the digital control electronics VT-VPCD.

Accessories such as interface cables and card holders are not included in the scope of supply, but can be ordered separately. See Chapter 7.4 “Recommended accessories“ on page 30.

5 About this product

5.1 Performance description

The closed-loop control electronics VT-VPCD is part of a control system for the electrohydraulic control of swivel angle and pressure and power limitation of axial piston pumps of type A4VS... with HS4 control as well as axial piston pumps of type A2V... with EO4 control, each fitted with a proportional valve and swivel angle and position transducers for sensing the swivel angle and the valve spool travel. The control electronics VT-VPCD provides all electrical functions required for the control types HS4 and EO4. The control electronics VT-VPCD can be configured using the software BODAC.

5.2 Product description

The figures given in brackets refer to the block circuit diagrams in Chapter 5.2.2 “Block circuit diagrams“ from page 20 on.

The operating principle of the complete system is explained in data sheet RE 30028. The digital control electronics VT-VPCD consists of a swivel angle controller, a pressure controller and a valve controller as well as of a power limiter. The position of the pump’s swashplate is sensed by an inductive swivel angle transducer, the actual pressure value is sensed by a pressure transducer. Both actual values are fed to the control electronics and linked to each other by software. The actual power value is formed by the product of actual pressure value and actual swivel angle value. The controller software ensures with the help of a minimum value comparator that only the controller is active, which is assigned to the relevant working point. The control electronics is designed as double-sided printed-circuit board in Euro-card format 100 x 160 mm. It comprises a switched-mode power supply unit [1], which generates all the internally required voltages.

The central unit is a micro-controller, which controls the entire sequence and realizes the functions of the controller. Configuration data, command values and parameters are saved in a non-volatile FLASH.

Four binary-coded digital inputs are used for calling up parameter sets (command values) from the memory, in which a maximum of 16 sets can be saved. A call-up activates a command value for the swivel angle, pressure and power limitation as well as ramp times for swivel angle and pressure.

Further control inputs assume the following functions:

“Command valid“: Enable of the parameter set addressed by the current call-up (H-active)

“Enable“: Activation of control (H-active)

Remark: H-active = High-active Level

L-active = Low-active Level

L/H edge = Low/High edge

The analog command values for swivel angle, pressure and maximum power are provided via differential inputs AI7, AI5 and AI4 [3]. With a positive swivel angle command value, the pump swivels “to the left” (= direction of flow P -> B). The digital call-up command values are added to the analog command values, and the sum of both are fed via the relevant ramp generator to the input of the controller.

The output signal of the controller activates the output stage [6] in dependence on command/actual differences.

The position of the valve spool [11], the swivel angle of the variable displacement pump [12a, 12b or 12c] and the system pressure [13] are measured and fed via evaluation electronics [7] to the control loop.

5.2.1 Circuit variants

The axial piston pump A4VS...HS4 can be operated within various circuit variants. Adjustments are therefore necessary on the axial piston pump for each variant.

The following circuit variants are possible:

Hydraulic circuit variants

- Open circuit
- Closed circuit

Pump combinations (master/slave)

- Circuit with pressure sensorics - current
- Circuit with pressure sensorics - voltage

Open circuit When the axial piston pump A4VSO...HS4 is operated in the open circuit, a valve connection block is installed between the axial piston pump A4VSO.. and proportional valve 4WRE6-2X/822. The variant of the valve connection block depends on the pump's direction of rotation.

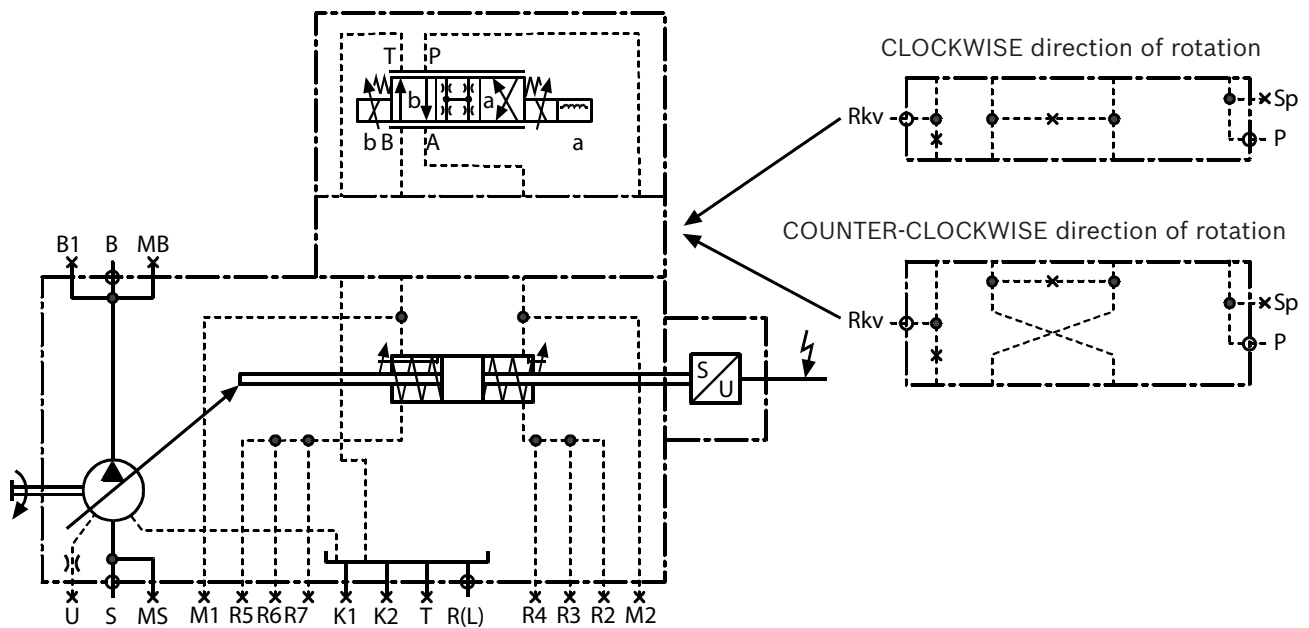

Fig. 1: Pump control in the open circuit with connection of the swivel angle transducer

Closed circuit When the axial piston pump A4VSG...HS4 is operated in the closed circuit, a valve connection block is installed between the axial piston pump A4VSG.. and proportional valve 4WRE6-2X/822. The variant of this valve connection block also depends on the pump's direction of rotation.

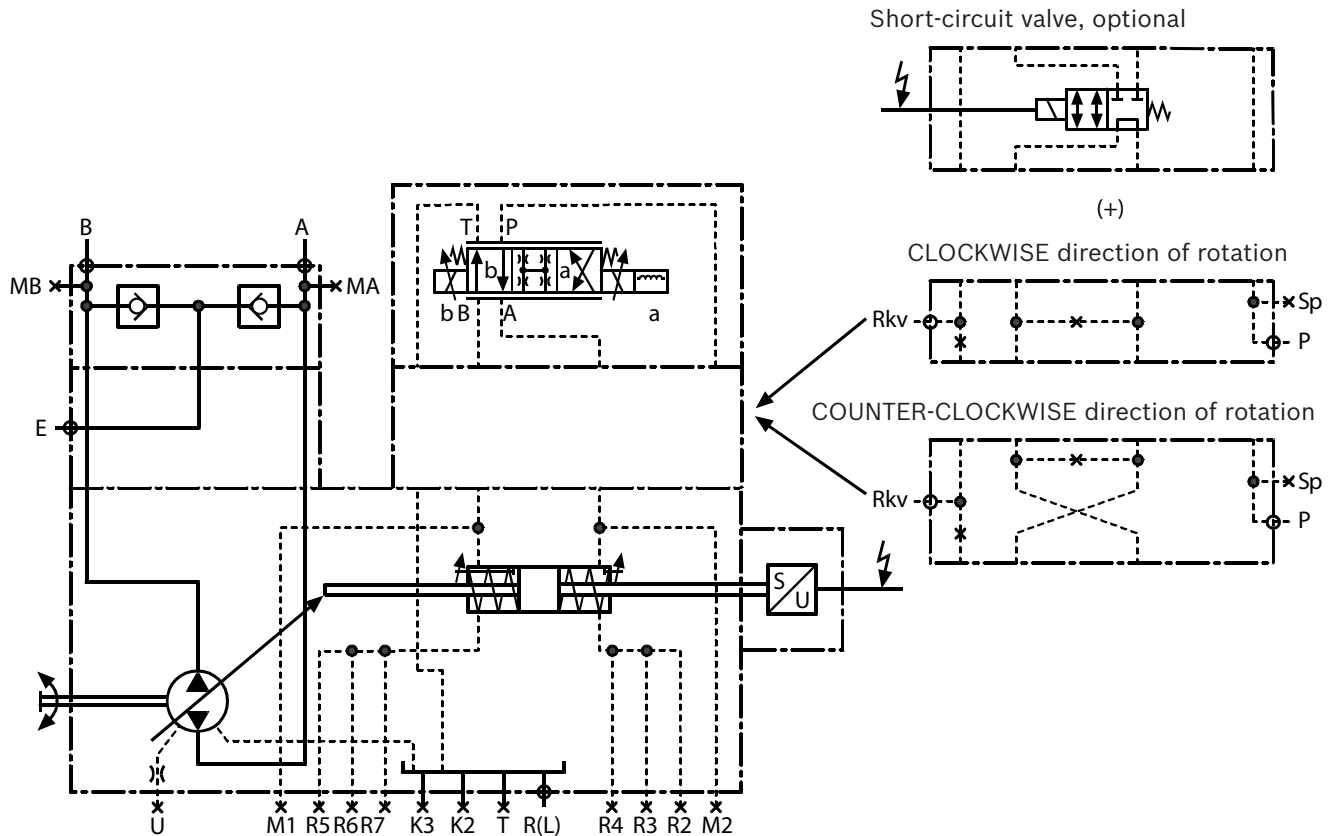

Fig. 2: Pump control in the closed circuit with connection of the swivel angle transducer

Optionally, a by-pass valve Z4WEH (WB152) (4/2 directional shut-off valve) can be installed additionally between the sandwich plate and the proportional valve.



The by-pass circuit does not feature an emergency stop function! The by-pass circuit serves for adjustment and setting purposes in the de-pressurized zero position, but without a defined return during high-pressure operation.

Pump combinations (master/slave)

When several pumps deliver fluid into a system, they have to be connected in parallel. If pressure control is to be activated for them, it is useful to apply the master/slave principle. To this end, one pump is used as master, and all the other pumps are hooked up as slaves. One pressure transducer can be connected to several control electronics. In the case of pressure sensors with current interface, the resulting load impedance must be taken into account (load impedance per control electronics 100 Ω). The voltage drop across an input is 3.5 V at 20 mA and 1.7 V at 4 mA. The master board realizes closed-loop swivel angle control as well as closed-loop pressure control and power limitation. For this, the swivel angle, pressure and power command values have to be provided accordingly. The swivel angle command value (b2) of all slave boards is to be connected to the output (d32) of the master board. For master/slave operation, the swivel angle command value (b4) of all slave boards must be connected to the output (b28) of the master board. The pressure controller must then only be adapted on the master board. The slave boards are always operated using the resulting command value of the master board.

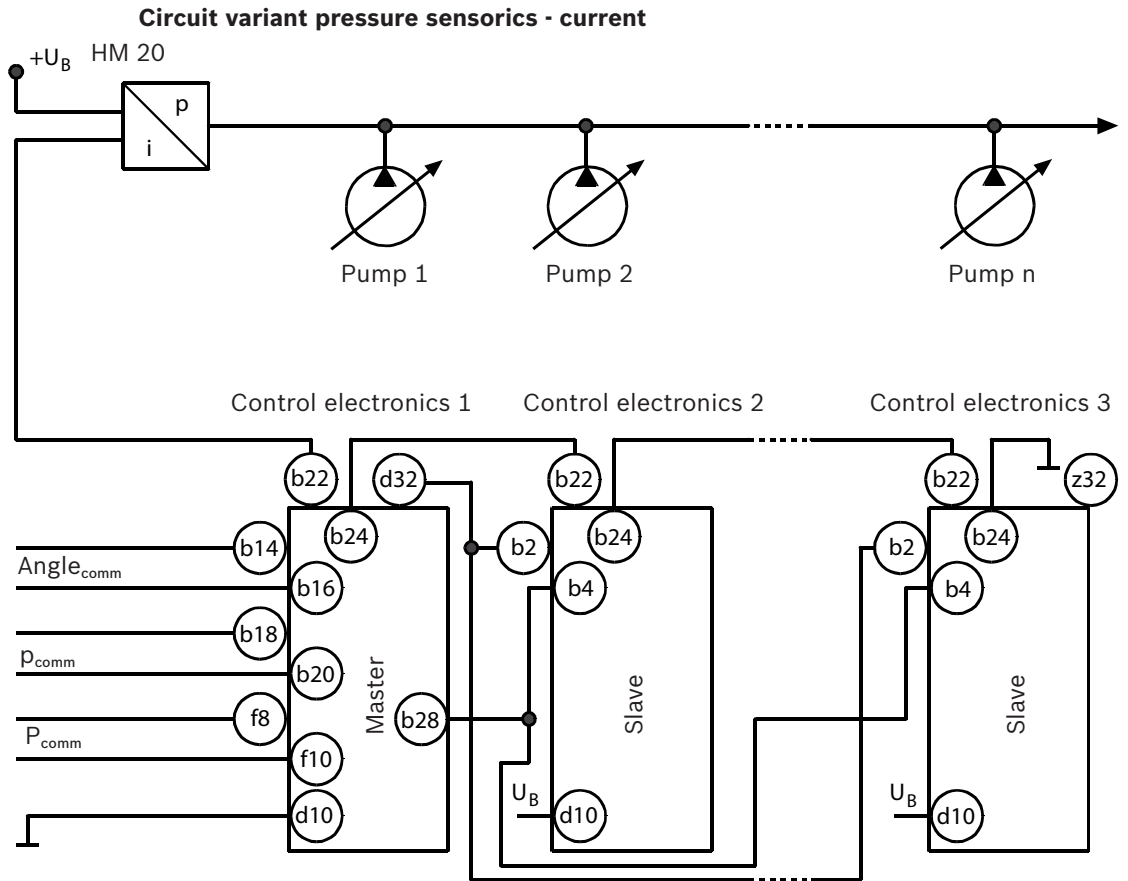

Fig. 3: Circuit variant pressure sensorics - current

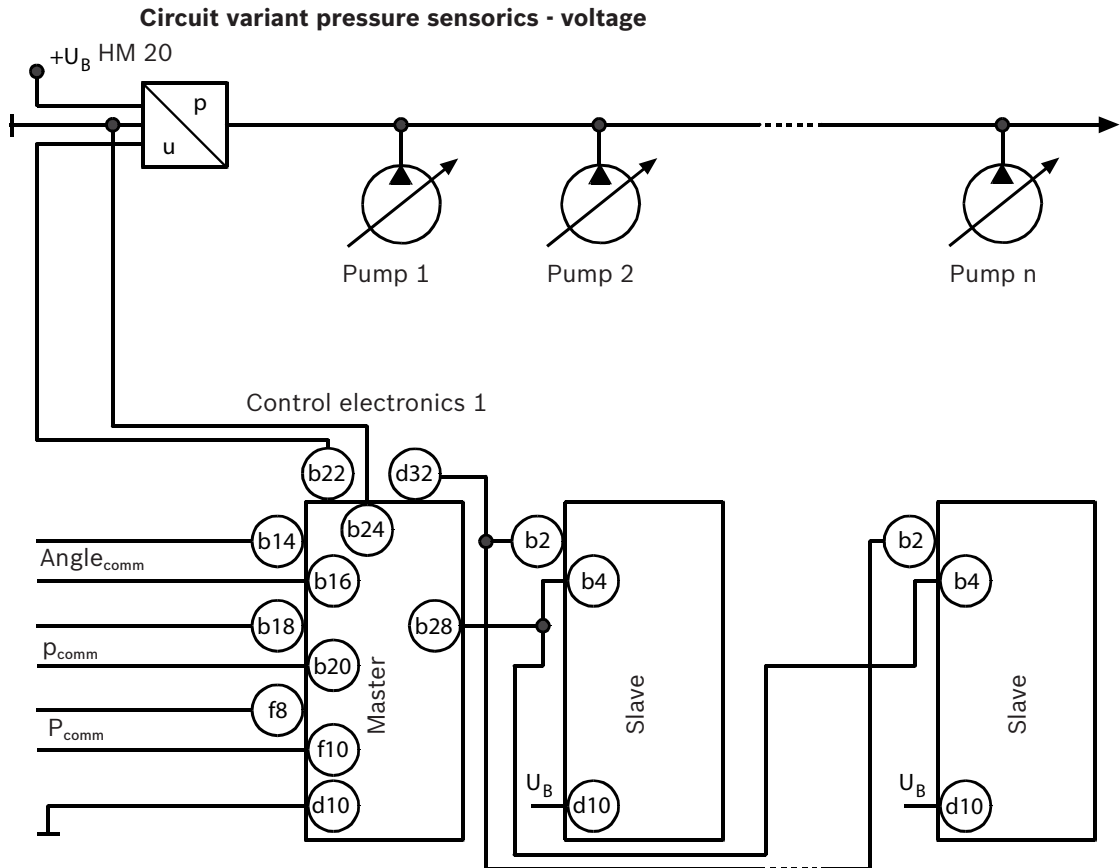

Fig. 4: Circuit variant pressure sensorics - voltage

It is also possible to realize a master/slave system using a bus system (Profibus/ DeviceNet/CANopen). In this case, parameters are not transmitted via analog inputs and outputs, but directly over the bus system. This is illustrated in the following Figure.



Combinations of analog inputs and bus communication are possible as well.

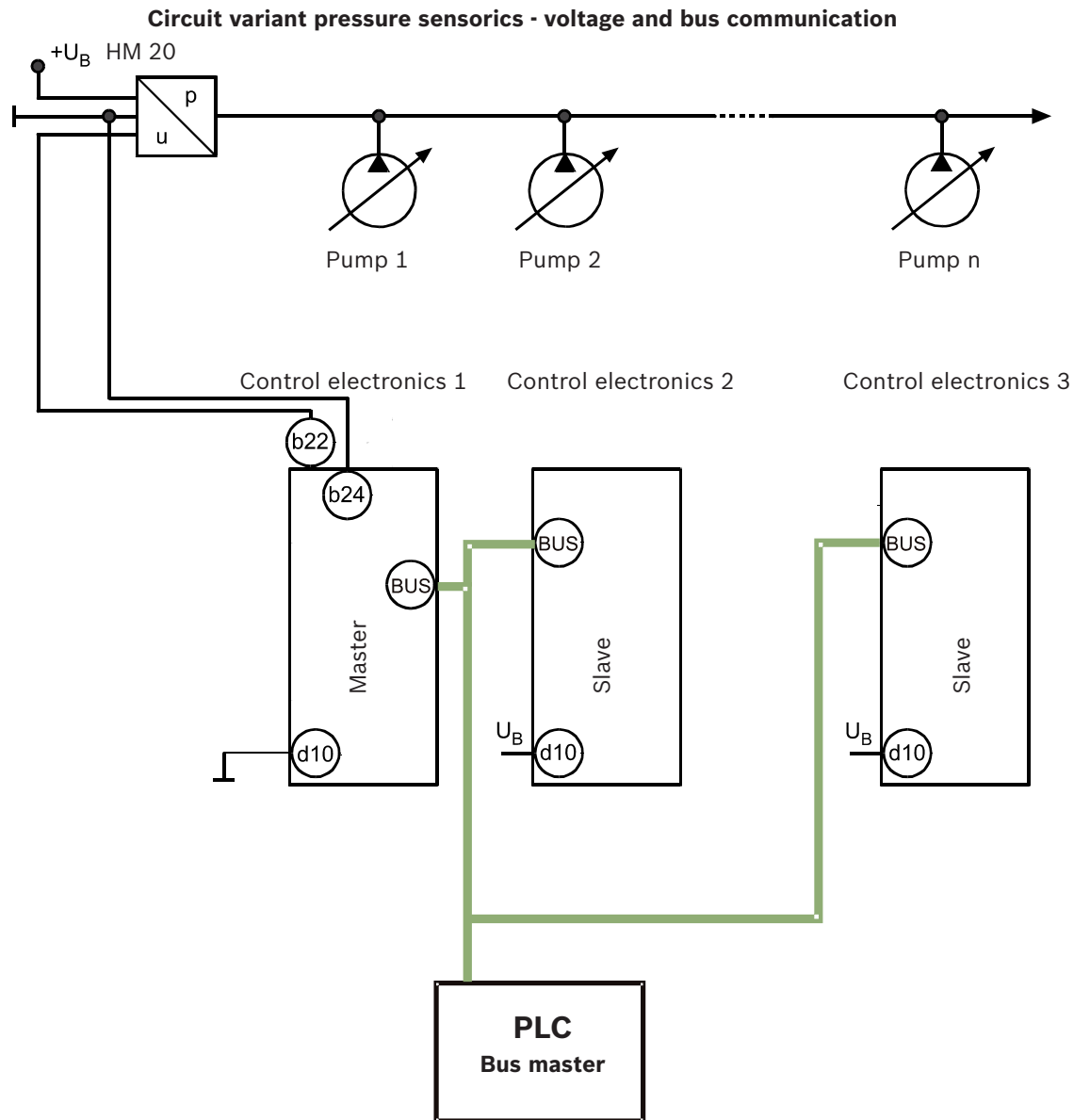

Fig. 5: Circuit variant pressure sensorics - voltage with bus communication

5.2.2 Block circuit diagrams

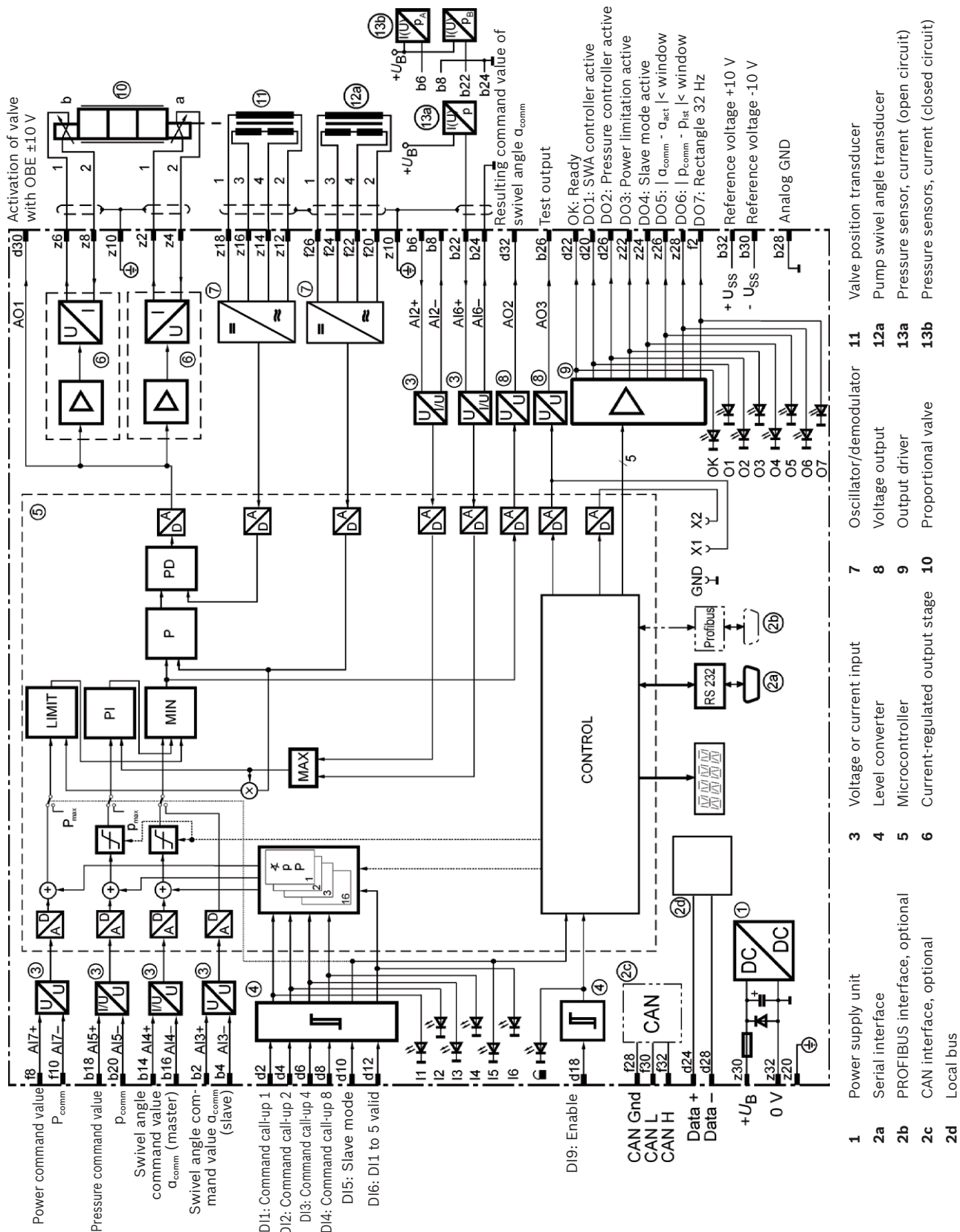

Fig. 6: VT-PCD-1-1X/V0/1-0-1 for axial piston pump A4VS...HS4 with swivel angle transducer AWX F004 D01

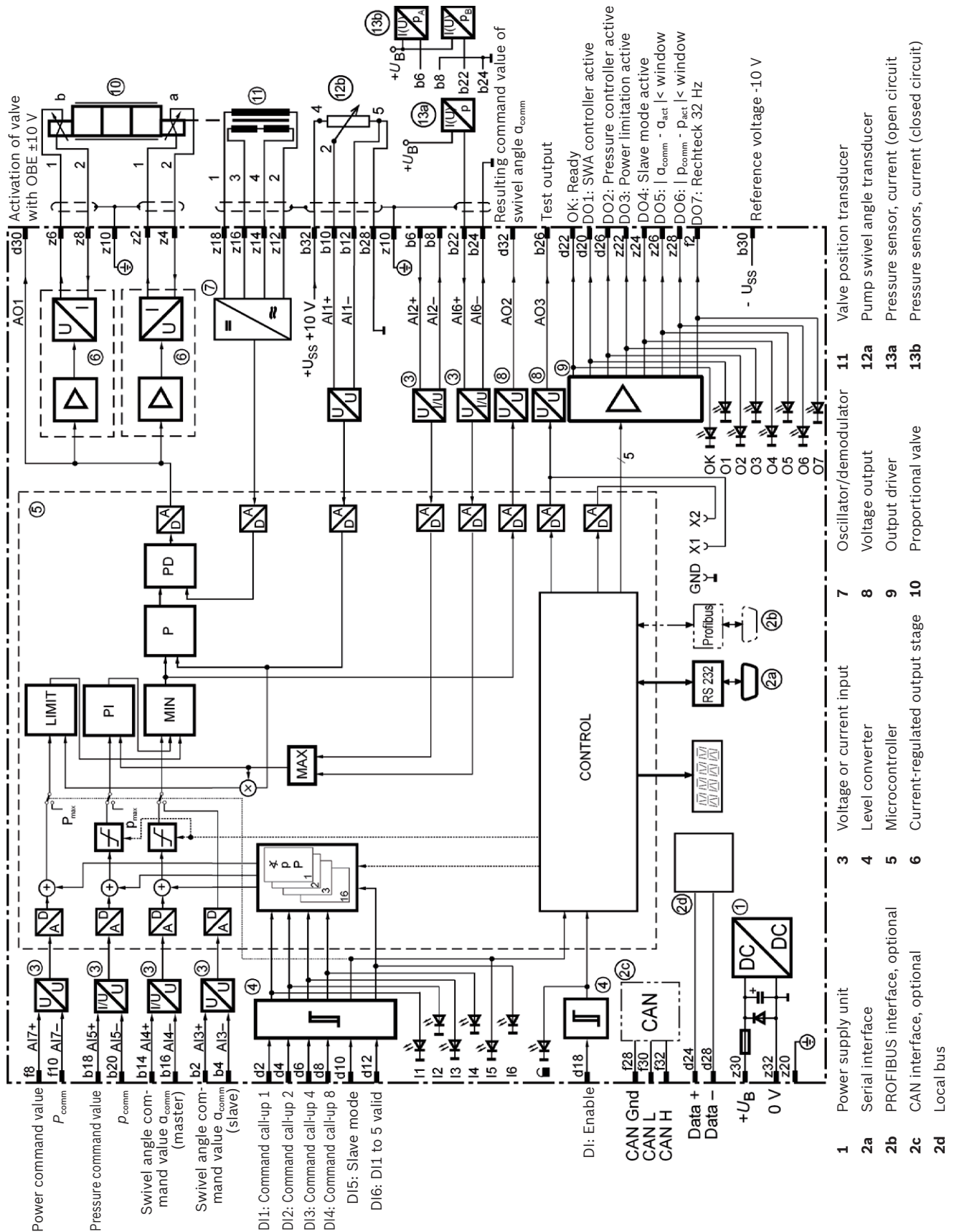

Fig. 7: VT-VPD-1-1X/V0/1-0-1 for axial piston pump A2V...EO4 (housing pump) with swivel angle transducer MCP-40/4742

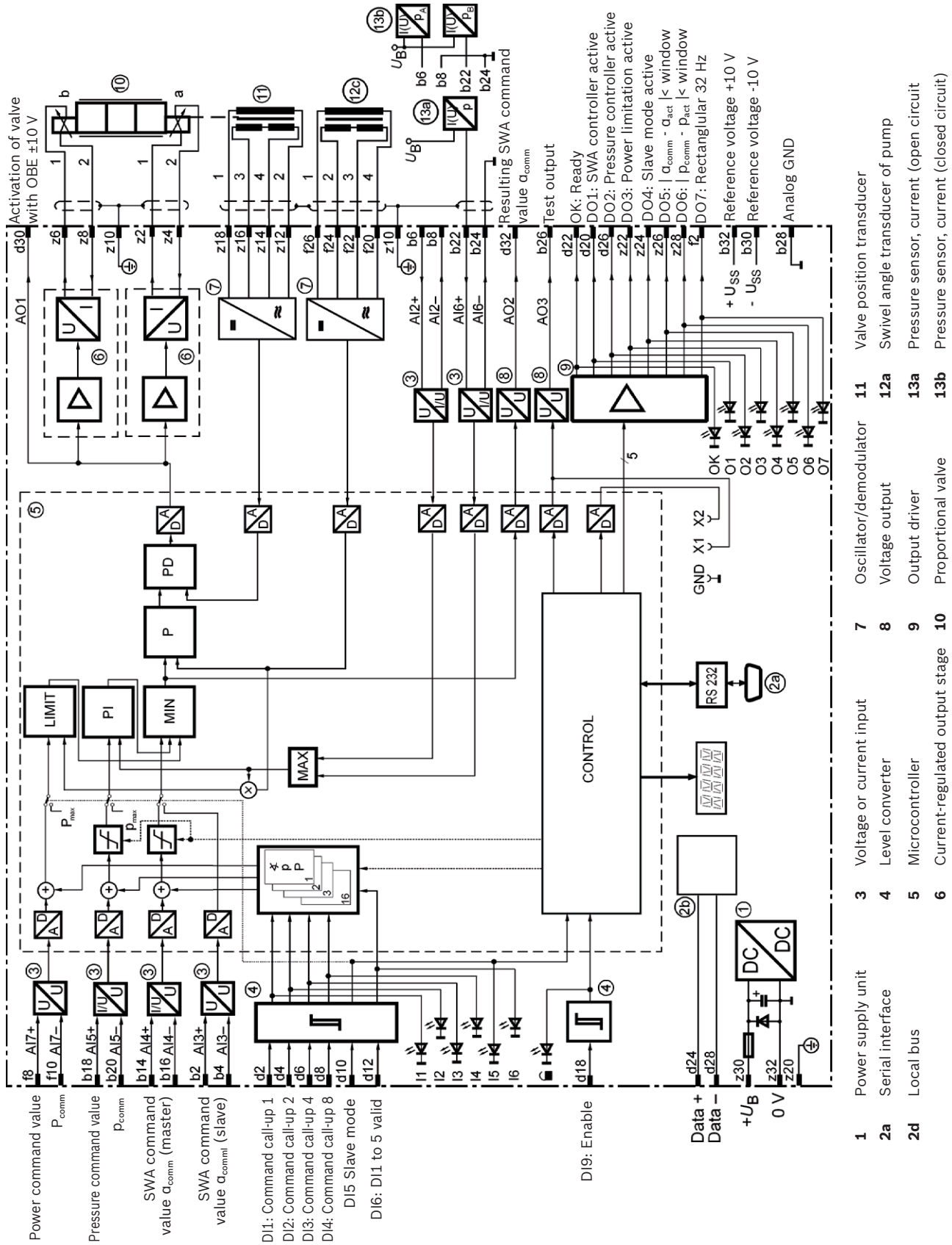
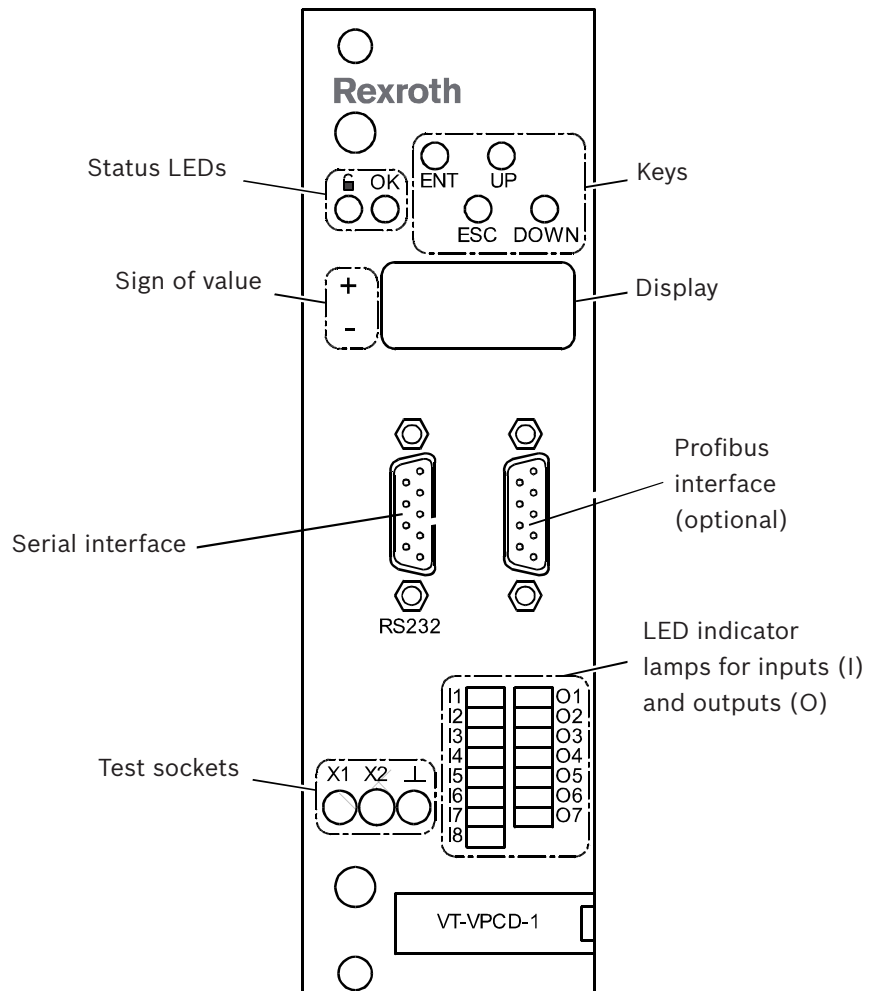

Fig. 8: VT-PCD-1-1X/V100/1-0-1 for axial piston pump A2V...EO4 (built-in pump) with swivel angle transducer DK100

5.2.3 Display and operating elements and test sockets



VPCD_08

Fig. 9: Front panel elements

The freely configurable test sockets X1/X2 provided on the front panel serve to indicate process signals.

Their configuration is described in the online help.

- LEDs** The following states are signaled by LEDs:
- LED “” (green): Enable active
 - LED “OK” (green): OK ready
 - LEDs “I1“...”I4” (yellow): Binary-coded command value call-ups
 - LED “I5” (yellow): Slave mode
 - LED “I6” (yellow): Command valid
 - LED “I7” (yellow): Not assigned

Keys Using keys ENT, ESC, UP, DOWN you can navigate within the menu and access the individual parameters and error messages. The keys are described in detail in Chapter 9.2 “Operating the control electronics VT-VPCD“ from page 24 onwards.

Sign of display value The signs +/- light up together with the value shown on the display (positive or negative).

Display In conjunction with the 4 keys, the display serves to display and change parameters and is used for diagnostic purposes. The VT-VPCD can be accessed via a menu structure. The parameter values can be displayed and changed. Moreover, error messages are shown on the display.

Serial interface Software is configured via the serial interface. The graphic below shows the pinout of the D-SUB socket on the front panel.

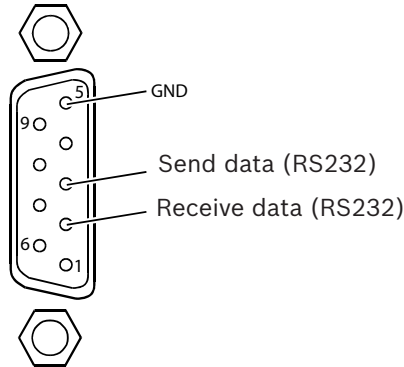

Fig. 10: Pinout of the D-SUB socket RS232

Profibus interface (optional) The connection for Profibus communication is made using a 9-pin D-SUB socket on the front panel (optional). The graphic below shows the pinout of the D-SUB socket for Profibus.

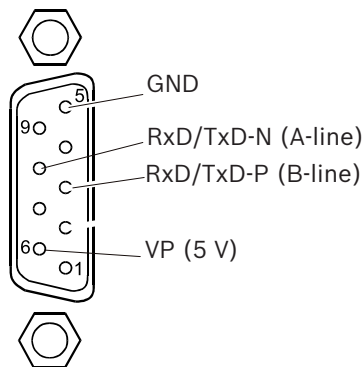

Fig. 11: Pinout of Profibus D-SUB socket

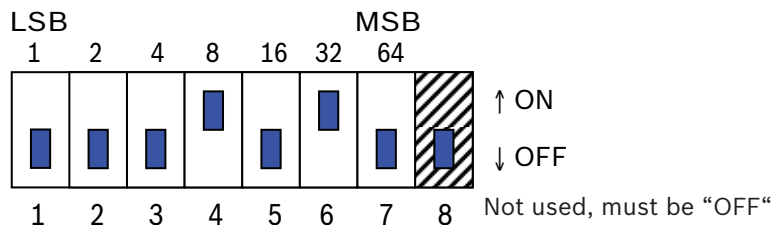

Fig. 12: Address setting for Profibus

The set address is read in once after the supply voltage was applied. A change of address is therefore only valid after a power-on reset of the card.

When assigning the addresses, take in any case care that a clear and unique address is assigned to each Profibus station.

For further information on the handling of Profibus parameters, please refer to the documentation "RE 30028-01-Z".

LEDs inputs/outputs When an input or output is active, the corresponding LED is lit.

Table 6: LEDs on the front panel

LED	Designation	VT-VPCD-1-1X
I1	DI1	Command call-up 1
I2	DI2	Command call-up 2
I3	DI3	Command call-up 4
I4	DI4	Command call-up 8
I5	DI5	Slave mode
I6	DI6	Command call-up 1 - 5 valid
O1	DO1	SWA controller active
O2	DO2	Pressure controller active
O3	DO3	Power limitation active
O4	DO4	Slave mode active
O5	DO5	$ \text{Angle}_{\text{comm}} - \text{angle}_{\text{act}} < \text{window}$
O6	DO6	$ \text{p}_{\text{comm}} - \text{p}_{\text{act}} < \text{window}$
O7	DO7	Rectangular 32 Hz

Test sockets The signals of the control variables can be output at the test sockets.

X1	Test jack 1 (output AO3)
X2	Test jack 2
⊥	Test jack GND

5.2.4 Pinout of the edge connector

The edge connector is a 64-pin, type G connector (DIN 41612). The pinout of the edge connector is not fully downward compatible with existing older control electronics (VT 12350-3X or VT 12352-3X). Changes, if any, in the pinout were, however, made so that damage is avoided, when older electronics are replaced by a new variant.

Row d Table 7: Pinout of edge connector row d

Pin	Signal	Description	Function VT-VPCD
2	DI1	Discrete input	Command call-up 1
4	DI2	Discrete input	Command call-up 2
6	DI3	Discrete input	Command call-up 4
8	DI4	Discrete input	Command call-up 8
10	DI5	Discrete input	Slave mode
12	DI6	Discrete input	DI 1 - 5 valid
14	DI7	n.c.	n.c.
16	DI8	n.c.	n.c.
18	DI9	Enable	Enable
20	DO1	Discrete output	SWA controller active
22	OK	Ready	Ready

Pin	Signal	Description	Function VT-VPCD
24	Data +	Local CAN bus input/output	Local CAN bus input/output
26	DO2	Discrete output	Pressure controller active
28	Data -	Local CAN bus input/output	Local CAN bus input/output
30	AO1	Analog output	Activation of valve with OBE
32	AO2	Analog output	Resulting swivel angle command value

Table 8: Pinout of edge connector row b

Pin	Signal	Description	Function VT-VPCD
2	A13+	Differential input	Swivel angle command value (slave) + (U)
4	A13-	Differential input	Swivel angle command value (Slave) - (U) reference
6	A12+	Differential input	Actual pressure value (A) + (U/I) or (U)
8	A12-	Differential input	Actual pressure value (A) - (U/I) or (U) reference
10	A11+	Differential input	Actual value MCP-40/4742 + (pin 2)
12	A11-	Differential input	Actual value MCP-40/4742 - (Pin 5)
14	A14+	Differential input	Swivel angle command value + (U/I) or (U)
16	A14-	Differential input	Swivel angle command value - (U/I) or (U) reference
18	A15+	Differential input	Pressure command value + (U/I) or (U)
20	A15-	Differential input	Pressure command value - (U/I) or (U) reference
22	A16+	Differential input	Actual pressure value (B) + (U/I) or (U)
24	A16-	Differential input	Actual pressure value (B) - (U/I) or (U) reference
26	AO3	Analog output	Test output (X1)
28	AGND	Analog GND	Analog GND
30	REF-	Reference voltage -10 V	Reference voltage -10 V
32	REF+	Reference voltage +10 V	Reference voltage +10 V

Row z Table 9: Pinout of edge connector row z

Pin	Signal	Description	Function VT-VPCD
2	MA+		Solenoid A+
4	MA		Solenoid A
6	MB+		Solenoid B+
8	MB		Solenoid B
10	Shield	Shield	Shield
12	L10-		Valve position transducer supply - (pin 2)
14	L11 -		Valve position transducer actual value - (pin 4)
16	L11+		Valve position transducer actual value + (pin 3)
18	L10+		Valve position transducer supply + (pin 1)
20	System ground		System ground
22	DO3	Discrete output	Power limitation active
24	DO4	n.c.	Slave mode active

Pin	Signal	Description	Function VT-VPCD
26	DO5	Discrete output	command angle - actual angle < window
28	DO6	Discrete output	command p - actual p < window
30	U _B		Supply voltage
32	LO		Ground

Row f Table 10: Pinout of edge connector row f

Pin	Signal	Description	Function VT-VPCD
2	DO7	Discrete output	Rectangular 32 Hz
8	AI7+	Differential input	Power command value + (U)
10	AI7-	Differential input	Power command value (U) reference

For type AWXF004D01

20	L2O-	LVDT2 pump pin 2	Supply GND
22	L2I -	LVDT2 pump pin 4	Actual value GND
24	L2I+	LVDT2 pump pin 3	Actual value signal
26	L2O+	LVDT2 pump pin 1	Supply signal

For type DK 100

20	L2O	LVDT2 pump pin 4	Supply GND
22	L2I	LVDT2 pump pin 3	Actual value GND
24	L2I+	LVDT2 pump pin 2	Actual value signal
26	L2O+	LVDT2 pump pin 1	Supply signal
28	GND_CAN	CAN bus reference	CAN bus
30	CANL	CAN bus input/output	CAN bus
32	CANH	CAN bus input/output	CAN bus

5.3 Identification of the product

At the side along the edge connector you can find a sticker that shows the most important details.

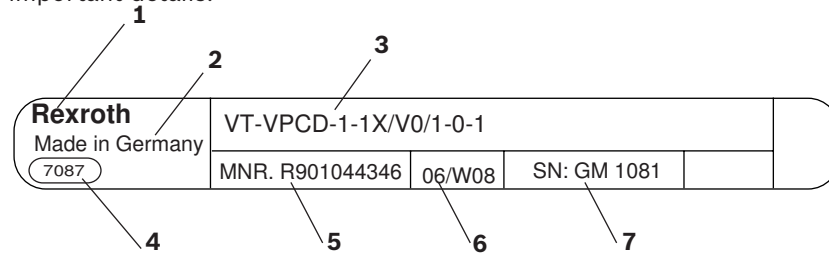

- | | |
|------------------------------|-----------------------------|
| 1 Word mark | 5 Material number |
| 2 Country of origin | 6 Date of production |
| 3 Material short text | 7 Serial number |
| 4 Plant | |

6 Transport and storage

Transport and store the control electronics VT-VPCD in the antistatic packaging, in which it is delivered. Observe the notes on top of the packaging as well as the notes in Chapter 2 "Safety instructions". In any case, when storing and transporting the electronics, adhere to the ambient conditions given in the technical data in the data sheet.

6.1 Storing the VT-VPCD

To prepare the control electronics for storage and further use, proceed as follows:

- ▶ Only use the original packaging for storing.
- ▶ Observe the permitted storage temperature range of -20 °C to +70 °C.
- ▶ Protect the VT-VPCD against dust and humidity.

7 Installation

CAUTION

Fault currents and short-circuits!

Impaired safety and malfunction.

- ▶ The surroundings must be free from conductive contamination (acids, lyes, corrosive agents, salts, metal vapors, etc.), and the device must not be exposed to them. Generally, rule out deposits according to protection class IP 65.

Cables lying around!

Risk of stumbling.

- ▶ Route cables and lines so that they cannot be damaged and nobody can stumble over them.

NOTICE

Great differences in potential!

Risk of destruction of the control electronics VT-VPCD by plugging in or removing the electronics while connected to the power supply.

- ▶ Disconnect the relevant system part from the power supply before you plug, remove or connect the electronics. Damage to the electronics caused by incorrect installation is not covered by the warranty!
- ▶ Observe the protection class, the voltage supply and ambient conditions as specified in data sheet RE 30028.

Electrostatic discharge!

Risk of destruction of the control electronics VT-VPCD.

- ▶ Keep the control electronics in the antistatic packaging until it is installed and observe the notes on top of the packaging when unpacking the electronics.

Radiated interference!

Risk of malfunction.

- ▶ Keep a sufficient distance to radio equipment (>> 1 m).
- ▶ Do not install solenoid and signal cables near power cables.
- ▶ Shield command and actual value cables. Leave the shield open at one end and connect it to system ground on the card side.

7.1 Unpacking

- ▶ Only remove the card at a protected workplace.
- ▶ Handle the control electronics at the front panel and do not touch any electrical components.

7.2 Required tools

No special tools are required for installing the electronics.

7.3 Installation conditions

The control electronics VT-VPCD is designed for installation in a 19" rack or an open card holder. Suitable card holders are listed in the following Chapter 7.4 "Recommended accessories".

- ▶ Provide an operating voltage of 24 VDC.
- ▶ Adhere to the ambient temperature range permitted according to the data sheet.

7.4 Recommended accessories

For connecting the control electronics VT-VPCD we recommend the use of the following accessories, which are not included in the scope of supply, but which you can order separately from Bosch Rexroth:

Table 11: Accessories

Component	Material number	Data sheet
VT 12302-3X/1, closed card holder, 64-pin edge connector	R900784153	RE 30103
VT 12302-3x/2-64G Dual CARD HOLD	R978009974	RE 30103
Open card holder VT 3002-1-2X/64 G ¹⁾	R900016484	RE 29928
Power supply unit VT-NE30-2X/ ²⁾	R901082348	RE 29929
Mating connector for proportional valve solenoid a, color: gray	R901017010	
Mating connector for proportional valve solenoid b, color: black	R901017011	
4-pin mating connector for swivel angle transducer AWWF004D01	R900023126	
Serial interface cable for control electronics	R900776897	
USB converter for connection to the serial interface	R901066684	

¹⁾ The open card holder may only be used for installation in a control cabinet; it does not provide electric shock protection.

²⁾ If no voltage supply is provided on the system side.

7.5 Installing the VT-VPCD

Please observe the following notes when installing the VT-VPCD control electronics:

- For the installation, observe the notes given in the data sheet on applied standards and operating conditions.
- Use low-capacitance cables.
- Install cable connections without intermediate terminals whenever possible.
- Install sensor cables separately.
- The presence of electromagnetic sources of interference (e.g. frequency converter) in the direct vicinity of the control electronics is not permitted.
- The distance to aerial lines, radio sources and radar equipment must be at least 1 m.
- Do not install solenoid and signal cables near power cables.
- Use shielded cables (EMC-compliant) as valve cables.
- Execute the installation so that when the differential inputs are used both inputs are activated or deactivated simultaneously.
- Use relays with gold-plated contacts for switching command values (small voltages, small currents).
- Do not use adhesives, sealants or insulating agents that contain silicone.
- The system ground is an essential integral part of EMC protection of the control electronics. Here, interference, which is transported to the control electronics via data and voltage supply cables, is dissipated. This function can only be ensured, if the

system ground itself does not inject interference into the control electronics. Bosch Rexroth recommends that also solenoid cables be shielded.

- Ensure maintenance-friendly installation, i.e. ease of access to the connection cables. The connection side must be freely accessible. The cable ends should be sufficiently long in order that the control electronics can also be removed in the wired condition.
- Before installing the control electronics note down the details on the nameplate. If nameplates are no longer visible or legible after the installation you have this data at hand at any time.

When installing the control electronics VT-VPCD, proceed as follows:

1. Disconnect the relevant rack from the power supply.
2. Only remove the card from its package at a protected workplace.
3. Open the packaging of the control electronics and hold the card by the front panel and remove it from the packaging.
4. Slide the control electronics into the guide rails of the rack without using excessive force as shown on the Figure below.
5. Snap the controller card in place by gently pressing on the front panel.

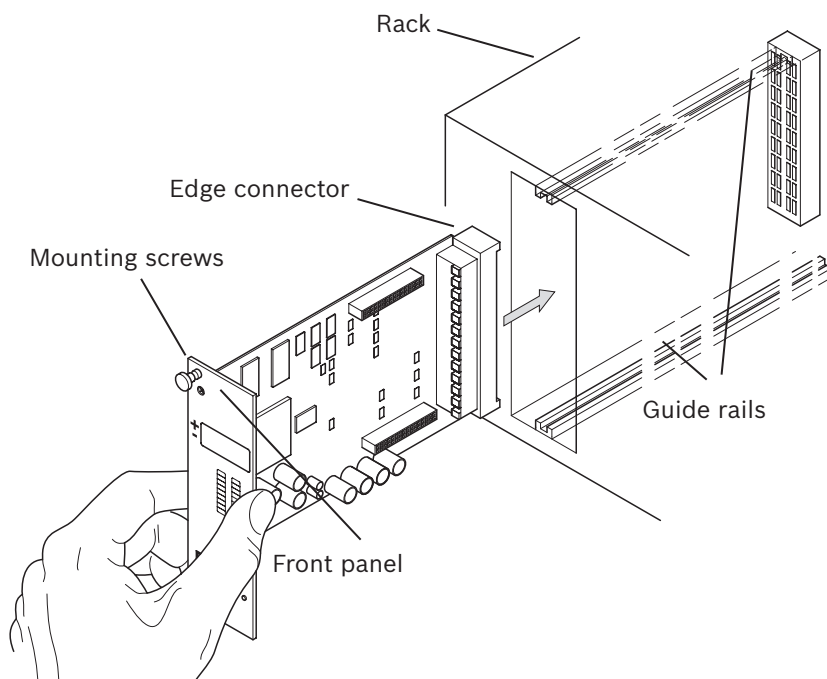

Fig. 13: Installing the control electronics VT-VPCD

6. Tighten the two mounting screws on the front panel.

The control electronics is now correctly installed.

7.5.1 Installing the local bus

The local bus provides the connection between the individual electronics of the HACD family.



You can use the local bus to configure another card connected to the local bus with the help of Bodac.

However, never send firmware over the local bus to another electronics card to update the latter.

You can connect up to 32 stations. A clear bus address must be assigned to each control electronics.

The connection is established using a CAN protocol with a baud rate of 250 kbit.

The maximum length of the most distant control electronics must not exceed 280 m.

Moreover, the maximum length of the branch lines of 1 m must be observed.

The data are transmitted over a shielded twisted-pair cable.

For the setup, two bus terminal resistors of 120 Ohm are required.

Max. length = 280 m

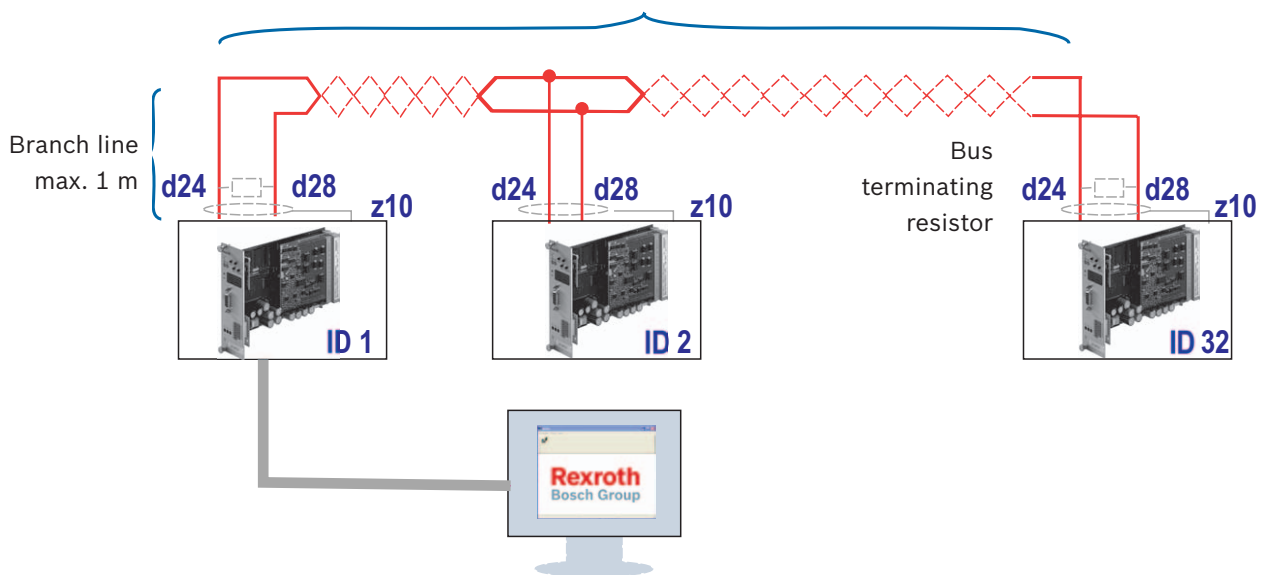

Fig. 14: Schematic structure of "local bus"

7.5.2 Connecting solenoids and sensorics

Solenoids of the proportional valve

- Lay solenoid cables of the proportional valve separately, away from other cables; in particular, they must be separated from cables of the inductive position transducers.

We recommend the use of shielded solenoid cables. Recommended cable type: LiYCY 1.5 mm² up to 50 m length.

When double-shielded cable is used, the outer shield can be terminated at the entry into the control cabinet, the inner shield can be terminated at the control electronics.

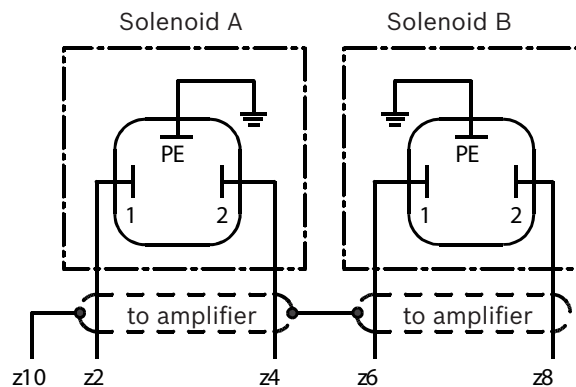

Fig. 15: Connection of the solenoids to the control electronics

Use a mating connector CECc 75301-803-A002FAH3008-G according to DIN EN 175 301-803 and ISO 4400 for connecting the solenoids.

- Solenoid “a”, mating connector, color: gray, separate order stating material no. R901017010
- Solenoid “b”, mating connector, color: black, separate order stating material no. R901017011

Valve position transducer

The transducer is connected using a 4-pin mating connector Pg7-G5W1F, which can be ordered separately stating material no. R900023126.

Up to a length of 50 m we recommend the use of 4 x 0.25 mm² connection cables of type LiYCYCY. When double shielded cable is used, the outer shield can be terminated at the entry into the control cabinet, the inner shield can be terminated at the control electronics.

The shield needs only to be connected to pin z10 of the edge connector on the supply side.

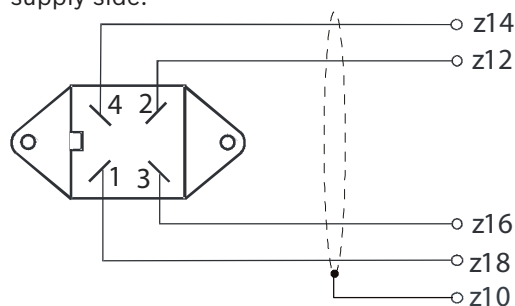

Fig. 16: Connection of the valve position transducer to the control electronics (viewed to connection side)

Swivel angle transducer

A4VS...HS4: Type AWXF004D01

The Figure below shows the connection of the swivel angle transducer to the pump.

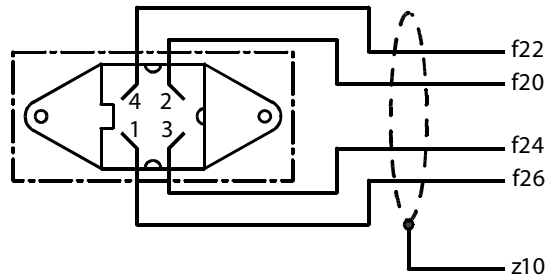

Fig. 17: Connection of swivel angle transducer AWXF004D01

The transducer is connected using a 4-pin mating connector Pg7-G5W1F, which must be ordered separately stating material no. R900023126.

Up to a length of 50 m we recommend the use of a connection cable 4 x 0.25 mm² of type LiYCYCY. When double shielded cable is used, the outer shield can be terminated at the entry into the control cabinet, the inner shield can be terminated at the control electronics.

Oil-immersed pump:

In conjunction with this pump type, the swivel angle transducer is installed oil-immersed. We recommend the use of cable type ÖLFLON® PTFE/FEP 4 x 0.25 mm² (by Lapp Kabel).

When double shielded cable is used, the outer shield can be terminated at the entry into the control cabinet, the inner shield can be terminated at the control electronics.

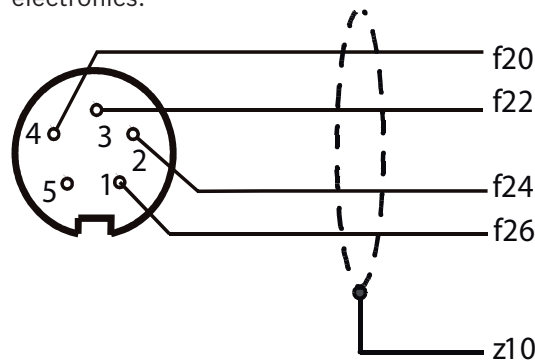

Fig. 18: Connection of swivel angle transducer DK100

Swivel angle transducer DK100 can be connected using a 5-pin mating connector 130-9 IEC-22 to DIN 45 321, which can be ordered separately.

Up to a length of 50 m we recommend the use of 4 x 0.25 mm² cables of type LiYCYCY as connection cable. When double shielded cable is used, the outer shield can be terminated at the entry into the control cabinet, the inner shield can be terminated at the control electronics.



Depending on the mechanical mounting of the swivel angle transducer, positive feedback may occur. In this case, exchange connections f20 and f26.

A2V...EO4 housing pump: Type MCP-40/4742

The Figure below shows the connection of the swivel angle transducer.

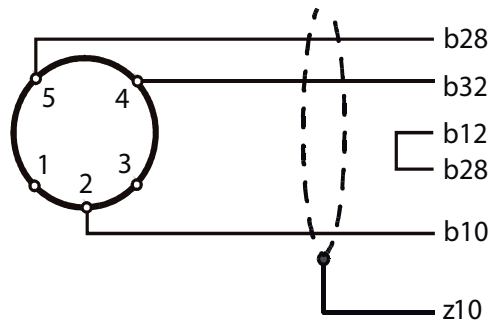

Fig. 19: Connection of swivel angle transducer MCP-40/4742

The transducer is connected by means of soldered connections. Up to a length of 50 m we recommend the use of 3 x 0.5 mm² cables of type LiYCYCY as connection cable. When double-shielded cables are used, the outer shield can be terminated at the entrance in the control cabinet, the outer shield can be terminated at the control electronics.

Pressure transducer side A and/or side B

For the voltage interface, pressure transducers of type HM 20 -2X/...H-K35 are used. Pressure transducer cables must be shielded. Cable type for the voltage interface: LiCYC 4 x 0.25 mm² up to a length of 50 m.

Voltage interface (HM 20)

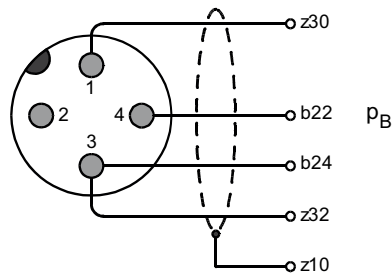

When 2 pressure transducers are used:

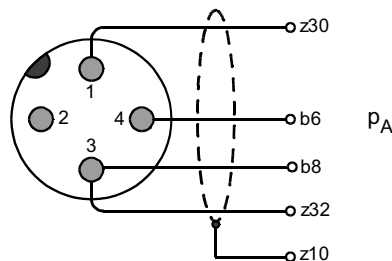
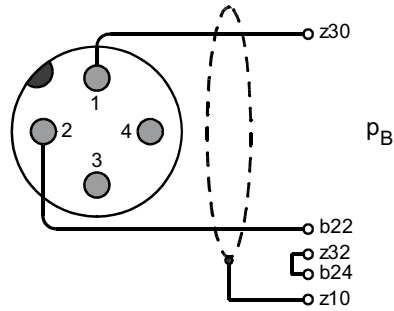

Fig. 20: Connection of pressure transducers HM 20 with voltage interface

For the current interface, pressure transducers of type HM 20-2X/...C-K35 are used. Pressure transducer cables must be shielded. Cable type for the current interface: LiCYC 2 x 0.25 mm² up to a length of 50 m.

Current interface (HM 20)



When 2 pressure transducers are used:

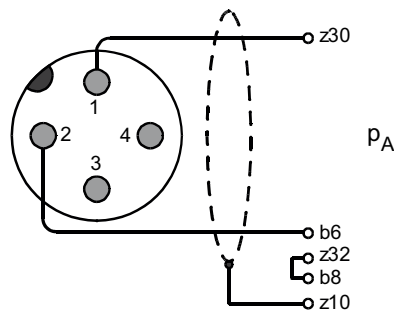

VPCD_03

Fig. 21: Connection of pressure transducers with current interface



Notes on the technical data and unit dimensions of pressure transducer HM 20, see data sheet RE 30272.

8 Commissioning

8.1 Initial commissioning

The proceeding for commissioning the control electronics VT-VPCD depends on various factors on site. For this reason, only basic steps for commissioning can be described in these instructions.

8.1.1 Establishing operational readiness

To establish operational readiness of the control electronics:

1. Thoroughly inspect the cabling
2. Apply voltage to the control electronics VT-VPCD

The control electronics runs a short internal function test.

The display of the control electronics shows the manufacturer's name in red scrolling text (during initial commissioning). See Chapter 5.2.3 "Display and operating elements and test sockets" on page 23.

8.1.2 Installing software BODAC

Software BODAC with ordering code SYS-HACD-BODAC-01/ (material number R900777335) can also be downloaded on the Internet (www.boschrexroth.de/HACD). This software can be used for initial commissioning and convenient operation of the control electronics and for making all the required settings for optimal operation of your VT-VPCD control electronics. The operating principle, integrated menus and program windows of the software are matched to suit the requirements of your control electronics. This makes the software very easy to use.

System requirements

IBM-compatible PC with the following minimum requirements:

- Operating system: Windows XP, Windows Vista, Windows 7.
- 256 MB RAM recommended
- Hard disk with at least 250 MB free hard disk space
- CD-ROM drive or Internet access
- RS232 interface (or USB port in conjunction with an USB converter, Mat. no. R901066684)

BODAC setup routine

Start the setup routine for installing software BODAC by executing the file "Setup.exe".

To install the software BODAC:

1. Insert the CD-ROM and locate the file "Setup.exe" or download the file on the Internet.
2. Double-click on file "Setup.exe" .

The setup program will load and display a start screen.

3. Follow the instructions on screen to run the setup routine.

BODAC is installed.



The program folder also contains a help file that describes the configuration and handling of your control electronics.

After having installed the BODAC software, proceed as follows:

1. Connect the serial interface cable (mat. no. R900776897) to the port of the control electronics VT-VPCD.
2. Plug the serial interface cable into the serial interface (COM) port of your PC or, if required, use a USB converter – Mat. no. R901066684.

The control electronics VT-VPCD and the PC are now connected.

3. Start software BODAC.
4. Perform the software-sided startup as described in the online documentation and RE 30028-01-B.

9 Operation

9.1 Indicator/operating elements and ports of the control electronics

The operating elements and ports on the front panel of the control electronics VT-VPCD can be used to query settings and parameters, connect external test instruments or connect the control electronics to a PC. For a detailed description of indicator and operating elements, see Chapter 5.2.3 “Display and operating elements and test sockets“ on page 23.

9.1.1 Menu tree for setup and parameters

The display is used for indicating command values and actual values as well as errors. For making any settings or parameter changes, BODAC has to be used. The following overviews are given on the next few pages:

- Menu tree “Parameters”
- Menu tree “Setup”
- Menu tree “Analog I/O” part 1
- Menu tree “Analog I/O” part 2
- Menu tree “Analog I/O” part 3
- Menu tree “Faults“
- Menu tree “Test jacks“

By pressing the key combination “Enter” and “ESC” you get to a menu with several entries at Level 1: “Setup“, “Analog I/O“, “Faults“ and “Test jacks“. Hold the keys depressed for about 5 seconds.

To get to the “Parameters“ menu, press the “Enter” key.

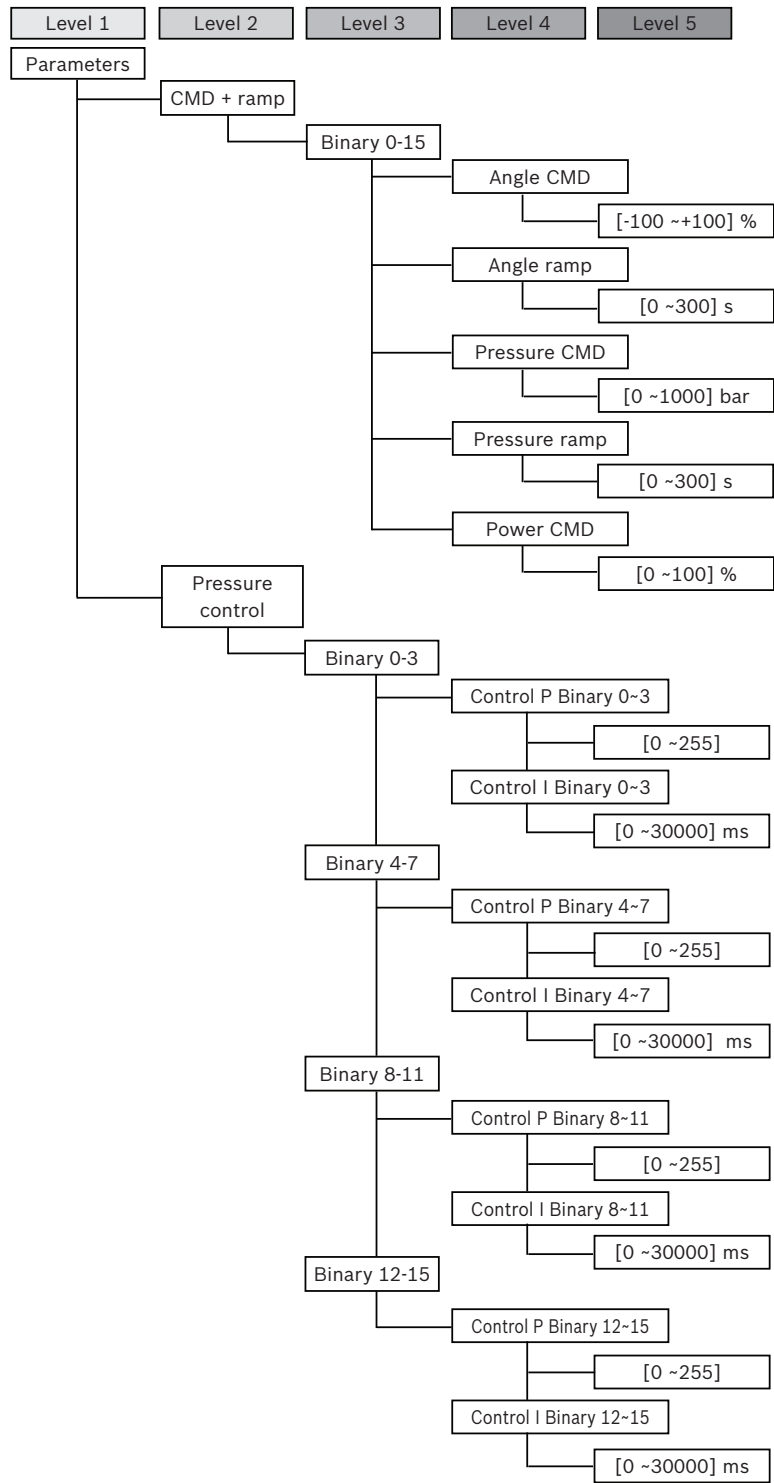

Fig. 22: Menu tree “Parameters“

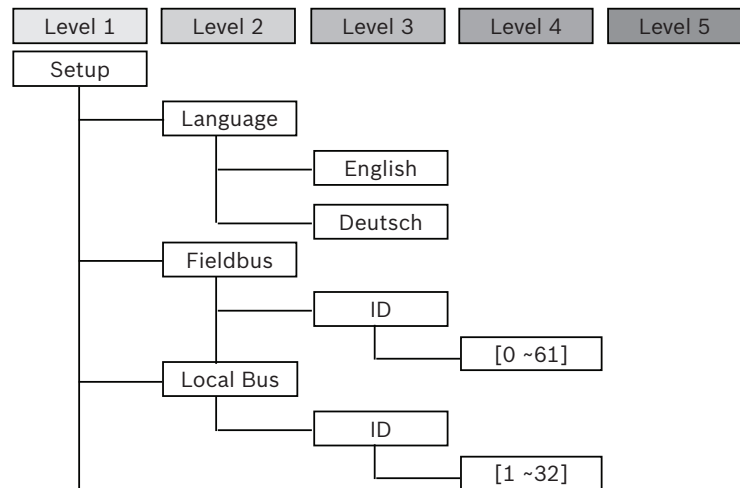
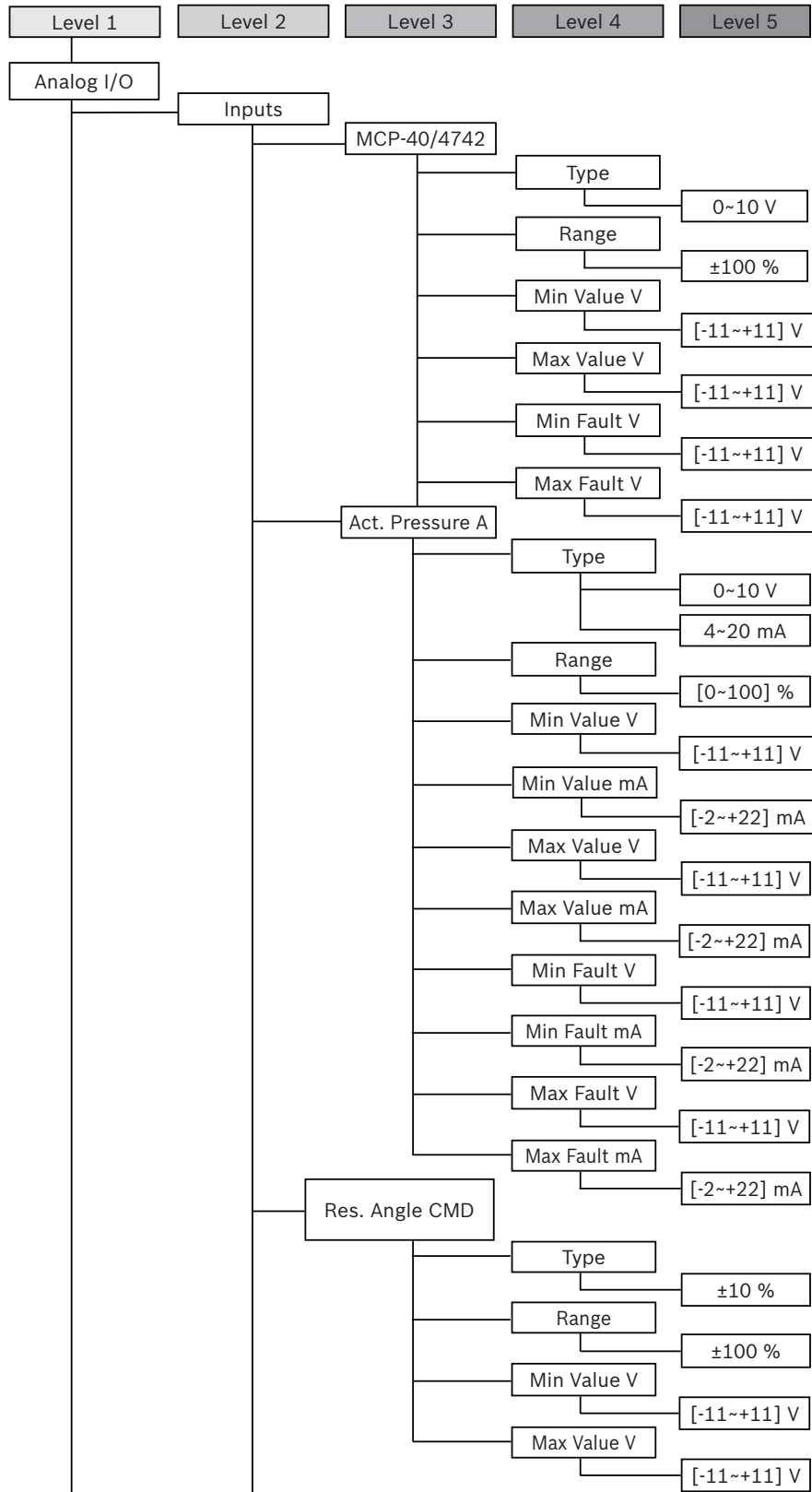

Fig. 23: Menu tree "Setup"



Changes to the bus ID require a re-initialization of the control electronics. After having successfully saved any changes to the bus ID, switch the electronics off and on again.

Press the keys “Enter” and “ESC” for 5 seconds to get to the menu “Analog I/O”.



Menu tree “Analog I/O” part 1

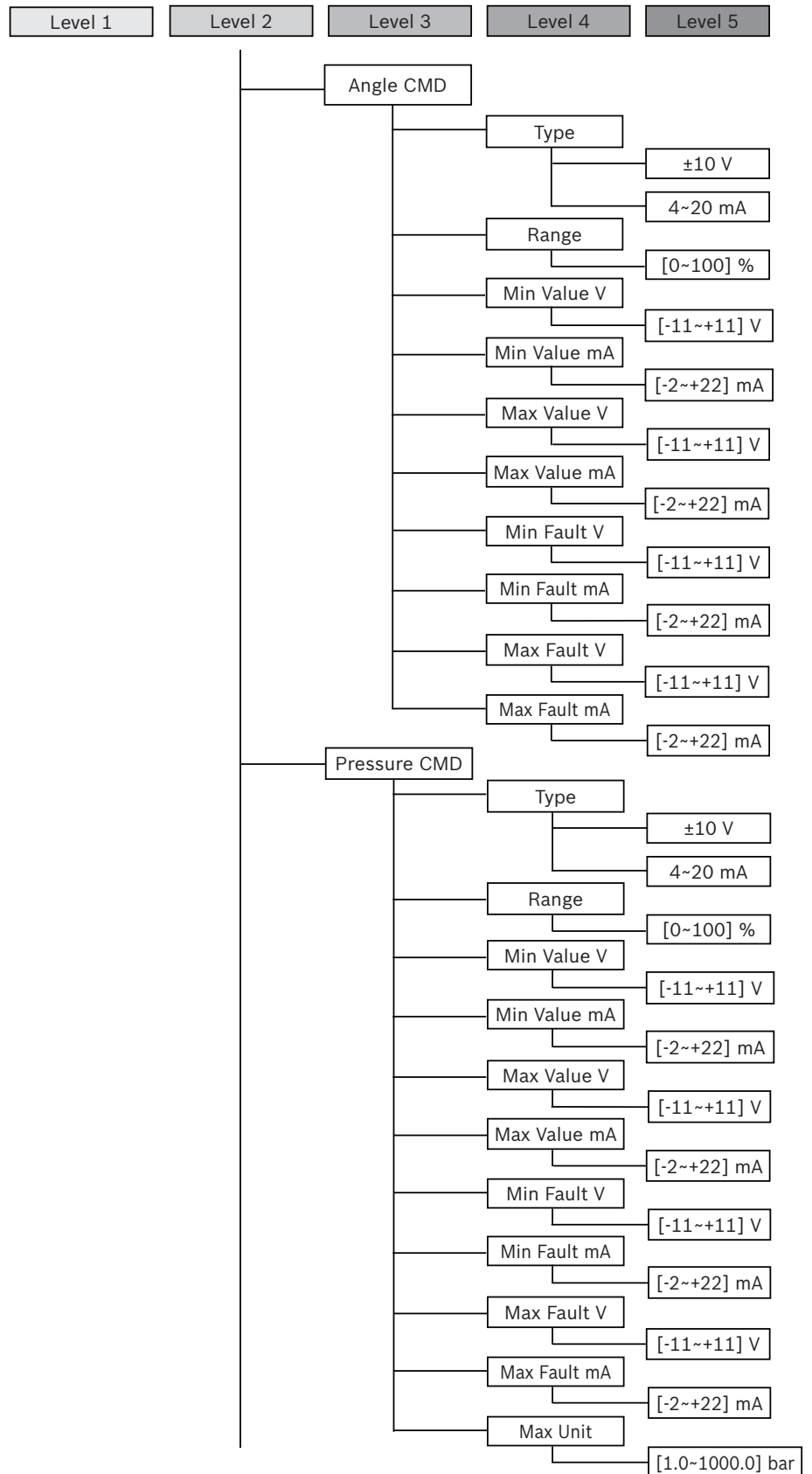

Fig. 24: Menu tree "Analog I/O" part 2

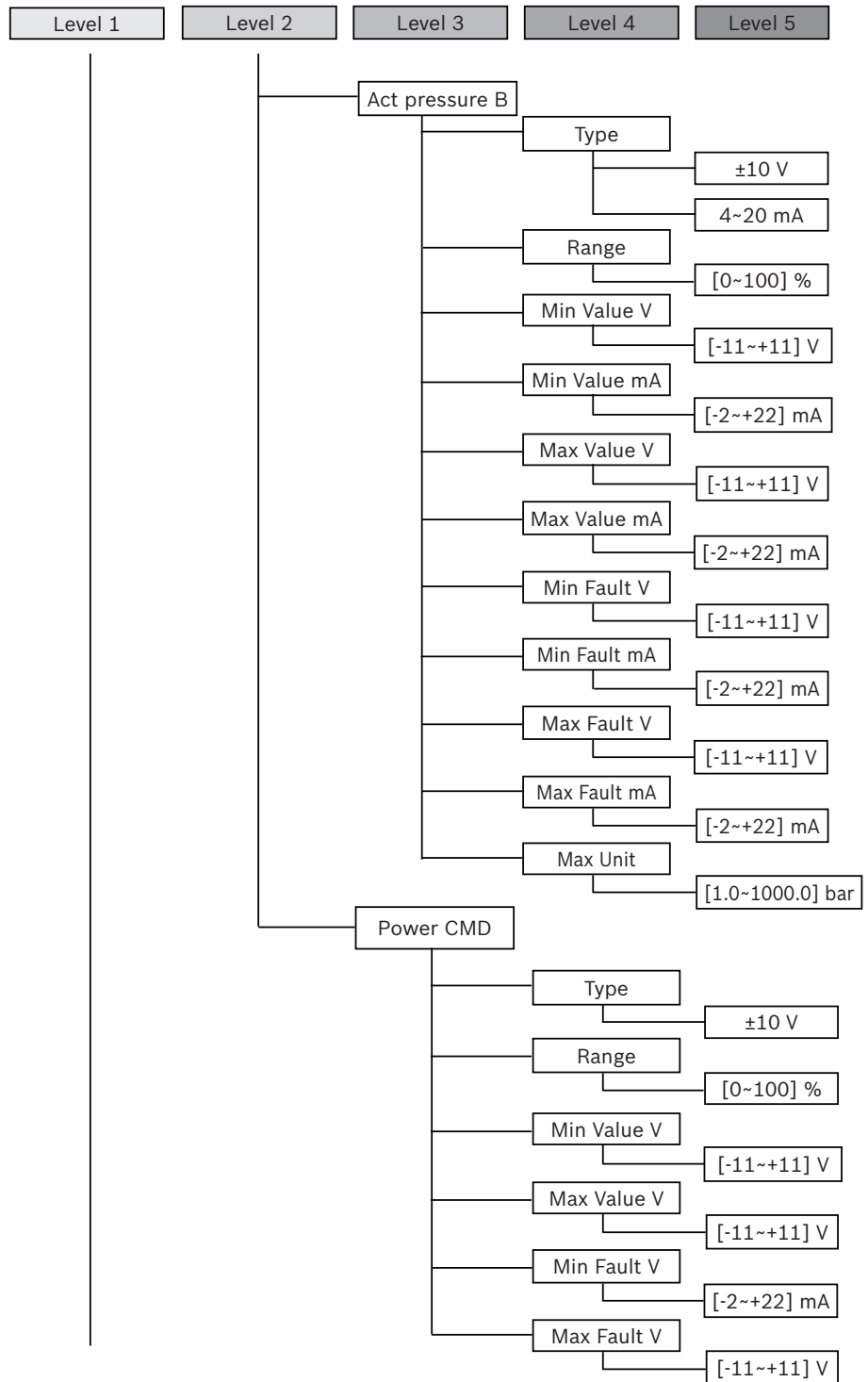

Fig. 25: Menu tree “Analog I/O” part 3

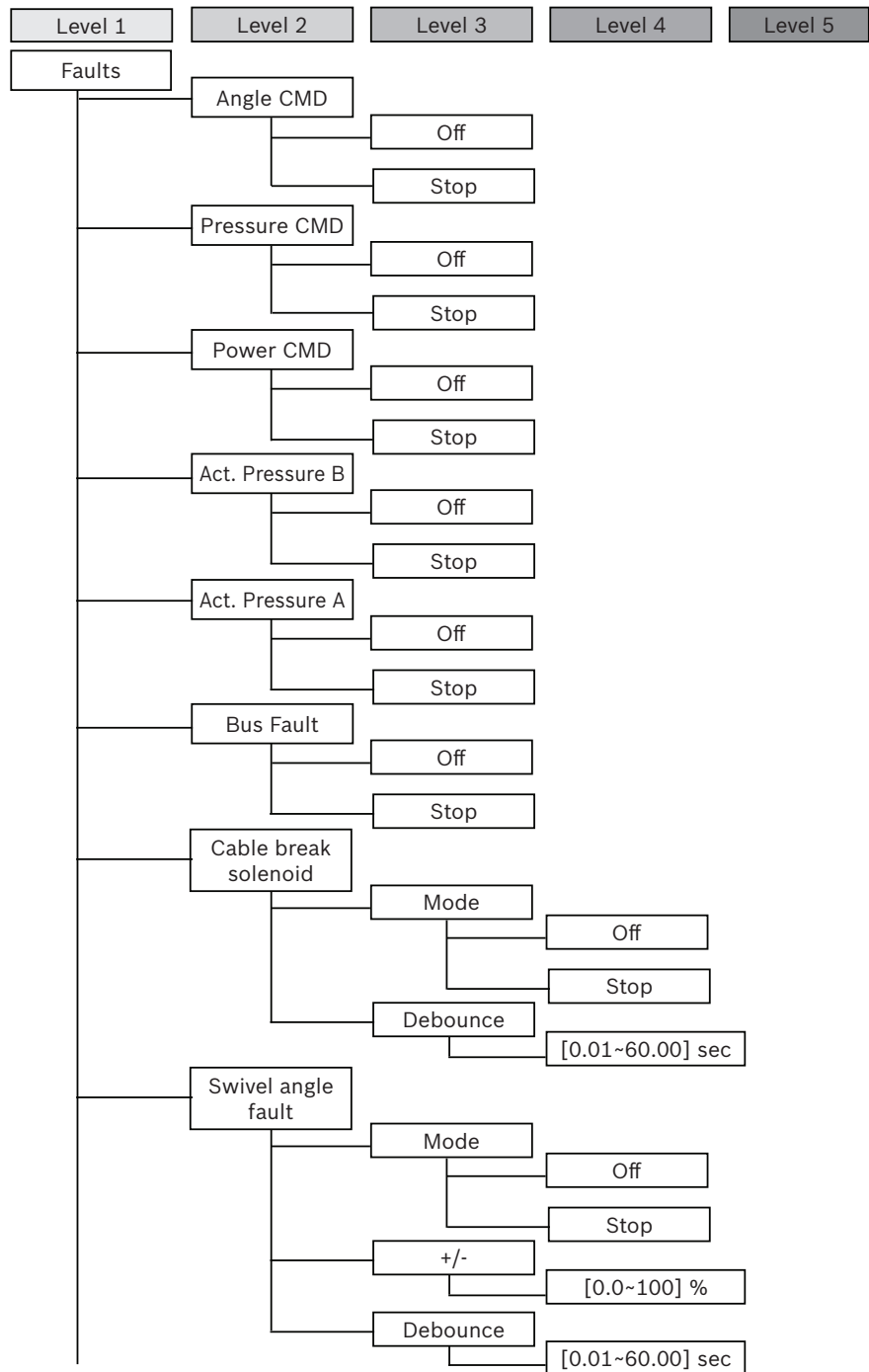

Fig. 26: Menu tree "Faults"

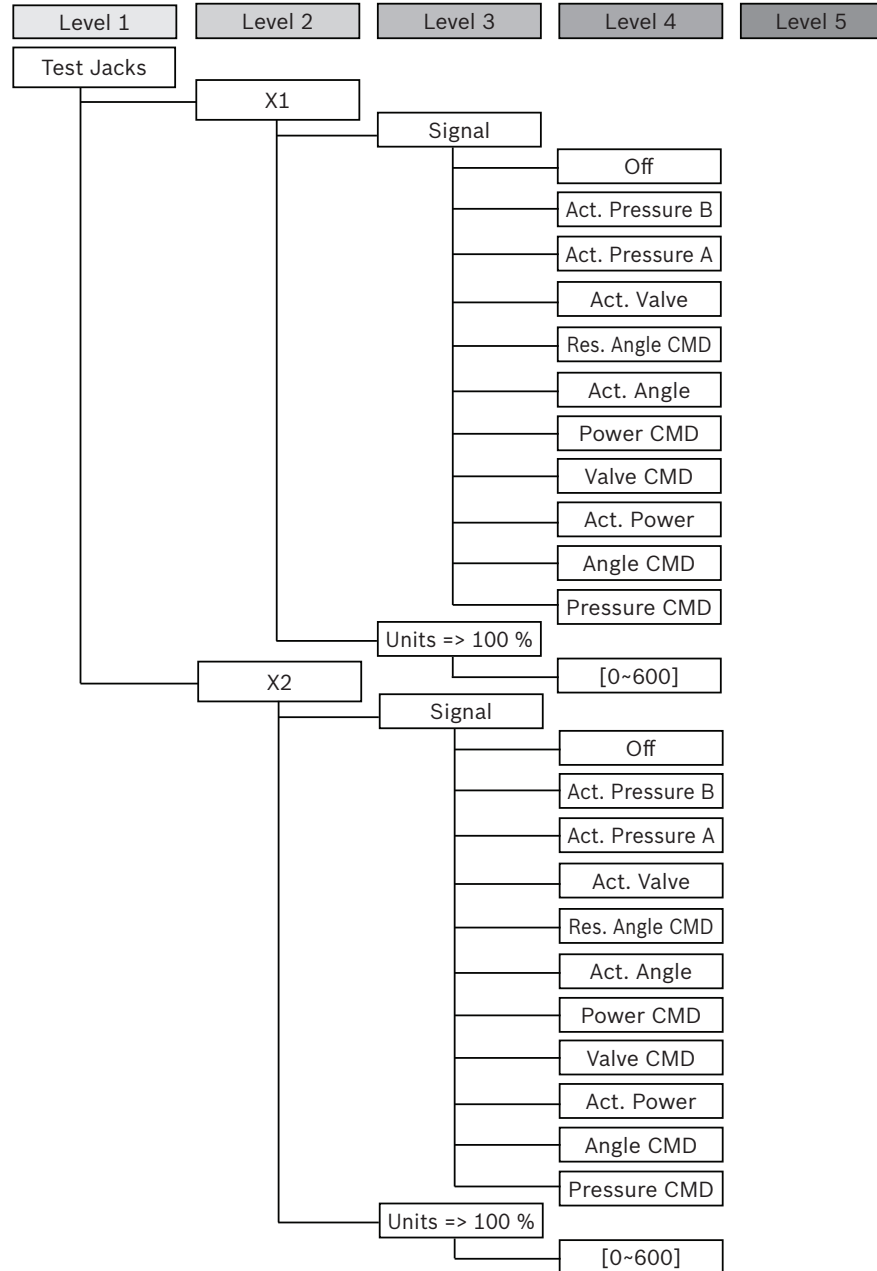

Fig. 27: Menu tree “Test jacks“

9.2 Operating the control electronics VT-VPCD

To make operations directly on the control electronics you can use the four control keys “UP”, “DOWN”, “ENT” and “ESC”.

With the help of these control keys you can quickly and easily check, modify or optimize parameters and settings on the control electronics.



(Initial) commissioning must always be carried out using the BODAC software.

Before changing any parameters or settings, make yourself familiar with the menu structure of your control electronics. Please read the preceding Chapter 9.1.1 “Menu tree for setup and parameters“ on page 39.

Meaning of control keys:

- UP** Use the “UP” key to move upwards within the available menu items at the selected level.
- DOWN** Use the “DOWN” key to move downwards within the available menu items at the selected level.
- ENT** Function for changing the control electronics mode:
Hold the “ENT” control key down for more than 2 seconds to change to the configuration mode “EDIT Parameters”.
Configuration level function:
The “ENT” control key brings you to the next lower level in the menu structure or confirms any values entered.
New values entered will only be stored in the memory after you returned to level 0 (display of the manufacturer’s name)!
- ESC** The “ESC” control key brings you one level up in the menu structure.
- ENT + ESC** To open the configuration menu, press the key combination “ENT” and “ESC”.
The configuration mode is structured by levels. The first level contains the various main terms, under which further sub-headings and setting options are grouped together. Depending on the selection options, a main term can contain up to 4 sub-levels.

The following graphic illustrates the interrelationships of the menu levels.

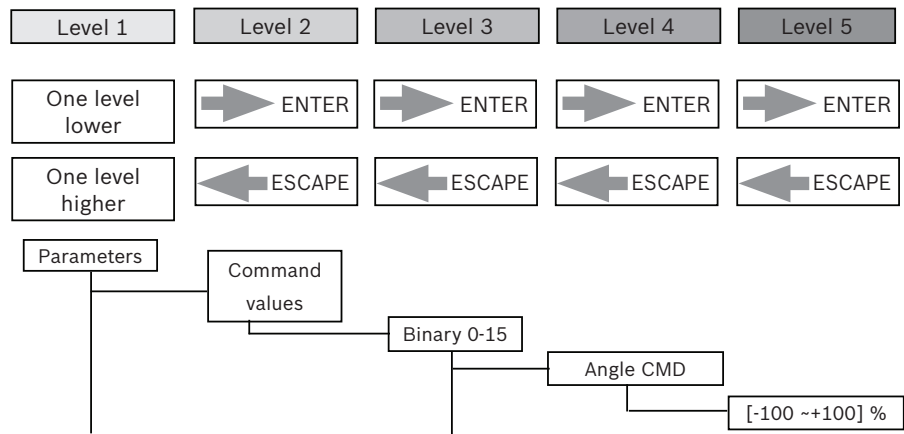

Fig. 28: Examples of menu levels in the configuration mode

How to change from the operation mode to the configuration mode “EDIT Parameters”:

Precondition: You are in the operation mode.

The display shows as running text the manufacturer’s name and the version number of the control electronics or a text determined individually by you.

- ▶ Press the “Enter” control key and hold it depressed (for at least 2 seconds) until “EDIT Parameters” is shown on the display of the control electronics.

The control electronics is in the configuration mode “EDIT Parameters”.

How to change from the operation mode to the configuration mode:

Precondition: You are in the operation mode.

The display shows as running text the manufacturer’s name and the version number of the control electronics or a text determined individually by you.

- ▶ Press the control keys “ENT” and “ESC” simultaneously (exception: for “EDIT Parameters“, see above) and hold them down (for at least 2 seconds) until “Setup” is shown on the display of the control electronics.

The control electronics is now in the setup mode.

How to exit the configuration mode:

In the present example, the second level of the menu tree “Setup” was selected.

The display of the control electronics shows “Sprache/Language” as running text.

- ▶ Press the “ESC” control key.

The display shows “Setup” as running text.

- ▶ Press the control key “ESC”.

The display shows as running text the manufacturer’s name and the version number of the control electronics or a text determined individually by you.



If no entry is made within a minute in the configuration mode, the control electronics automatically changes to the next higher level until the operation mode is reached.

The control electronics VT-VPCD is fully operable in the configuration mode.

How to change a parameter with the help of the control keys:

CAUTION! Uncontrolled system behavior! When parameters are changed with the help of the control keys of the control electronics, the entries are not checked for the signal “enable active”.

- ▶ Do not change one or several analog inputs from voltage to current or from current to voltage. When you change the type of one or several analog inputs, the active value is not interpreted as desired.

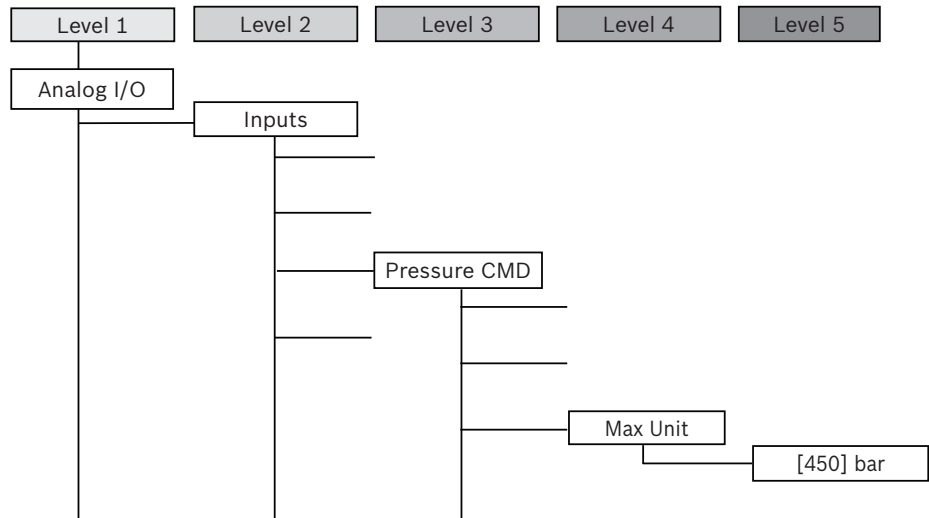

Fig. 29: Configuration example

The menu tree “Parameters” was selected in this example.

5. Press the control keys “ENT” and “ESC” simultaneously and hold them down (for at least 2 seconds) until “Setup” is shown on the display of the control electronics.

The control electronics is now in the configuration mode.

6. Use the control key “UP” or “DOWN” to navigate to menu item “Analog I/O”.
7. Press the control key “ENT”.

The control electronics is now at the second level of the configuration menu “Analog I/O”.

8. Use the control key “UP” or “DOWN” to navigate to the menu item “Inputs”.
9. Press the control key “ENT”.
10. Use the control key “UP” or “DOWN” to navigate to the menu item “Pressure CMD”.
11. Press the control key “ENT”.
12. Use the control key “UP” or “DOWN” to navigate to the menu item “Max Unit”.
13. Press the control key “ENT”.

The value currently set is displayed.

14. Press control key “UP”. This will create a positive sign. To create a negative sign, press the “DOWN” key.
15. Press the “UP” control key repeatedly until “4” appears on the display.
16. Press the control key “ENT”.
17. Press the “UP” control key repeatedly until “5” appears on the display.
18. Press the control key “ENT”.
19. Press the “UP” control key repeatedly until “0” appears on the display.
20. Press the control key “ENT”.
21. Press the “UP” control key repeatedly until “.” appears on the display.
22. Press control key “ENT”.
23. Press the “UP” control key repeatedly until “0” appears on the display.
24. Press the control key “ENT”.

25. Press the “UP” control key repeatedly, until “0” appears on the display.
26. Press the control key “ENT”.

The parameter “Max Unit” 450 bar is shown on the display and is now set.

27. Exit the configuration menu by pressing the “ESC” control key five times.

9.3 Performing diagnostics

9.3.1 Diagnostic options on control electronics VT-VPCD

The diagnostic test jacks on the front panel of the control electronics VT-VPCD (see Chapter 9.1 “Indicator/operating elements and ports of the control electronics“ on page 39) provide two analog outputs with the following ratings:

- X1, 10 Volt for test equipment having $R_i = 100 \text{ k}\Omega$
- X2, 10 Volt for test equipment having $R_i = 100 \text{ k}\Omega$
- COM, ground

Diagnostics terminal



Diagnostics test jack X1 diagnostics test jack X2

Here, you can select the signal to be measured. The following signals can be output: Pressure command value, swivel angle command value, power command value, actual valve value, actual pressure value and actual swivel angle value.

Display (indication of responses in the event of a fault)

With the help of the BODAC software you can determine the response of the connected actuators (drives, etc.) in the “Error” screen during initial commissioning. When the control electronics detects an error, which was determined in the BODAC software, the error will be signaled on the display of the control electronics VT-VPCD.

After the control electronics detected an error defined in the BODAC software, please proceed as follows:

The letter combination “FAIL” will flash on the display of the control electronics!

- ▶ Press the “ENT” key to have the error message shown on the display and eliminate the error.

The procedure for determining the response in the event of an error is described in the online help.

9.3.2 Diagnostics options using BODAC with WinView

The BODAC software features further, detailed diagnostics options.

The “Motion Data” screen and the “Status” screen provide you with an overview of the current state of the control electronics and connected sensors and actuators. For diagnostics, recording and visualization purposes, BODAC operates in conjunction with the visualization software WinView. The required data are acquired in the controls of Bosch Rexroth. The user program hands the data over to WinView, which represents them in a graphic form. The data can be saved in the specific file format .GRA and re-loaded as required. If the necessary WinView version is already installed on your PC, BODAC will integrate it automatically. Otherwise, you are prompted by BODAC to install WinView. You can download WinView free of charge on the Rexroth website

www.boschrexroth.com/hacd.

Motion Data screen

The “Motion Data” screen shows the current signal processing of the control electronics. This provides a quick overview of the current state of process data. The Motion Data display works in conjunction with the visualization software WinView.

Status screen The “Status” window shows the status of the signals currently present. A subdivision is made by “OK”, WARNING” or “ERROR”.
For further information on the Motion Data screen and the Status screen, please refer to the online help.

10 Maintenance and repair

10.1 Cleaning and care

NOTICE

Ingress of dirt and humidity!

Malfunction, loss of function and short-circuit!

- ▶ Observe strictest cleanliness when carrying out any work on the control electronics VT-VPCD.
- ▶ Use only dry and dust-free cloth for cleaning.

10.2 Maintenance

In the interest of a long service life and operational reliability include the following activities for the control electronics in your maintenance schedule:

- Inspect all terminal connections for correct connection and damage at least once a year.
- Inspect all cables for rupture or squashing.
- Replace or have defective or damaged control electronics replaced immediately.

10.3 Repair

The control electronics VT-VPCD can only be replaced as a complete unit.

Unauthorized modifications of the VT-VPCD are not permitted for safety reasons.

Repair work may only be carried out by Bosch Rexroth AG. For repairs, return the device to the service address given in Chapter 15.

11 Removal and replacement

11.1 Preparing the removal

NOTICE

Removal carried out improperly!

The control electronics may be destroyed!

- ▶ Decommission the entire system as described in the general instructions for the system.
- ▶ Disconnect the control electronics and all connected components from the power supply.

11.2 Removal

Loosen the two mounting screws on the front panel and take the control electronics from the plug-in connection without applying any force.

11.3 Preparing components for storage/further use

To prepare the VT-VPCD for storage or further use, proceed as follows:

- ▶ Whenever possible, use the original packaging for storage or use another, suitable ESD packaging and observe ESD regulations.
- ▶ Adhere to the permitted storage temperature range, which is specified in RE 30028.
- ▶ Protect the control electronics against dust and humidity.

12 Disposal

12.1 Environmental protection

Careless disposal of the VT-VPCD and the packaging material could lead to pollution of the environment.

- ▶ Therefore, dispose of the VT-VPCD and the packaging material in accordance with the currently applicable regulations in your country and provide for recycling whenever possible.

13 Extension and conversion

The control electronics VT-VPCD must neither be extended nor converted. Converting the VT-VPCD renders the warranty void.

14 Troubleshooting

14.1 How to proceed for troubleshooting

Always act systematically and targeted, even under pressure of time. Random and imprudent disassembly and readjustment of settings might result in the inability to ascertain the original cause of fault.

- First obtain a general overview of how your product works in conjunction with the entire system.
- Try to clarify whether the product worked properly in conjunction with the entire system before the troubles occurred.
- Try to determine any changes of the entire system in which the product is integrated:
 - Were there any changes to the product’s operating conditions or operating range?
 - Were any changes made or repairs carried out on the complete system (machine/system, electrics, control) or on the product? If yes, which?
 - Was the product or machine used as intended?
 - How did the malfunction manifest itself?
 - Try to get a clear idea of the error cause. Directly ask the (machine) operator.

If you cannot rectify the error, contact one of the contact addresses which can be found at: www.boschrexroth.com/adressen or in the address directory in the Annex.

14.2 Error messages

Table 12: Description of error messages

Error message	Description
±10 V reference	Reference voltage +10 V (b32) or reference voltage -10 V (b30) outside the permitted range.
Power 24	Supply voltage UB (z30) less than UB min.
DO1~DO7 short-circuit	Short-circuit of one or several of the 8 discrete outputs.
Checksum Flash	Checksum error in the program or data memory (flash)
RAM Fault	Error in RAM
Version error	Versions of the individual program parts are not compatible (can occur only after a firmware update was executed).
Angle CMD	The level at analog input “swivel angle command value” b14/16 (AI4) is outside the valid signal range.
Res. Angle CMD	The level at analog input “swivel angle command value” b2/ (AI3) is outside the valid signal range.
Pressure CMD	The level at analog input “pressure command value” b10/12 (AI1) is outside the valid signal range.
Power CMD	The level at analog input “power command value” b18/20 (AI5) is outside the valid signal range.
Pressure Side A	The level at analog input “actual pressure A” b6/8 (AI2) is outside the valid signal range.
Pressure side B	The level at analog input “actual pressure B” b22/24 (AI6) is outside the valid signal range.
LVDT1 Fault 1	Cable break in the secondary branch of the valve position transducer (z14, z16)

Error message	Description
LVDT1 Fault 2	Short-circuit in the supply of the valve position transducer (z18)
LVDT1 Fault 3	Cable break in the supply of the valve position transducer (z18, z12) or short-circuit in the reference potential of the supply (z12)
LVDT2 Fault 1	Cable break in the secondary branch of the pump swivel angle transducer (f22, f24)
LVDT2 Fault 2	Short-circuit in the supply of the pump swivel angle transducer (f26)
LVDT2 Fault 3	Cable break in the supply of the pump swivel angle transducer (f26, f20) or short-circuit in the reference potential of the supply (f20)
Short Cir. Sol a+b	Short-circuit in the connection of solenoid a (z2, z4) or solenoid b (z6, z8)
Bus Fault	Profibus: The slave has left the state "DATA_EXCHANGE". CANopen: The node has left the state "OPERATIONAL". DeviceNet: The node has left the state "ONLINE".

14.3 Changing the fuse

The control electronics is protected against overvoltage by means of a fuse. The fuse is a single-use fuse with the following data:

- F / 4 A / 250 V

The fuse can be blown for two reasons:

1. Blowing can be traced back to material fatigue or a product defect.
 - ▶ In this case, replace the fuse with a new one of the above-mentioned type.
2. The fuse is blown due to external effects, i.e. components or parts connected to the control electronics.
 - ▶ In this case, carry out a diagnosis and remedy the fault that caused the fuse to blow.

Only then should a new fuse be installed.

How to replace the fuse of the control electronics VT-VPCD:

1. Remove the VT-VPCD control electronics from the card holder (reverse of the procedure described in Chapter 7.5 „Installing the VT-VPCD“ on page 30).
2. Gently remove the fuse from the fuse holder without applying any force. See Figure below.

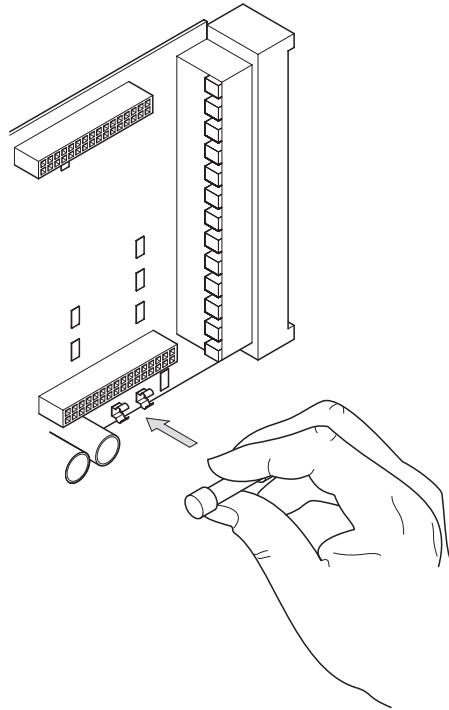

Fig. 30: Fuse of control electronics VT-VPCD

3. Test the fuse using a suitable test device (continuity test).
4. If the fuse is defective, replace it with a new one of the same type.
5. Reinstall control electronics VT-VPCD and perform a functional test.

15 Technical data

The technical data can be found in data sheet RE 30028.

16 Annex

16.1 Address directory

16.1.1 Contact for repairs

Bosch Rexroth AG
Service Industriehydraulik
Bgm.-Dr.-Nebel-Str. 8
97816 Lohr am Main
Germany

Phone +49 (93 52) 40 50 60
<http://www.boschrexroth.com/service>
e-mail: repair.hydraulics@boschrexroth.de

16.1.2 Contact for support

Bosch Rexroth AG
Zum Eisengießer 1
97816 Lohr am Main
Germany

e-mail: support.hacd@boschrexroth.com

16.2 Ordering address

Headquarters:
Bosch Rexroth AG
Zum Eisengießer 1
97816 Lohr am Main
Germany
Phone +49 (93 52) 18-0

The addresses of individual sales organizations can be found on the Internet at
<http://www.boschrexroth.com/addresses>

17 Alphabetical index

▶ A		Installation	30
Abbreviations	7	– local bus	32
Accessories	30	Installation conditions	30
		Intended use	8
▶ B		▶ K	
Block circuit diagrams	20	Keys	23
▶ C		▶ L	
Circuit variant pressure sensorics		LEDs	23
– voltage	18	LEDs inputs/outputs	25
– voltage and bus communication	19	▶ M	
Closed circuit	15	Maintenance	51
Commissioning	37	Menu tree	
Connection		– “Analog I/O“	42
– pressure transducer	35	– “Faults“	45
– solenoids of the proportional valve	32	– “Parameters“	40
– swivel angle transducer	33	– “Setup“	41
– valve position transducer	33	– “Test jacks“	46
▶ D		▶ O	
Diagnostics	50	Open circuit	15
Display	24	Operation	39
Display and operating elements and test sockets	23	▶ P	
Disposal	52	Performance description	14
▶ E		Personnel qualifications	8
Edge connector		Pressure transducer	
– pinout	25	– connection	35
Environmental protection	52	Product description	14
Error messages	53	Profibus interface	24
Extension	52	Pump combinations	16
▶ F		▶ Q	
Fuse		Qualification	8
– change	54	▶ R	
▶ G		Removal	52
General instructions	9	Repair	51
General notes on damage to material and the product	12	Replacement	52
▶ I		▶ S	
Identification of the product	28	Safety instructions	8
Improper use	8	– general	9
		– product-specific	10

Scope of delivery	13
Serial interface	24
Sign of display value	24
Software BODAC	
– installation	37
– system requirements	37
Storage	28
Swivel angle transducer	
– connection	33
Symbols	7
▶ T	
Technical data	55
Terms used	7
Test sockets	25
Tools	29
Transport	28
Troubleshooting	53
▶ U	
Unpacking	29
▶ W	
WinView	50

Bosch Rexroth AG

Zum Eisengießer 1
97816 Lohr a. Main
Germany
Tel. +49 (0) 9352 18-0
info@boschrexroth.de
www.boschrexroth.com