

Digital controller assembly HNC100-SEK for the secondary control of axial piston units

RE 30162/08.11
Replaces: 04.11

1/20

Type SYHNC100-SEK

Component series 3X

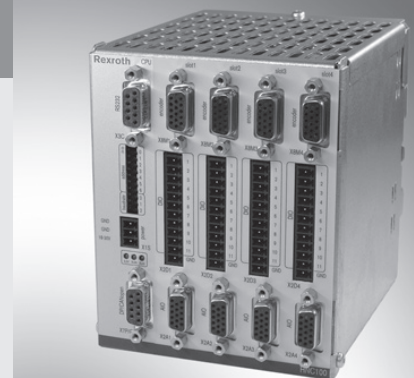

TB102

Table of contents

Content	Page
Features	2
Ordering code	3
Software functionality	4
Overview of the controller functions	4
System overview	5
Block diagram	6
Technical data	7 and 8
Pinout (2-axis version)	9 to 11
Pinout (4-axis version)	12 to 16
Unit dimensions	17
Project planning / Maintenance instructions / Additional information	18 and 19

Features

The VT-HNC100-SEK digital controller assembly is suitable for the closed-loop speed control, the closed-loop torque control as well as the open-loop torque control of axial piston units Type A4VS..DS1(E) with secondary control.

It comprises interfaces for recording the swivel angle position of individual or tandem units as well as for the speed feedback with incremental encoders. The software contains closed-loop control, open-loop control and monitoring functions especially designed for the secondary control.

- Parameterization and process visualization with commercially available PC via serial interface
- Two modules with monitoring function for analyzing the signals from inductive swivel angle sensors
- Analog differential inputs (voltage or current)
- Up to 2 incremental or SSI inputs with monitoring function for the speed or rotary angle sensing

- 1 analog output ± 10 V per I/O card (slot 3 and 4)
- 2 analog outputs ± 10 V per LVDT card (slot 1 and 2)
- Digital inputs
- Profibus DP or CANopen for the communication with SPS
- Digital outputs (switching outputs)
- Configurable sequence routine for switch-on/switch-off order with signal output for isolator valve and a brake that might be available
- Monitoring functions with output of error codes for a better diagnosis

Note regarding the system structure:

In a secondary unit with servo valve 4WS2EM10 (standard version, see data sheet 92056), you moreover need an amplifier module VT 11021 (see data sheet 29743).

Assembly

- Top hat rail 35 mm

Ordering code

SYHNC100-SEK-3X / -00/S000	
SYHNC100 = Serial unit	Software option
Version for secondary control = SEK	S000 ¹⁾ = Without
Number of secondary units = 2 = 4	Hardware option
Component series 30 to 39 (30 to 39: Unchanged technical data and pinout) = 3X	00 = No fitting
	Position transducer ²⁾
	A = 2 x LVDT + 1 x Incremental/SSI (standard)
	D = 4 x LVDT + 2 x Incremental/SSI (standard)
	Bus connection
	P = PROFIBUS DP
	C = CANopen

¹⁾ Software functionality according to description on page 4

²⁾ With 2 secondary units, „A“ has to be selected;
with 4 secondary units, „D“ has to be selected.

Standard types

Type	Material number
SYHNC100-SEK-2-3X/C-A-00/S000	R901293741
SYHNC100-SEK-2-3X/P-A-00/S000	R901293742
SYHNC100-SEK-4-3X/C-D-00/S000	R901267896
SYHNC100-SEK-4-3X/P-D-00/S000	R901278028

Included within the scope of delivery:

Mating connector for

- X1S (Type Phoenix Mini Combicon 3-pole)
- X2D (Type Phoenix Mini Combicon 12-pole)
- X2A (Type HD-SUB 15-pole)
- X8M (Type HD-SUB 15-pole)

Recommended accessories (can be ordered separately)

Description	Material number
Interface cable RS232 (1:1), length 3 m	R900776897
USB-RS232 converter	R901066684
Cable set VT17220-1X/HNC100-3X, length 2m, for analog signals (connection X2A) and digital position measurement systems (connection X8M) with HD connector and open breakout cable for SYHNC100-SEK-3X	R901189300
Plug-in connector Type 6ES7972-0BA41-0XA0 for PROFIBUS DP	R900050152

Software functionality

Software functionality

- Basically, the software contains the closed-loop control types closed-loop speed control, closed-loop torque control and open-loop torque control. It is possible to switch between the closed-loop control types during operation in a shock-free form.
- Adjustable ramp functions for speed and torque command value allow for an adjustment of external command values
- Software-based monitoring functions with parameterizable switching thresholds as well as hardware error messages analyzed by software
- Underlying closed-control loops per LVDT card for two swivel angle controllers
- Sequence program with defined signal sequence for switching a unit on and off
- Configuration, parameterization and diagnosis of an application by means of the WIN-PED PC program
- System-specific software extensions can be prepared upon request

PC program WIN-PED

For SYHNC100-SEK, only the version “WIN-PED 6.6” is used. It can be downloaded on the Internet from www.boschrexroth.de/hnc100.

Related enquiries: support.nc-systems@boschrexroth.de

System requirements:

- IBM PC or compatible system
- Windows XP or Windows 7
- Random access memory (512 MB recommended)
- 100 MB free hard disk capacity

Note:

The “WIN-PED 6.6” PC program is **not** included in delivery. It can be downloaded in the Internet free of charge!

Download in the Internet: www.boschrexroth.com/hnc100

Inquiries: support.nc-systems@boschrexroth.de

Overview of the controller functions

- Swivel angle controller
- Speed controller
- Closed-loop torque control
- Open-loop torque control

Monitoring functions:

- Cable break monitoring for incremental and SSI encoder
- Cable break monitoring for swivel angle transducers
- Acceleration too high
- Overspeed (max. speed)
- Speed difference command / actual
- Swivel angle difference command / actual

System overview (example)

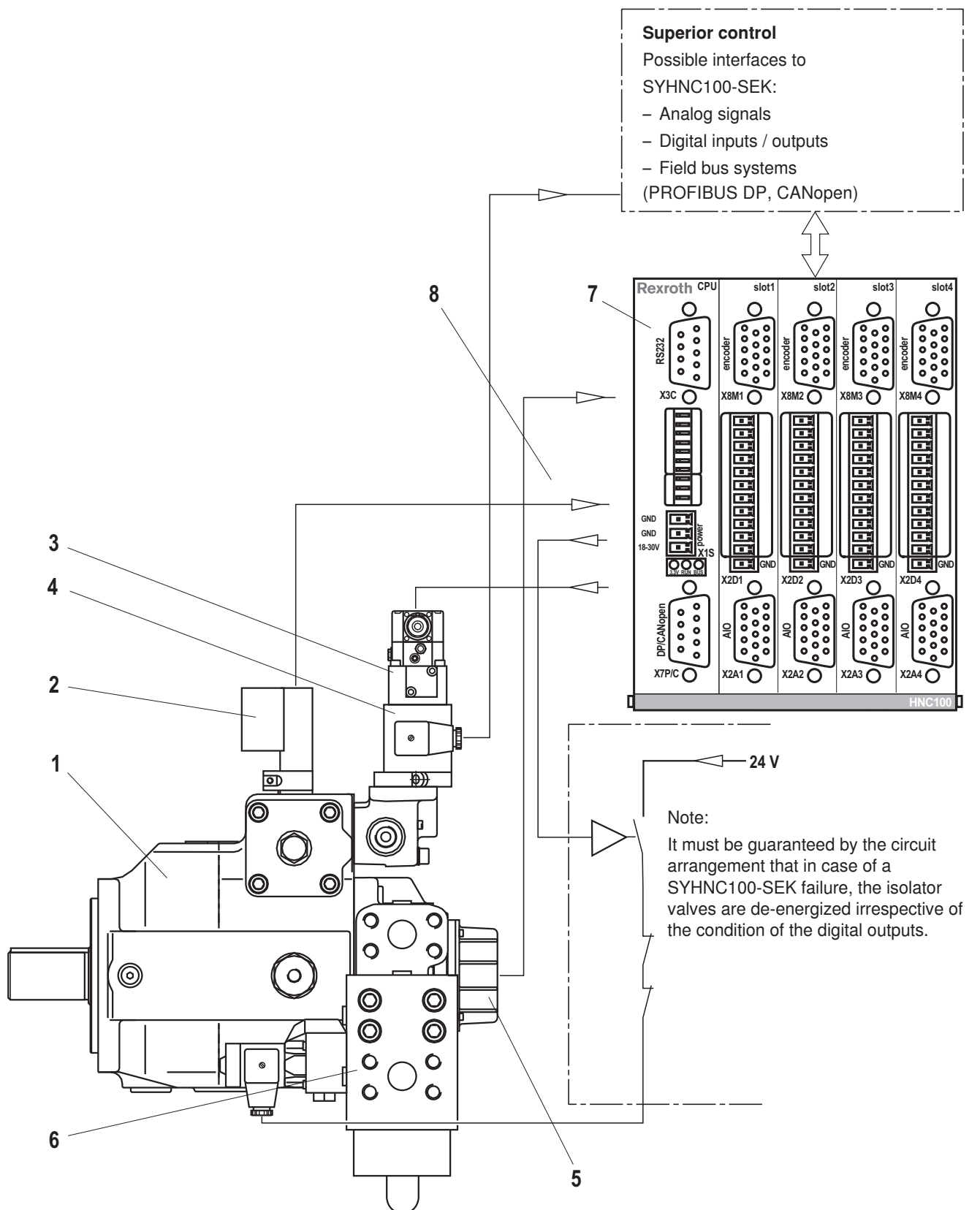

- 1 Secondary unit A4VS...
- 2 Swivel angle position transducer IW9 or AWX
- 3 Actuation of the servo valve by amplifier VT 11021
- 4 Sandwich plate filter

- 5 Incremental or SSI encoder
- 6 Electrically unlockable check valve (isolator valve)
- 7 SYHNC100-SEK
- 8 Connection cable

Block diagram (example with 2 drives)

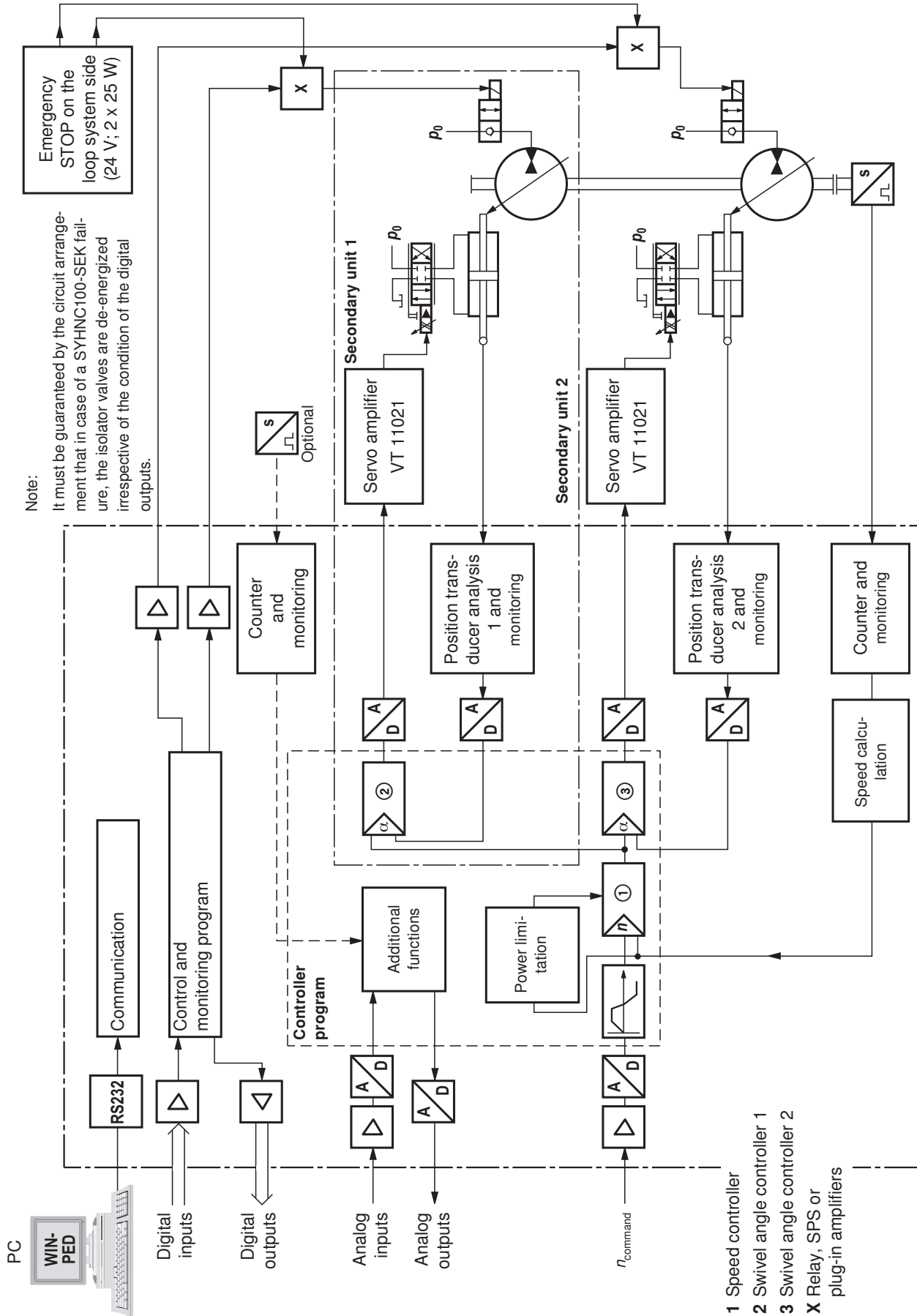

Technical data

Operating voltage ¹⁾	U_B	18 to 30 VDC, residual ripple < 1.5 V _{pp}
Current consumption at 24 VDC		1 to 4 A (depending on the HNC variant and the additionally supplied components)
Processor		32 bit power PC
Analog inputs (AI) per axis electronics:		
– Voltage inputs (differential inputs)		
• Channel number		2
• Input voltage	U_E	max +12 V or –12 V (+10 V to –10 V measurable)
• Input resistance	R_E	200 kΩ ± 5 %
• Resolution		5 mV
• Non-linearity		< ±0,25 %
• Calibration tolerance		max. 40 mV (with factory settings)
– Current inputs		
• Channel number		2
• Input current	I_E	4 mA to 20 mA
• Input resistance	R_E	350 Ω at 20° (100 Ω measuring resistance)
• Leakage current	I_V	0.1 to 0.4 %
• Resolution		5 μA
– Voltage supply for analog sensors via SYHNC100-SEK		
	U	U_B at X2A1 to X2A4, Pin 14 (+24 Vsens)
Analog outputs (AO) per axis electronics:		
– with 4 drives		
		2 analog outputs each at X2A1 and X2A2 1 analog output each at X2A3 and X2A4
– with 2 drives		
		2 analog outputs at X2A1 1 analog output at X2A2
– Non-linearity		
• In the range –9.5 V to +9.5 V		< 0.1 %
• In the range –10 V to –9.5 V and +9.5 V to +10 V		< 0.2 %
– Voltage output		
• Output voltage	U_{nom}	–10 V to +10 V (max. –10.7 V to +10.7 V)
• Output current	I_{max}	±10 mA
• Load	R_{min}	1 kΩ
• Residual ripple		±60 mV (without noise)
• Resolution		1.25 mV
– Current output		
• Output current	I_{nom}	4 mA to 20 mA
• Load	R_{max}	500 Ω
• Resolution		0.625 μA

¹⁾ If a 24 V transducer supply is implemented directly via the SYHNC100-SEK (supply voltage is looped in), the transducer specification has to be observed.

Technical data (continued)

Interface for WIN-PED 6		RS232
Bus interface		PROFIBUS DP (max. 12 MBaud according to IEC 61158), CANopen
Gate inputs (DI) or outputs (DO) per axis electronics (settable via software)	Quantity	11 ¹⁾
Gate inputs (DI)	Logic level	log 0 (low) ≤ 5 V; log 1 (high) ≥ 10 V to U_B , $I_e = 20$ mA at $U_B = 24$ V
	Port	Flexible conductor up to 1.5 mm ²
Gate outputs (DO)	Logic level	log 0 (low) ≤ 2 V; log 1 (high) $\leq U_B$; $I_{max} = 20$ mA, Maximum load capacity C = 0.047 μ F
	Port	Flexible conductor up to 1.5 mm ²
Reference potential for all signals		DGND
Digital position transducers (encoder) per axis electronics:		
– Incremental transducer (transducer with TTL output)		
• Input voltage	log 0	0 to 1 V
	log 1	2.8 to 5.5 V
• Input current	log 0	–0.8 mA (with 0 V)
	log 1	0.8 mA (with 5 V)
• Max. frequency referring to Ua1	f_{max}	250 kHz
• Voltage supply for incremental encoders via the HNC	U, I	5.25 V \pm 1 %, max. 400 mA total current across all axes at X8M3 to X8M4, pin 12 (+5 Venc)
– SSI transducer (Due to the higher control quality, an SSI transducer with clock synchronization should be used.)		
• Coding		Gray-Code
• Data width		Adjustable up to max. 28 Bit
• Line receiver / line driver		RS485
• Voltage supply for SSI encoders via SYHNC100-SEK	U	U_B at X8M3 to X8M4, Pin 14 (+24 Venc)
Reference potential for all signals		EGND
Reference voltage per axis electronics	U_{ref}	+10 V \pm 25 mV (20 mA)
Dimensions		See page 18
Assembly		Top hat rail TH 35-7.5 or TH 35-15 according to EN 60715
Admissible operating temperature range	ϑ	0 to 50 °C
Storage temperature range	ϑ	–20 to +70 °C
Protection class according to EN 60529:1991		IP 20
Weight	m	960 g

¹⁾ Maximally, 20 digital outputs can be connected

Note:

Information on the **environment simulation testing** for the areas EMC (electromagnetic compatibility), climate and mechanical load see data sheet 30162-U.

Pinout (2-axis version)

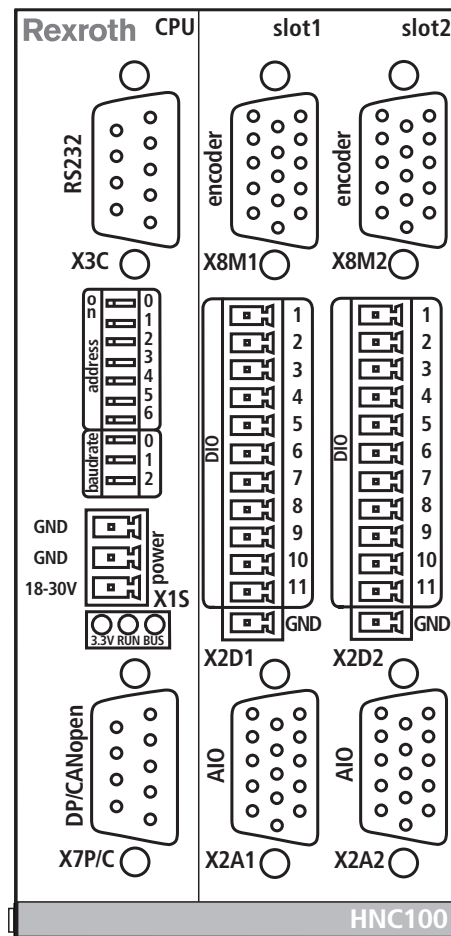

X7C	CANopen
Pin	
1	reserved
2	CAN_L
3	CAN_GND
4	reserved
5	reserved
6	reserved
7	CAN_H
8	reserved
9	reserved

X7P	PROFIBUS DP
Pin	
1	reserved
2	reserved
3	RxD/TxD-P
4	CNTR-P
5	DGND
6	VP
7	reserved
8	RxD/TxD-N
9	reserved

X1S	Power
Pin	
1	GND
2	GND
3	18 – 30 V

X3C	RS232
Pin	
1	LCAN_H
2	TxD
3	RxD
4	reserved
5	GND
6	reserved
7	reserved
8	reserved
9	LCAN_L

Note for all ports:

The pins marked with “**reserved**” are reserved and must not be wired!

Pinout (2-axis version, SLOT1)

SLOT 1 X8M1 - ENCODER LVDT / port IW9 / AWX			
Signal	Pin	Description of IW9	Description of AWX
LVDT1	1	IW9 GND / axis 1	AWX1 Pin 1 / axis 1
LVDT1	2	IW9 Pin 2 / axis 1	AWX1 Pin 2 / axis 1
LVDT1	3	IW9 Pin 1 / axis 1	AWX1 Pin 3 / axis 1
LVDT1	4	Bridge to Pin 5	reserved
LVDT1	5	Bridge to Pin 4	AWX1 Pin 4 / axis 1
	6	reserved	reserved
LVDT2	7	IW9 Pin 1 / axis 2	AWX2 Pin 3 / axis 2
LVDT2	8	Bridge to Pin 9	reserved
LVDT2	9	Bridge to Pin 8	AWX2 Pin 4 / axis 2
	10	reserved	reserved
LVDT2	11	IW9 GND / axis 2	AWX2 Pin 1 / axis 2
	12	reserved	reserved
	13	reserved	reserved
	14	reserved	reserved
LVDT2	15	IW9 Pin 2 / axis 2	AWX2 Pin 2 / axis 2

SLOT 1 X2D1 - digital I/O		
Signal	Pin	Description
OUT 1	1	Ready for operation / axis 1 sum error
OUT 2	2	Ready for operation / axis 2 sum error
OUT 3	3	Axis 1 isolator valve control
OUT 4	4	Axis 2 isolator valve control
OUT 5	5	Open brake
OUT 6	6	Controller active
OUT 7	7	Speed = 0
OUT 8	8	Torque = 0
OUT 9	9	reserved
OUT 10	10	Operating mode "0" = n control "1" = MD open-loop/closed-loop control
OUT 11	11	Swivel angle control active

SLOT 1 X2A1 - analog I/O		
Signal	Pin	Description
Vin 1+	1	Torque command value ± 10 V
Vin 1-	2	Torque command value voltage reference
Vin 2+	3	Actual torque value ± 10 V
Vin 2-	4	Actual torque value voltage reference
Cin 1+	5	reserved
Cin 1-	6	reserved
Cin 2+	7	Actual torque value 4 to 20 mA / load cell
Cin 2-	8	Actual torque value current reference
n.c.	9	reserved
AGND	10	Analog GND
Vout 1	11	Analog OUT1 ± 10 V / actuating variable 1 -> module amplifier
Vout 2	12	Analog OUT2 ± 10 V / actuating variable 2 -> module amplifier
Cout1	13	reserved
+24V	14	24 V output voltage
n.c.	15	reserved

Pinout (2-axis version, SLOT2)

SLOT 2 X8M2 - ENCODER			
Signal	Pin	INK description	SSI description
-B	1	-Ua2 / GEL293 Pin G	
+Clk	2		+ CLK
+R	3	reserved	reserved
-R	4	reserved	reserved
+A	5	+Ua1 / GEL293 Pin C	
-A	6	-Ua1 / GEL293 Pin H	
-Clk	7		- CLK
+B	8	+Ua2 / GEL293 Pin B	
-DATA	9		- Data
GND	10	0 V / GEL293 Pin A	Ground
+DATA	11		+ Data
+5Venc	12	+5 V / GEL293 Pin F	
+10Vref	13	reserved	reserved
+24V enc	14		+24V
	15	reserved	reserved

SLOT 2 X2D2 - digital I/O		
Signal	Pin	Description
IN 1	1	Enable
IN 2	2	Start
IN 3	3	Error reset
IN 4	4	Open-loop torque control
IN 5	5	Closed-loop torque control
IN 6	6	Pressure OK
IN 7	7	Open brake
IN 8	8	reserved
IN 9	9	reserved
IN 10	10	reserved
IN 11	11	Select speed setpoint intern 2

SLOT 2 X2A2 - analog I/O		
Signal	Pin	Description
Vin 1+	1	Speed command value signal ± 10 V
Vin 1-	2	Speed command value reference
Vin 2+	3	Actual pressure value signal 0 to 10 V / pressure cell
Vin 2-	4	Actual pressure value reference
Cin 1+	5	reserved
Cin 1-	6	reserved
Cin 2+	7	Actual pressure value current signal 0 to 20 mA / pressure cell
Cin 2-	8	Actual pressure value current reference
n.c.	9	reserved
AGND	10	AGND
Vout 1	11	Diagnosis 1
Vout 2	12	Diagnosis 2
Cout1	13	reserved
+24V	14	24 V output voltage
n.c.	15	reserved

Pinout (4-axis version)

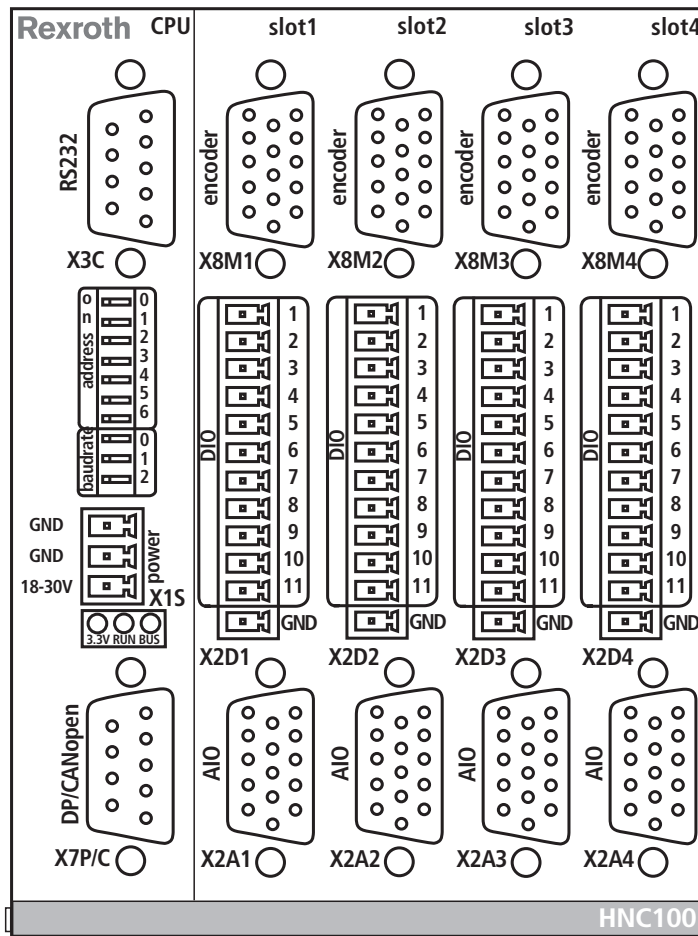

X7C CANopen	
Pin	
1	reserved
2	CAN_L
3	CAN_GND
4	reserved
5	reserved
6	reserved
7	CAN_H
8	reserved
9	reserved

X7P PROFIBUS DP	
Pin	
1	reserved
2	reserved
3	RxD/TxD-P
4	CNTR-P
5	DGND
6	VP
7	reserved
8	RxD/TxD-N
9	reserved

X1S Power	
Pin	
1	GND
2	GND
3	18 – 30 V

X3C RS232	
Pin	
1	LCAN_H
2	TxD
3	RxD
4	reserved
5	GND
6	reserved
7	reserved
8	reserved
9	LCAN_L

Note for all ports:

The pins marked with “**reserved**” are reserved and must not be wired!

Pinout (4-axis version, SLOT1)

SLOT 1 X8M1 - ENCODER LVDT / port IW9 / AWX			
Signal	Pin	Description of IW9	Description of AWX
LVDT1	1	IW9 GND / axis 1	AWX1 Pin 1 / axis 1
LVDT1	2	IW9 Pin 2 / axis 1	AWX1 Pin 2 / axis 1
LVDT1	3	IW9 Pin 1 / axis 1	AWX1 Pin 3 / axis 1
LVDT1	4	Bridge to Pin 5	reserved
LVDT1	5	Bridge to Pin 4	AWX1 Pin 4 / axis 1
	6	reserved	reserved
LVDT2	7	IW9 Pin 1 / axis 2	AWX2 Pin 3 / axis 2
LVDT2	8	Bridge to Pin 9	reserved
LVDT2	9	Bridge to Pin 8	AWX2 Pin 4 / axis 2
	10	reserved	reserved
LVDT2	11	IW9 GND / axis 2	AWX2 Pin 1 / axis 2
	12	reserved	reserved
	13	reserved	reserved
	14	reserved	reserved
LVDT2	15	IW9 Pin 2 / axis 2	AWX2 Pin 2 / axis 2

SLOT 1 X2D1 - digital I/O		
Signal	Pin	Description
OUT 1	1	Ready for operation / axis 1 sum error
OUT 2	2	Ready for operation / axis 2 sum error
OUT 3	3	Axis 1 isolator valve control
OUT 4	4	Axis 2 isolator valve control
OUT 5	5	Open brake
OUT 6	6	Controller active
OUT 7	7	Speed = 0
OUT 8	8	Torque = 0
OUT 9	9	reserved
OUT 10	10	Operating mode "0" = n control "1" = MD open-loop/closed-loop control
OUT 11	11	Swivel angle control active

SLOT 1 X2A1 - analog I/O		
Signal	Pin	Description
Vin 1+	1	Torque command value ± 10 V
Vin 1-	2	Torque command value voltage reference
Vin 2+	3	Actual torque value ± 10 V
Vin 2-	4	Actual torque value voltage reference
Cin 1+	5	reserved
Cin 1-	6	reserved
Cin 2+	7	Actual torque value 4 to 20 mA / load cell
Cin 2-	8	Actual torque value current reference
n.c.	9	reserved
AGND	10	Analog GND
Vout 1	11	Analog OUT1 ± 10 V / actuating variable 1 -> module amplifier
Vout 2	12	Analog OUT2 ± 10 V / actuating variable 2 -> module amplifier
Cout1	13	Analog OUT1 ± 20 mA
+24V	14	24 V output voltage
n.c.	15	reserved

Pinout (4-axis version, SLOT2)

SLOT 2 X8M2 - ENCODER LVDT / port IW9 / AWX			
Signal	Pin	Description of IW9	Description of AWX
LVDT1	1	IW9 GND / axis 3	AWX1 Pin 1 / axis 3
LVDT1	2	IW9 Pin 2 / axis 3	AWX1 Pin 2 / axis 3
LVDT1	3	IW9 Pin 1 / axis 3	AWX1 Pin 3 / axis 3
LVDT1	4	Bridge to Pin 5	reserved
LVDT1	5	Bridge to Pin 4	AWX1 Pin 4 / axis 3
	6	reserved	reserved
LVDT2	7	IW9 Pin 1 / axis 4	AWX2 Pin 3 / axis 4
LVDT2	8	Bridge to Pin 9	reserved
LVDT2	9	Bridge to Pin 8	AWX2 Pin 4 / axis 4
	10	reserved	reserved
LVDT2	11	IW9 GND / axis 4	AWX2 Pin 1 / axis 4
	12	reserved	reserved
	13	reserved	reserved
	14	reserved	reserved
LVDT2	15	IW9 Pin 2 / axis 4	AWX2 Pin 2 / axis 4

SLOT 2 X2D2 - digital I/O		
Signal	Pin	Description
OUT 1	1	Ready for operation / axis 3 sum error
OUT 2	2	Ready for operation / axis 4 sum error
OUT 3	3	Axis 3 isolator valve control
OUT 4	4	Axis 4 isolator valve control
OUT 5	5	reserved
OUT 6	6	reserved
OUT 7	7	reserved
OUT 8	8	reserved
OUT 9	9	reserved
OUT 10	10	reserved
OUT 11	11	reserved

SLOT 2 X2A2 - analog I/O		
Signal	Pin	Description
Vin 1+	1	reserved
Vin 1-	2	reserved
Vin 2+	3	reserved
Vin 2-	4	reserved
Cin 1+	5	reserved
Cin 1-	6	reserved
Cin 2+	7	reserved
Cin 2-	8	reserved
n.c.	9	reserved
AGND	10	AGND
Vout 1	11	Analog OUT3 ± 10 V / actuating variable 3 -> module amplifier
Vout 2	12	Analog OUT4 ± 10 V / actuating variable 4 -> module amplifier
Cout1	13	reserved
+24V	14	24 V output voltage
n.c.	15	reserved

Pinout (4-axis version, SLOT3)

SLOT 3 X8M3 - ENCODER			
Signal	Pin	INK description	SSI description
-B	1	-Ua2 / GEL293 Pin G	
+Clk	2		+ CLK
+R	3	reserved	reserved
-R	4	reserved	reserved
+A	5	+Ua1 / GEL293 Pin C	
-A	6	-Ua1 / GEL293 Pin H	
-Clk	7		- CLK
+B	8	+Ua2 / GEL293 Pin B	
-DATA	9		- Data
GND	10	0 V / GEL293 Pin A	Ground
+DATA	11		+ Data
+5Venc	12	+5 V / GEL293 Pin F	
+10Vref	13	reserved	reserved
+24V enc	14		+24V
	15	reserved	reserved

SLOT 3 X2D3 - digital I/O		
Signal	Pin	Description
IN 1	1	Enable
IN 2	2	Start
IN 3	3	Error reset
IN 4	4	Open-loop torque control
IN 5	5	Closed-loop torque control
IN 6	6	Pressure OK
IN 7	7	Open brake
IN 8	8	reserved
IN 9	9	reserved
IN 10	10	reserved
IN 11	11	Select speed setpoint intern 2

SLOT 3 X2A3 - analog I/O		
Signal	Pin	Description
Vin 1+	1	Speed command value signal ± 10 V
Vin 1-	2	Speed command value reference
Vin 2+	3	Actual pressure value signal 0 to 10 V / pressure cell
Vin 2-	4	Actual pressure value reference
Cin 1+	5	reserved
Cin 1-	6	reserved
Cin 2+	7	Actual pressure value current signal 0 to 20 mA / pressure cell
Cin 2-	8	Actual pressure value current reference
n.c.	9	reserved
AGND	10	AGND
Vout 1	11	Diagnosis 1
Vout 2	12	reserved
Cout1	13	reserved
+24V	14	24 V output voltage
n.c.	15	reserved

Pinout (4-axis version, SLOT4)

SLOT 4 X8M4 - ENCODER INK2			
Signal	Pin	INK description	SSI description
-B	1	-Ua2 / GEL293 Pin G	
+Clk	2		+ CLK
+R	3	reserved	reserved
-R	4	reserved	reserved
+A	5	+Ua1 / GEL293 Pin C	
-A	6	-Ua1 / GEL293 Pin H	
-Clk	7		- CLK
+B	8	+Ua2 / GEL293 Pin B	
-DATA	9		- Data
GND	10	0 V / GEL293 Pin A	Ground
+DATA	11		+ Data
+5Venc	12	+5 V / GEL293 Pin F	
+10Vref	13	reserved	reserved
+24V enc	14		+24V
	15	reserved	reserved

SLOT 4 X2D4 - digital I/O		
Signal	Pin	Description
IN 1	1	reserved
IN 2	2	reserved
IN 3	3	reserved
IN 4	4	reserved
IN 5	5	reserved
IN 6	6	reserved
IN 7	7	reserved
IN 8	8	reserved
IN 9	9	reserved
IN 10	10	reserved
IN 11	11	reserved

SLOT 4 X2A4 - analog I/O		
Signal	Pin	Description
Vin 1+	1	reserved
Vin 1-	2	reserved
Vin 2+	3	reserved
Vin 2-	4	reserved
Cin 1+	5	reserved
Cin 1-	6	reserved
Cin 2+	7	reserved
Cin 2-	8	reserved
n.c.	9	reserved
AGND	10	AGND
Vout 1	11	Diagnosis 2
Vout 2	12	reserved
Cout1	13	reserved
+24V	14	24 V output voltage
n.c.	15	reserved

Unit dimensions (dimensions in mm)

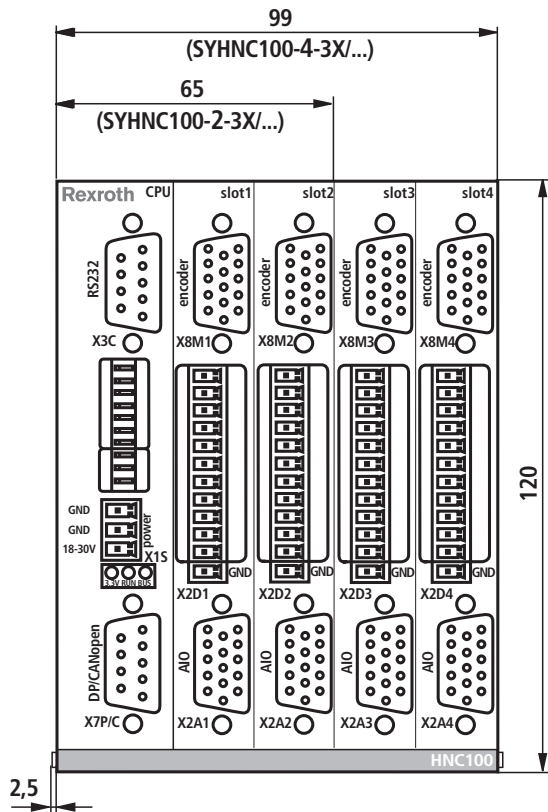

Installation on top hat rail TH 35-7.5 or TH 35-15 according to EN 60715

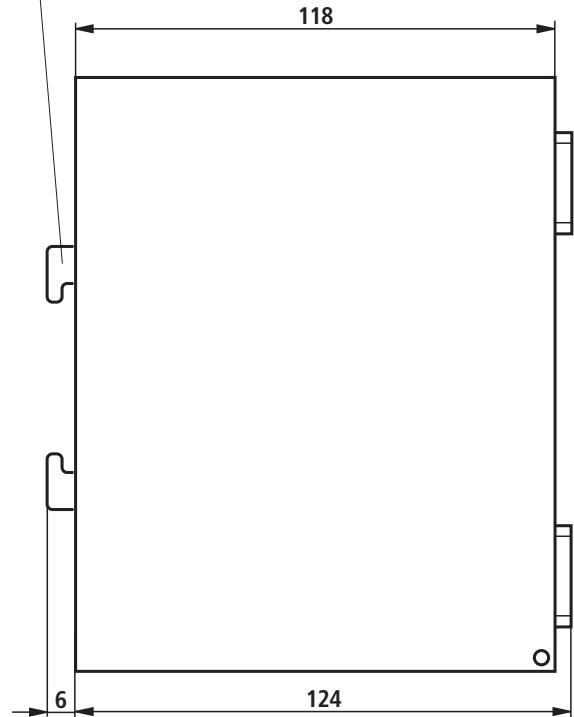

Project Planning / Maintenance Instructions / Additional Information

Product documentation for SYHNC100-SEK

Data sheet 30162

Operating instructions 30162-B

Software description 30162-01-Z

Declaration on environmental compatibility 30162-U

WIN-PED 6

General Information on the maintenance and commissioning of hydraulic components
07800 / 07900

Commissioning software and documentation on the Internet: www.boschrexroth.com/HNC100

Maintenance instructions:

- The devices have been tested in the plant and are supplied with default settings.
- Only complete units can be repaired. The repaired units will be supplied with default settings. User-specific settings are not maintained. The operator will have to re-transfer the corresponding user parameters and programs.

Notes:

- Electric signals taken out via control electronics (e.g. signal “No error”) may not be used for the actuation of safety-relevant machine functions! (See also the European standard “Safety requirements for fluid power systems and their components - Hydraulics”, EN 982.)
- If electromagnetic interference must be expected, take appropriate measures to safeguard the function (depending on the application, e.g. screening, filtration)!
- For further notes see operating instructions 30162-B

Project Planning / Maintenance Instructions / Additional Information

Installation position

Don't install the SYHNC100-SEK next to power electronics (e.g. frequency converters); the power supply unit of the SYHNC100-SEK should be installed as close to the SYHNC100-SEK as possible.

Voltage supply

Keep the connection as short as possible, lay forward and return conductor (+24 V / GND) together.

When supplying an inductive position transducer via the interface of the SYHNC100-SEK, the provided voltage must comply with the required data of the position transducer.

Earthing of the housing

The necessary earthing of the SYHNC100-SEK housing is effected by connecting the mounting bolts with the control cabinet's rear panel.

Screening

Use only cables with a shield of copper braiding for signal lines. Usually, connect one side of the shield with the SYHNC100-SEK side. Connect the cable shield extensively with the metallized connector housing (push back the shield and clamp it under the pull relief).

Wiring

- Largest possible spatial separation of signal and load lines
- Don't lead signal lines through strong magnetic fields
- Pass signal lines without interruptions
- Twist load lines (e.g. voltage supply) passed as two individual wires
- Don't pass the signal lines parallelly to load lines

System interference suppression

- Switched inductivities:
 - DC → Antiparallel free-wheeling diode via actuator winding
 - AC → Type-related R/C combination via actuator winding
- Electric motors:
 - Lead the R/C combinations of each motor winding to earth
- Frequency converter:
 - Provide an input filter in the voltage supply of the frequency converter
 - Pass control lines of the motor in a shielded form and separate from other lines and/or provide an output filter for motor lines
 - Extensive contact of the frequency converter housing with the rear panel of the control cabinet

Notes

Bosch Rexroth AG
Hydraulics
Zum Eisengießer 1
97816 Lohr am Main, Germany
Phone +49 (0) 93 52 / 18-0
Fax +49 (0) 93 52 / 18-23 58
documentation@boschrexroth.de
www.boschrexroth.de

© This document, as well as the data, specifications and other information set forth in it, are the exclusive property of Bosch Rexroth AG. It may not be reproduced or given to third parties without its consent. The data specified above only serve to describe the product. No statements concerning a certain condition or suitability for a certain application can be derived from our information. The information given does not release the user from the obligation of own judgment and verification. It must be remembered that our products are subject to a natural process of wear and aging.