

Control devices HM, HS5 and EO series 1x and 30



- ▶ The control devices for the axial piston variable pumps A4VSO, A4VBO, A4VSG and A4CSG
- ▶ Open and closed circuits

Features

- ▶ Electro-hydraulic control with proportional- and control valve
- ▶ Digital electro-hydraulic control systems with amplifier or on-board electronics and IntraWorks freely programmable operating software (HS5 and HS5E)
- ▶ Control of swivel angle, pressure and torque limitation (HS5P)
- ▶ Control for speed variability with HS5 and HS5E.
- ▶ Mechanical $V_{g \min}$ and $V_{g \max}$ limitation
- ▶ Electric control for inside-reservoir installation under fluid (HS5M, EO2M)
- ▶ The special version and HS5V enable overcenter and decompression via the pump.
- ▶ HS5(E)V, HS5(E)L with internal control pressure supply as standard

Contents

Type code for A4VSO	2
Type code for A4VBO	3
Type code for A4VSG	4
Type code for A4CSG	5
HM1 / HM2 – Hydraulic control, quantity-dependent	6
HM2C – Customer solution with proportional valve, position transducer	12
HS5(P) – electro-hydraulic control with control valve	16
HS5M – suitable for use under fluid	23
HS5V(P) – control with internal control pressure supply for open circuit	27
HS5L(P) – control with internal control pressure supply for A4CSG	31
HS5E(P) – control system with integrated digital electronics (OBE)	34
Electrical data of pilot control valve HS5E	38
XH4: Signals and pin assignment of the central connector	39
HS5EV(P) – control supply with integrated digital electronics (OBE) and internal control pressure supply	45
HS5EL(P) – control with internal control pressure supply for A4CSG	51
HS5(E)K / EO1K / EO2K – short circuit valve	53
HS5(E)Z(P) – Zero swivel function with (de-energized) control valve for A4VSG and A4CSG	58
EO1 / EO2 – control with proportional valve	61
EO2M – Suitable for use under fluid	70
Project planning notes	74
Installation instructions	74
Safety instructions	75
Related documentation	76

Type code for A4VSO

01	02	03	04	05	06	07	08	09	10	11	12
	A4VS(L)	O		/			-				

Hydraulic fluid

01	For details see data sheet 92050
----	----------------------------------

Axial piston unit

02	Swashplate design, variable	A4VS(L)¹⁾
----	-----------------------------	-----------------------------

Operating mode

03	Pump, open circuit (see data sheet 92050)	O
----	---	----------

Size (NG)

04	Geometric displacement V_g [cm ³]	40	71	125	180	250	355	500	750	1000
----	---	-----------	-----------	------------	------------	------------	------------	------------	------------	-------------

Control device

		40	71	125	180	250	355	500	750	1000	
05	Hydraulic control, depending on quantity										
	minimum control pressure 20 bar	●	●	●	-	●	-	-	-	-	HM1
	minimum control pressure 50/100/125 bar	●	●	●	●	●	●	●	●	●	HM2
	Customer compact solution: electro-hydraulic control with proportional valve and with AWAX - position transducer (prepared for customer-specific control system)	○	○	●	○	●	○	●	○	○	HM2C
	Digital, electro-hydraulic control, with control valve for electric displacement and pressure and torque limitation with VT-HPC-1-1X with external control pressure supply. For variable-speed drives (Sytronix), please order the required SD card separately, see (data sheet 30237)	●	●	●	●	●	●	●	●	●	HS5²⁾
and with pressure transducer HM20-2X/630-C-K35	●	●	●	●	●	●	●	●	●	HS5P²⁾
suitable for use under fluid	●	●	●	●	●	●	●	●	●	HS5M²⁾
with internal control pressure supply	●	●	●	●	●	●	-	-	-	HS5V²⁾
and with pressure transducer HM20-2X/630-C-K35	●	●	●	●	●	●	-	-	-	HS5VP²⁾
	Digital electro-hydraulic control system, with control valve with OBE for electric displacement and pressure control and torque limitation with external control pressure supply	●	●	●	●	●	●	●	●	●	HS5E²⁾
and with pressure transducer HM20-2X/630-C-K35	●	●	●	●	●	●	●	●	●	HS5EP²⁾
with internal control pressure supply	●	●	●	●	●	●	-	-	-	HS5EV²⁾
and with pressure transducer HM20-2X/630-C-K35	●	●	●	●	●	●	-	-	-	HS5EVP²⁾
	Analog, electro-hydraulic control, with proportional valve for electric displacement control with VT 5035-1X										
....minimum control pressure 20 bar	●	●	●	-	●	-	-	-	-	EO1²⁾	
....minimum control pressure 50/100/125 bar	●	●	●	●	●	●	●	●	●	EO2²⁾	
....suitable for use under fluid	●	●	●	●	●	●	●	●	●	EO2M	

Series

		40	71	125	180	250	355	500	750	1000	
06	Series 1, index 0	●	●	-	-	-	-	-	-	-	10
	Series 3, index 0	-	-	●	●	●	●	●	●	●	30

Further details on positions 07 to 12 can be found in data sheet 92050

● = Available ○ = On request - = Not available

1) Charge pump (L) only available with NG 750

2) Operation with HF hydraulic fluids on request

Type code for A4VBO

01	02	03	04	05	06	07	08	09	10	11	12
		O			/		-				

Rotary group version

01	For details see data sheet 92122
----	----------------------------------

Axial piston unit

		71	125	250	450	
02	Swashplate design, variable, high-pressure unit up to 450 bar (see data sheet 92122)	●	●	●	●	A4VB

Operating mode

03	Pump, open circuit	O
----	--------------------	----------

Size (NG)

04	Geometric displacement V_g [cm ³]	71	125	250	450
----	---	-----------	------------	------------	------------

Control device

		71	125	250	450	
05	Customer compact solution: electro-hydraulic control with proportional valve and with AWAX position transducer (prepared for customer-specific control system)	○	○	○	○	HM2C
	Digital, electro-hydraulic control, with control valve for electric displacement and pressure and torque limitation with VT-HPC-1-1X with external control pressure supply	●	●	●	●	HS5¹⁾
	...and with pressure transducer HM20-2X/630-C-K35	●	●	●	●	HS5P¹⁾
	...suitable for use under fluid	●	●	●	●	HS5M¹⁾
	...with internal control pressure supply	●	●	●	-	HS5V¹⁾
	...and with pressure transducer HM20-2X/630-C-K35	●	●	●	-	HS5VP¹⁾
	Digital electro-hydraulic control system, with control valve with OBE for electric displacement and pressure control and torque limitation with external control pressure supply	●	●	●	●	HS5E¹⁾
	...and with pressure transducer HM20-2X/630-C-K35	●	●	●	●	HS5EP¹⁾
	...with internal control pressure supply	●	●	●	-	HS5EV¹⁾
	...and with pressure transducer HM20-2X/630-C-K35	●	●	●	-	HS5EVP¹⁾

Series

06	Series 1, index 0	●	-	-	-	10
	Series 3, index 0	-	●	●	●	30

For details see data sheet 92122 (A4VBO)

07	Direction of rotation
08	Sealing material
09	Drive shaft
10	Mounting flange
11	Port plate for working lines
12	Through drive

● = Available ○ = On request - = Not available ▲ = Not for new projects

1) Operation with HF hydraulic fluids on request

Type code for A4VSG

01	02	03	04	05	06	07	08	09	10	11	12	13	14
	A4VS	G			/		-						

Hydraulic fluid

01	For details see data sheet 92100
----	----------------------------------

Axial piston unit

02	Swashplate design, variable	A4VS
----	-----------------------------	-------------

Operating mode

03	Pump, closed circuit (see data sheet 92100)	G
----	---	----------

Size (NG)

04	Geometric displacement V_g [cm ³]	40	71	125	180	250	355	500	750	1000
----	---	-----------	-----------	------------	------------	------------	------------	------------	------------	-------------

Control device

		40	71	125	180	250	355	500	750	1000		
05	Hydraulic control, depending on quantity											
	minimum control pressure 20 bar	●	●	●	-	●	-	-	-	-	HM1	
	minimum control pressure 50/100/125 bar	●	●	●	●	●	●	●	●	●	HM2	
	Customer compact solution: electro-hydraulic control with proportional valve and with AWAX - position transducer (prepared for customer-specific control system)	○	○	●	○	●	○	●	○	○	HM2C	
	Digital, electro-hydraulic control, with control valve for electric displacement and pressure and torque limitation with VT-HPC-1-1X with external control pressure supply	●	●	●	●	●	●	●	●	●	HS5¹⁾	
with 2 pressure transducers HM20-2X/630-C-K35	●	●	●	●	●	●	●	●	●	HS5P¹⁾	
with short circuit valve	●	●	●	●	●	●	●	●	●	HS5K¹⁾	
with 2 pressure transducers HM20-2X/630-C-K35	●	●	●	●	●	●	●	●	●	HS5KP¹⁾	
suitable for use under fluid	●	●	●	●	●	●	●	●	●	HS5M¹⁾	
with zero swivel function	-	-	-	-	-	-	●	○	○	HS5Z¹⁾	
and 2 pressure transducers HM20-2X/630-C-K35	-	-	-	-	-	-	●	○	○	HS5ZP¹⁾	
	Digital electro-hydraulic control system, with control valve with OBE for electric displacement and pressure control and torque limitation with external control pressure supply	●	●	●	●	●	●	●	●	●	HS5E¹⁾	
with 2 pressure transducers HM20-2X/630-C-K35	●	●	●	●	●	●	●	●	●	HS5EP¹⁾	
with short circuit valve	●	●	●	●	●	●	●	●	●	HS5EK¹⁾	
with 2 pressure transducers HM20-2X/630-C-K35	●	●	●	●	●	●	●	●	●	HS5EKP¹⁾	
with zero swivel function	-	-	-	-	-	-	●	○	○	HS5EZ¹⁾	
and 2 pressure transducers HM20-2X/630-C-K35	-	-	-	-	-	-	●	○	○	HS5EZP¹⁾	
	Analog electro-hydraulic control, with proportional valve for electric displacement control with VT 5035-1X											
minimum control pressure 20 bar	●	●	●	-	●	-	-	-	-	EO1¹⁾	
....and with short circuit valve	●	●	●	-	●	-	-	-	-	EO1K¹⁾		
....minimum control pressure 50/100/125 bar	●	●	●	●	●	●	●	●	●	EO2¹⁾		
....and with short circuit valve	●	●	●	●	●	●	●	●	●	EO2K¹⁾		

For details of positions 06 to 14 see data sheet 92100 (A4VSG)

● = Available ○ = On request - = Not available ▲ = Not for new projects

1) Operation with HF hydraulic fluids on request

Type code for A4CSG

01	02	03	04	05	06	07	08	09	10	11	12	14
A4CS	G		/			-						

Axial piston unit

01	Swashplate design, variable	A4CS
----	-----------------------------	-------------

Operating mode

02	Pump, closed circuit (see data sheet 92105)	G
----	---	----------

Size (NG)

03	Geometric displacement V_g [cm ³]	250	355	500	750
----	---	------------	------------	------------	------------

Control device

		250	355	500	750	
04	Hydraulic control, depending on quantity					
	Customer compact solution: electro-hydraulic control with proportional valve and with AWAX position transducer (prepared for customer-specific control system)	●	○	●	○	HM2C
	Digital, electro-hydraulic control, with control valve for electric displacement and pressure and torque limitation with VT-HPC-1-1X with external control pressure supply For variable-speed drives (Sytronix), please order the required SD card separately, see (data sheet 30237)	●	●	●	●	HS5¹⁾
	...with 2 pressure transducers HM20-2X/630-C-K35	●	●	●	●	HS5P¹⁾
	...with short circuit valve	●	●	●	●	HS5K¹⁾
	...with 2 pressure transducers HM20-2X/630-C-K35	●	●	●	●	HS5KP¹⁾
	...with internal control pressure supply	●	●	●	●	HS5L¹⁾
	...with 2 pressure transducers HM20-2X/630-C-K35	●	●	●	●	HS5LP¹⁾
	...and with zero swivel function	-	-	●	○	HS5Z¹⁾
	...with 2 pressure transducers HM20-2X/630-C-K35	-	-	●	○	HS5ZP¹⁾
	Digital electro-hydraulic control system, with control valve with OBE for electric displacement and pressure control and torque limitation with external control pressure supply	●	●	●	●	HS5E¹⁾
	...with 2 pressure transducers HM20-2X/630-C-K35	●	●	●	●	HS5EP¹⁾
	...with internal control pressure supply	●	●	●	●	HS5EL¹⁾
	...with 2 pressure transducers HM20-2X/630-C-K35	●	●	●	●	HS5ELP¹⁾
	...with short circuit valve	●	●	●	●	HS5EK¹⁾
	...with 2 pressure transducers HM20-2X/630-C-K35	●	●	●	●	HS5EKP¹⁾
	...and with zero swivel function	-	-	●	○	HS5EZ¹⁾
	...with 2 pressure transducers HM20-2X/630-C-K35	-	-	●	○	HS5EZP¹⁾
	Analog electro-hydraulic control, with proportional valve for electric displacement control with VT 5035-1X					
	...minimum control pressure 100/125 bar	●	●	●	●	EO2¹⁾
	...and with short circuit valve	●	●	▲	▲	EO2K¹⁾

For details of positions 05 to 14 see data sheet 92105 (A4CSG)

● = Available ○ = On request - = Not available ▲ = Not for new projects

¹⁾ Operation with HF hydraulic fluids on request

HM1 / HM2 – Hydraulic control, quantity-dependent

Type	NG	40	71	125	180	250	355	500	750	1000	
A4VSO, A4VSG		●	●	●	–	●	–	–	–	–	HM1
A4VSO, A4VSG		●	●	●	●	●	●	●	●	●	HM2

The control **HM1/2** sets the displacement of the pump depending on the control fluid quantity.

This control is used for 2-point circuit or as a base device for controls with proportional valves (additional electric feedback required), e.g. HS5, HS5E, E02, E01.

Spring-centering

The spring-centering of the stroking cylinder is standard. It is used for setting and adjustment in the depressurized neutral position, but without a defined reset during high-pressure operation.

Notes

- ▶ The spring feedback in the controller and pump control spring centering are no safety devices. The controller can stick in an undefined position due to internal contamination (contaminated hydraulic fluid, abrasion or residual contamination from system components). As a result, the flow in the axial piston unit will no longer respond correctly to the operator's specifications. Check whether the application on your machine requires additional safety measures to bring the driven consumer to a safe position (immediate stop).

Swivel angle limitation

Minimum and maximum swivel angle limitation is mechanically adjustable up to 50 % $V_{g \max}$.

For size 500, $V_{g \min}$ is adjustable up to 50 % $V_{g \max}$ and $V_{g \max}$ up to 70 % $V_{g \max}$.

Notes

Setting with A4VSO and A4VBO (open circuit):

- ▶ The $V_{g \max}$ stop is set to nominal $V_{g \max}$ as standard. Please specify different values in your order
- ▶ The $V_{g \min}$ stop is set to $V_g = 0$ l/min with $P_{HD} = 20$ bar as standard. Other values should be specified when placing the order.

Setting with A4VSG and A4CSG (closed circuit):

- ▶ The $V_{g \max}$ stops are set on both sides to nominal $V_{g \max}$.

When ordering, please state other setting requests in plain text.

Two versions are available:

Type	Control pressure [bar]	Sizes
HM1	from 20	40, 71, 125 and 250 (see page 7)
HM2	from 50/100/125	40...1000 (see page 8)

HM2: To minimize the control fluid consumption, the stroking chambers are sealed in sizes 125 to 750.

▼ Flow direction in closed circuit

Direction of rotation		Swiveling range ¹⁾
clockwise	counter-clockwise	
B to A	A to B	clockwise
A to B	B to A	counter-clockwise

Overcenter with A4VSO is available on request.

▼ Flow direction in open circuit

Direction of rotation		Swiveling range ¹⁾
clockwise	counter-clockwise	
S to B		counter-clockwise
	S to B	clockwise

1) See swivel angle indicator

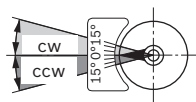

Technical data HM1

Size		NG	40	71	125	250
Control pressure (in X ₁ , X ₂)	p_{min}	bar	20	20	20	20
	p_{max}	bar	100	100	100	100
Control stroke	s_{max}	mm	14.2	17.1	20.7	25.9
Control area	A	cm ²	16.6	24.6	36.3	56.7
Control volume	$V_{S max}$	cm ³	23.6	42.1	75.2	147
Weight: approx. (A4VSO...HM1...N00)	m	kg	38	55	92	194

Circuit diagrams HM1

▼ **Sizes 40 and 71**

Example: open circuit A4VSO

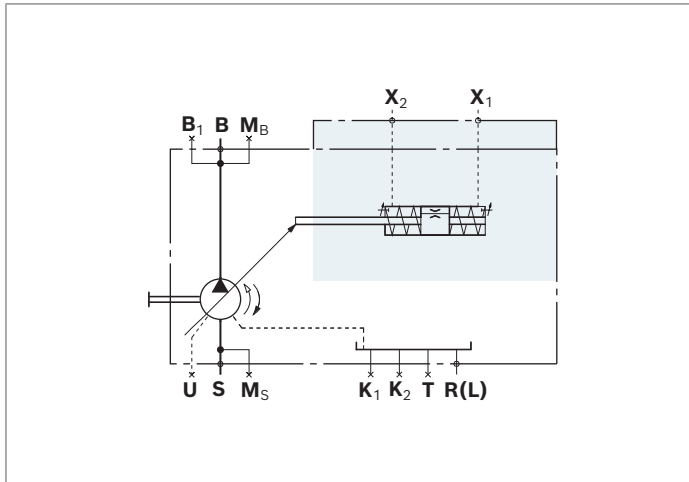

▼ **Sizes 125 and 250**

Example: closed circuit A4VSG

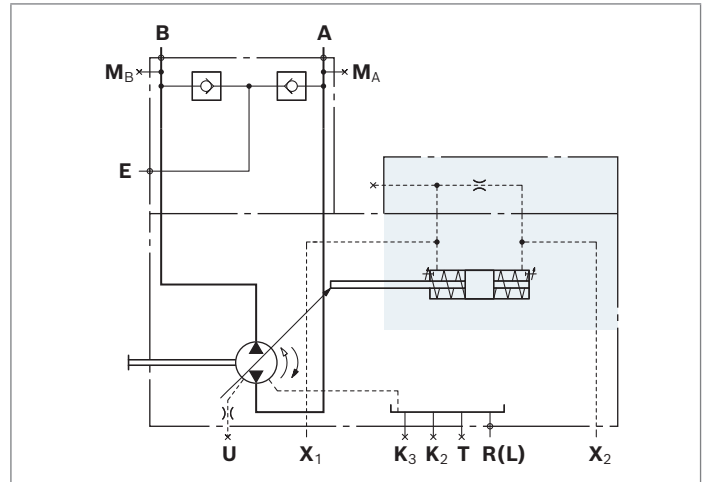

Ports	with swivel direction	
X ₁	Control pressure	counter-clockwise
X ₂	Control pressure	clockwise

Technical data HM2

For A4CSG with HM2, the control pressure relief valve (see data sheet 92105, circuit diagram for version **F** with integrated boost pump) is not required and is replaced with a threaded plug.

To minimize the control fluid consumption, the stroking chambers are sealed in sizes 125...1000 and can be bled via the ports **R₂...R₇**.

Size		NG	40	71	125	180	250	355	500	750	1000
Control pressure (in X₁ , X₂)	p_{min}	bar	50	50	50	100	100	100	125	125	125
	p_{max}	bar	350	350	350	350	350	350	350	350	350
Control stroke	s_{max}	mm	14.2	17.1	20.7	20.7	25.9	25.9	32.6	37.0	41.4
Control area	A	cm ²	8.1	12.6	18.1	18.1	28.3	28.3	38.2	56.8	63.6
Control volume	$V_{S max}$	cm ³	11.4	21.5	37.5	37.5	73.2	73.2	124.5	210	263.3
Weight: approx. (A4VSO...HM2...N00)	m	kg	38	55	92	106	194	214	327	470	600

Circuit diagrams HM2

▼ **Sizes 40 and 71**

Example: open circuit A4VSO

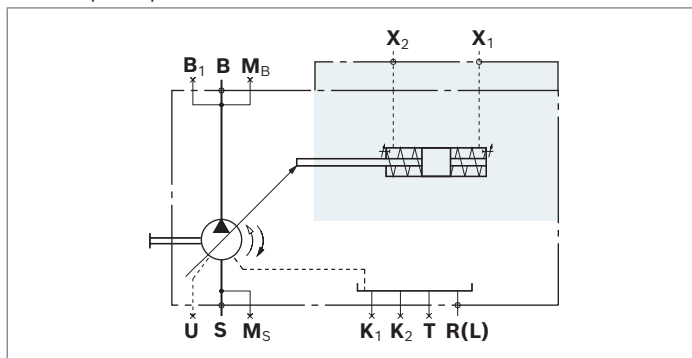

▼ **Sizes 125 to 355**

Example: open circuit A4VSO

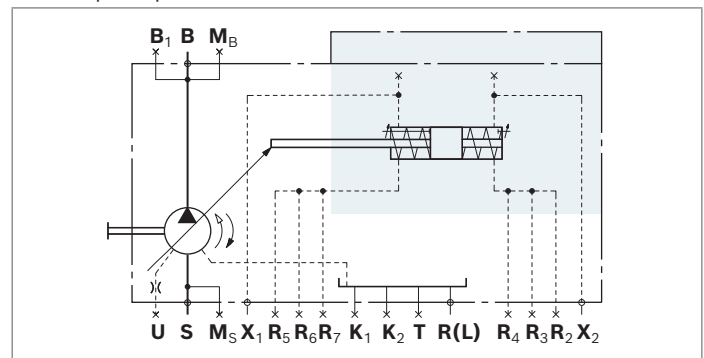

▼ **Sizes 500 to 1000**

Example: closed circuit A4VSG

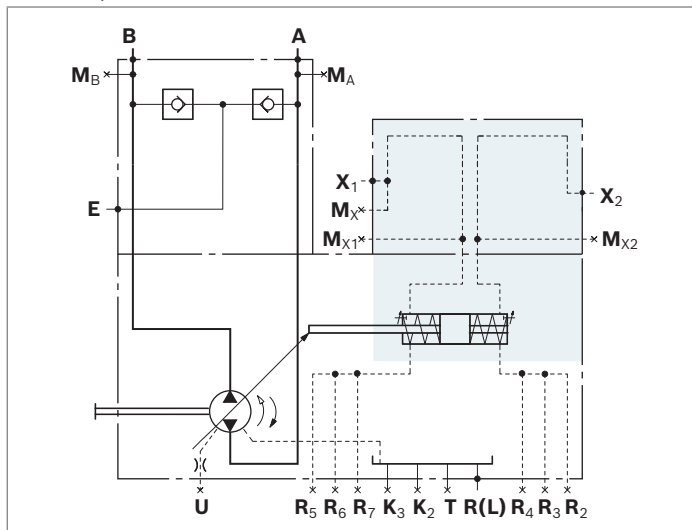

Ports	
X₁	Control pressure
X₂	Control pressure
M_x, M_{x1}, M_{x2}	Measuring ports control pressure
R₂ ... R₇	Air bleeding the stroking chamber

Dimensions HM1/HM2

▼ **A4VSO and A4VSG, size 40 and 71**

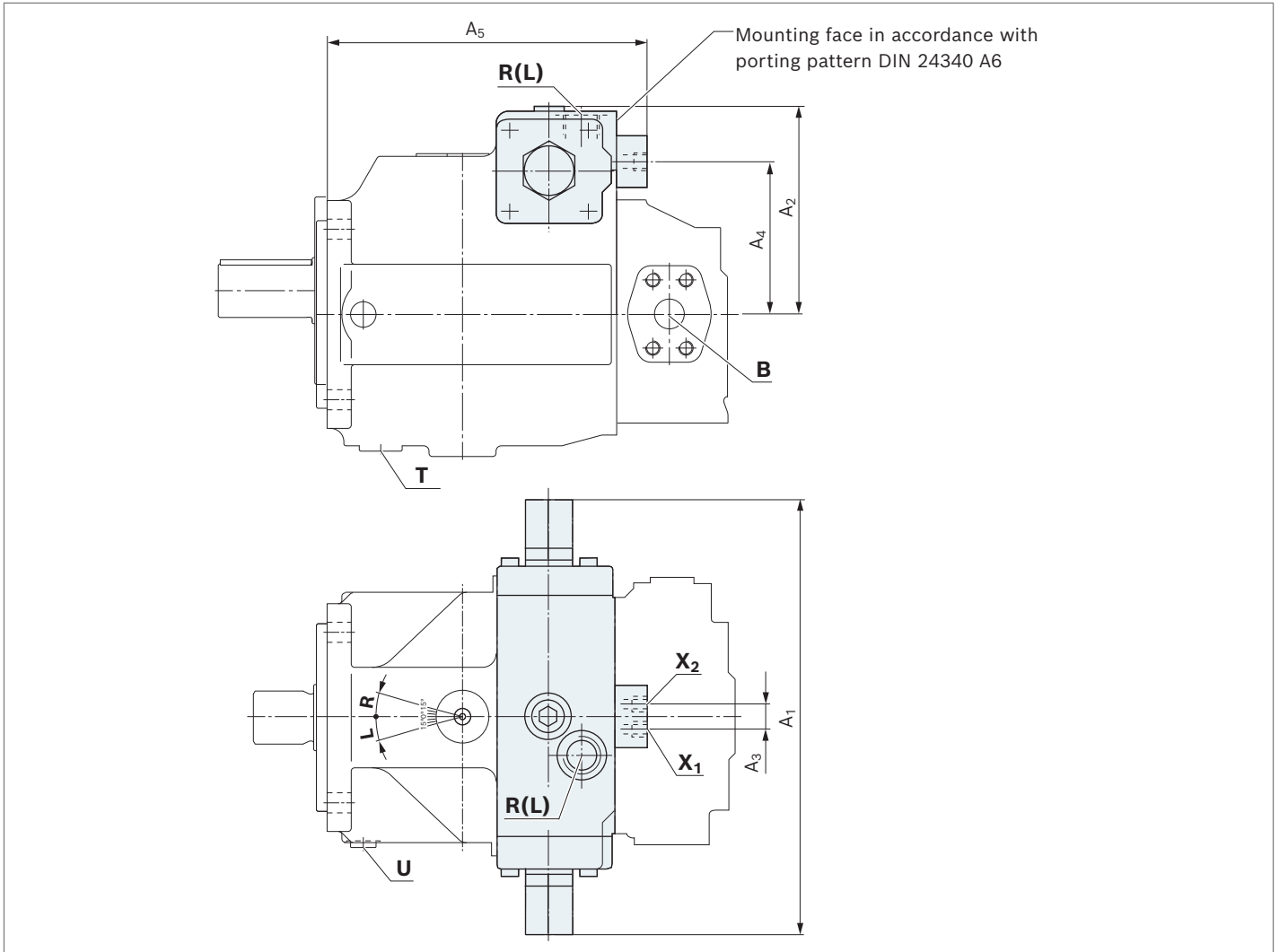

NG	A ₁	A ₂	A ₃	A ₄	A ₅	
40	296	136	24	102	217	For detailed dimensions and technical data for the variable pump, see data sheet 92050 (A4VSO) or 92100 (A4VSG)
71	332	157	28	120	245	

Ports		Standard	Size	p_{max} [bar] ¹⁾	State ²⁾
X ₁ , X ₂	Control pressure	DIN 3852-1	M14 × 1.5; 12 deep	100 (with HM1) 350 (with HM2)	O

1) Depending on the application, momentary pressure peaks can occur. Keep this in mind when selecting measuring devices and fittings.

2) O = Must be connected (plugged on delivery)
 X = Plugged (in normal operation)

Dimensions HM1/HM2

▼ **A4VSO, A4VSG and A4CSG, sizes 125 to 355**

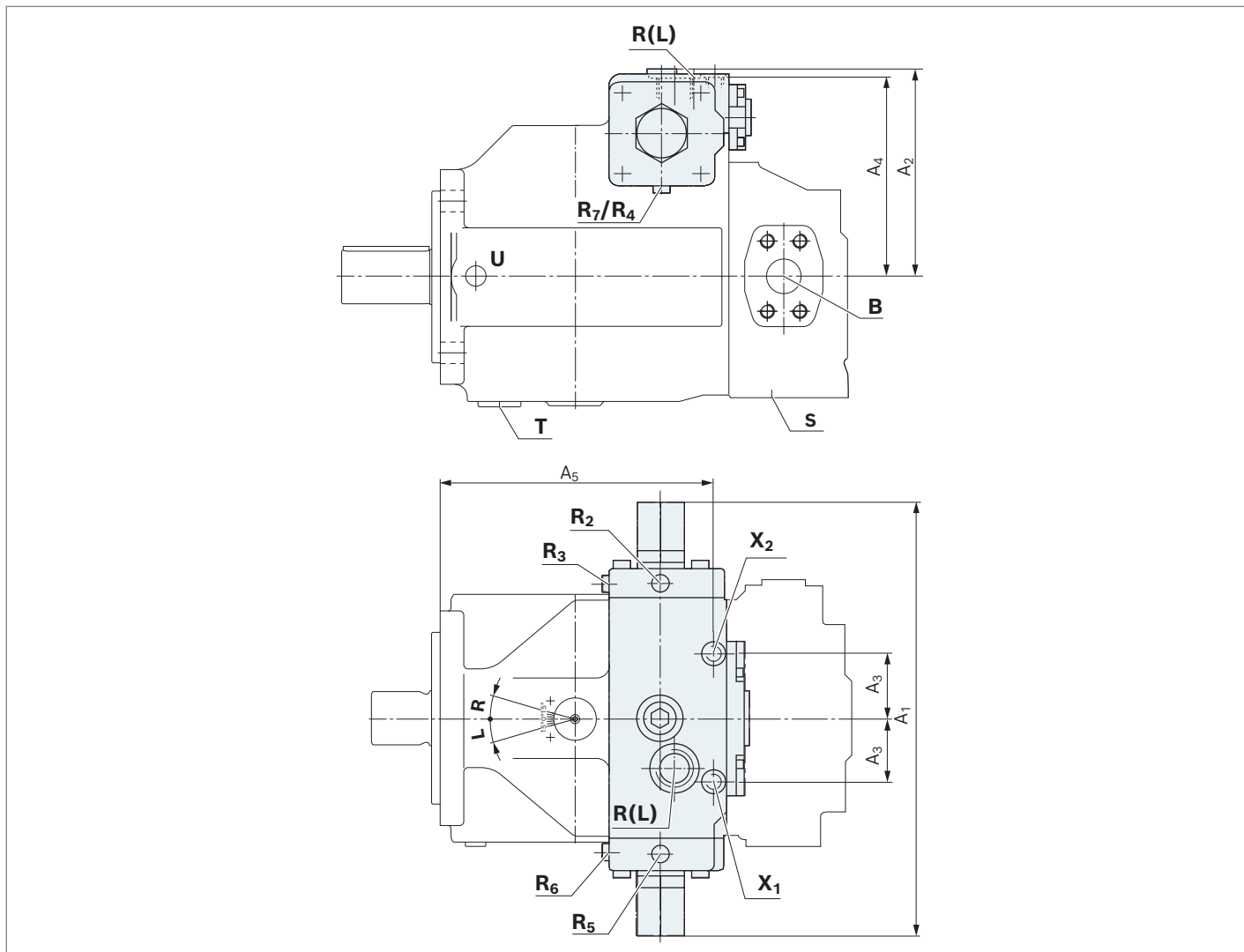

NG	A ₁	A ₂	A ₃	A ₄	A ₅	
125/180 ²⁾	402	191	67	186.5	251	For detailed dimensions and technical data for the variable pump, see data sheet 92050 (A4VSO), 92100 (A4VSG) or 92105 (A4CSG)
250/355 ²⁾	485	238	71	233	311	

Ports	Standard	Size	p_{max} [bar] ¹⁾	State ³⁾	
X ₁ , X ₂	Control pressure	DIN 3852-1	M14 x 1.5; 12 deep (NG 125 and 180)	100 (with HM1)	O
			M18 x 1.5; 12 deep (NG 250 and 355)	350 (with HM2)	O
R ₂ ... R ₇	Air bleeding the stroking chamber	DIN 3852-1	M10 x 1; 8 deep	350 (only with HM2)	X

1) Depending on the application, momentary pressure peaks can occur. Keep this in mind when selecting measuring devices and fittings.

2) Size 180 and 355 only with HM2

3) O = Must be connected (plugged on delivery)
 X = Plugged (in normal operation)

Dimensions HM2

▼ **A4VSO, A4VSG and A4CSG, sizes 500 to 1000**

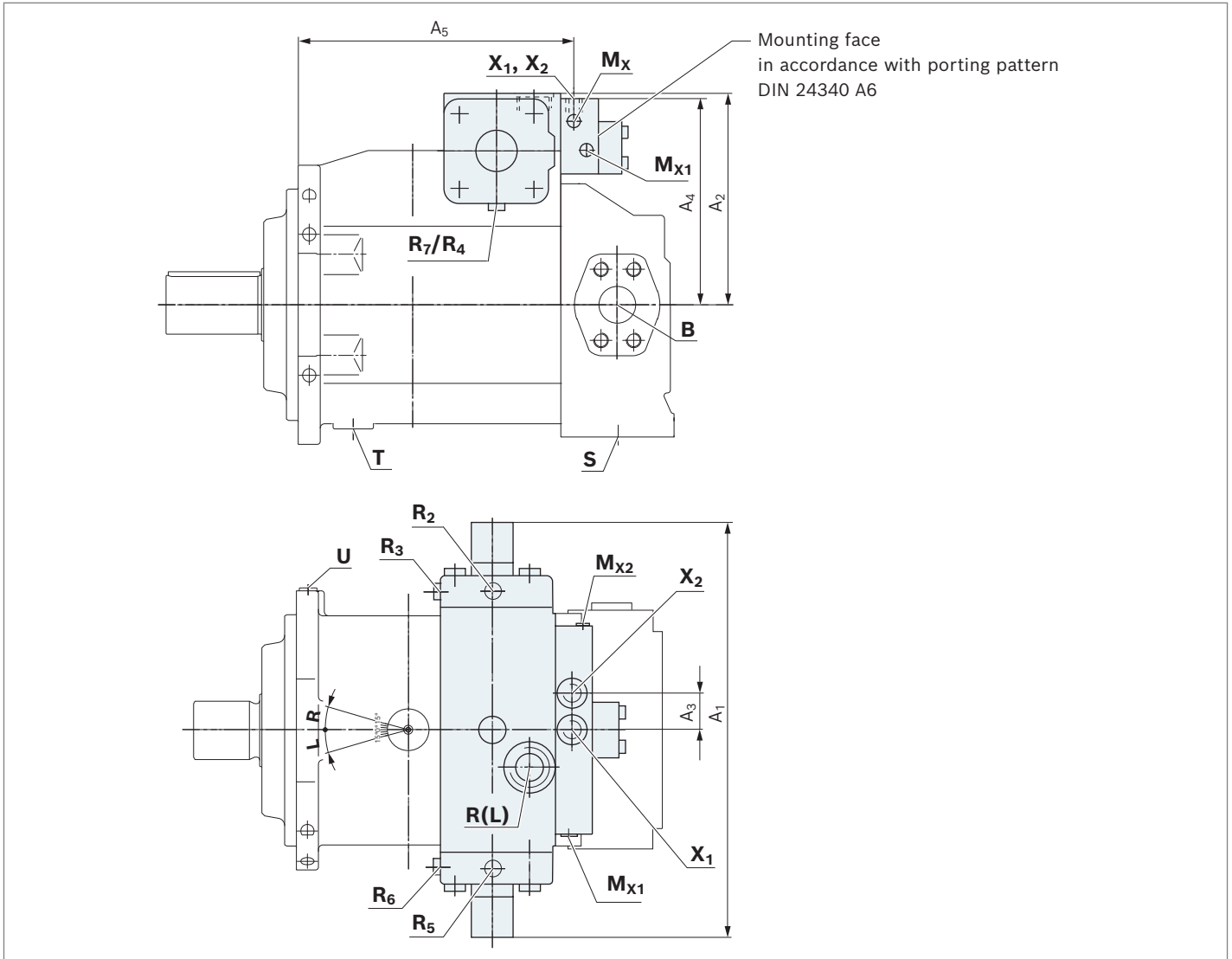

NG	A ₁	A ₂	A ₃	A ₄	A ₅
500	555	283	50	274	388
750	630	320	50	304	420
1000	670	347	50	327	486

For detailed dimensions and technical data for the variable pump, see data sheet 92050 (A4VSO), 92100 (A4VSG) or 92105 (A4CSG)

Ports	Standard	Size ¹⁾	p _{max} [bar] ²⁾	State
X ₁ , X ₂	DIN 3852-1	M27 × 2; 16 deep	350	O
M _X , M _{X1} , M _{X2}	DIN 3852-1	M14 × 1.5; 12 deep	350	X
R ₂ ... R ₇	DIN 3852-1	M14 × 1.5; 12 deep	350	X

1) Depending on the application, momentary pressure peaks can occur. Keep this in mind when selecting measuring devices and fittings.

2) O = Must be connected (plugged on delivery)
 X = Plugged (in normal operation)

HM2C – Customer solution with proportional valve, position transducer

Type	NG	40	71	125	180	250	355	450	500	750	1000	
A4VSO		○	○	●	○	●	○	–	●	○	○	HM2C
A4VBO		–	○	○	–	○	–	○	–	–	–	
A4VSG		○	○	●	○	●	○	–	●	○	○	
A4CSG		–	–	–	–	●	○	–	●	○	–	

The HM2C customer solution provides the base unit, sensors and actuators required for a control system. This means that a pump control system can be built up by the end users themselves for electronic volume, pressure and power control. Notice: No finished pump control electronics is available for the HM2C like for the HS5. The HM2C can be integrated freely in the control architecture of the plant operator machine with defined standard interfaces.

On the pump side, the base unit is equipped with:

- ▶ A proportional valve (including integrated valve amplifier)
- ▶ Swivel angle sensor

All components are already installed and piped up and only have to be connected with the on-site control. The HM2C control receives the setpoint value for the mounted proportional valve from the superordinate control in the form of an electric current signal.

Component	Designation	Material number
Valve	Sizes 40 to 180 4WREE6V08-2X/G24K31/F1V-989 Data sheet 29061	R901438013
	Sizes 250 to 1000 4WREE6V16-2X/G24K31/F1V-989 Data sheet 29061	R901377315
Swivel angle sensor	Standardized output signal 4 to 20 mA and 2 to 10 V	Depending on the size

The pump setting is recorded via the swivel angle sensor. These two parameters are therefore available to the superordinate control.

Example applications:

- ▶ The plant operator wants to retain his own machine control and integrate the pump control in it. This type of customer-specific solution can be set up with the HM2C and the Motion Logic Control (MLC) from Bosch Rexroth, for example. Together with a matching I/O axis module, a freely programmable control is available to the user.

The axis module and the MLC for actuating the HM2C control are not included in the HM2C scope of delivery.

Spring-centering

The spring-centering of the stroking cylinder is standard. It is used for setting and adjustment in the depressurized neutral position, but without a defined reset during high-pressure operation.

Notes

- ▶ The spring feedback in the controller and pump control spring centering are no safety devices. The controller can stick in an undefined position due to internal contamination (contaminated hydraulic fluid, abrasion or residual contamination from system components). As a result, the flow in the axial piston unit will no longer respond correctly to the operator's specifications. Check whether the application on your machine requires additional safety measures to bring the driven consumer to a safe position (immediate stop).

To minimize the control fluid consumption, the stroking chambers are sealed in sizes 125 to 1000 and can be bled via the ports R2 to R7.

Swivel angle limitation

Minimum and maximum swivel angle limitation is mechanically adjustable up to 50 % $V_{g \max}$. For size 500, $V_{g \min}$ is adjustable up to 50 % $V_{g \max}$ and $V_{g \max}$ up to 70 % $V_{g \max}$ (75 % with A4VBO 450).

Notes

Setting with A4VSO (open circuit):

- ▶ The $V_{g \max}$ stop is set to nominal $V_{g \max}$ as standard. Please specify different values in your order
- ▶ The $V_{g \min}$ stop is set to nominal $V_g = 0$ l/min with $P_{HD} = 20$ bar as standard. Other values should be specified when placing the order.

When ordering, please state other setting requests in plain text.

Technical data HM2C

Size		NG	125	250	500
Control pressure (in P)	p_{min}	bar	100	125	150
	p_{max}	bar	350	350	350
Control stroke	s_{max}	mm	20.7	25.9	32.6
Control area	A	cm ²	18.1	28.3	38.2
Control volume	$V_{S max}$	cm ³	37.5	73.2	124.5
Weight: approx. (A4VSO...HM2...N00)	m	kg	92	194	327

To ensure the functional reliability for the HM2C proportional valve, the operating fluid must have a min. cleanliness level of 20/18/15 as defined in ISO 4406.

Circuit diagrams HM2C

▼ **Sizes 125 to 250**

Example: open circuit A4VSO HM2C

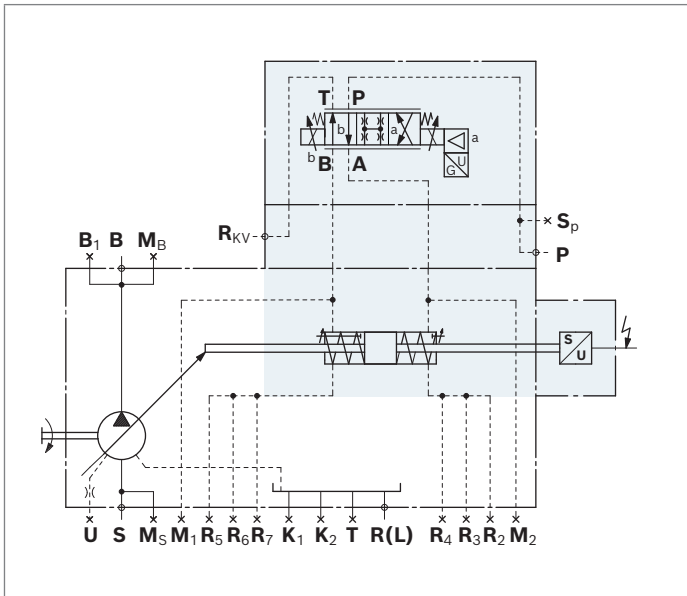

▼ **Size 500**

Example: open circuit A4VSO HM2C

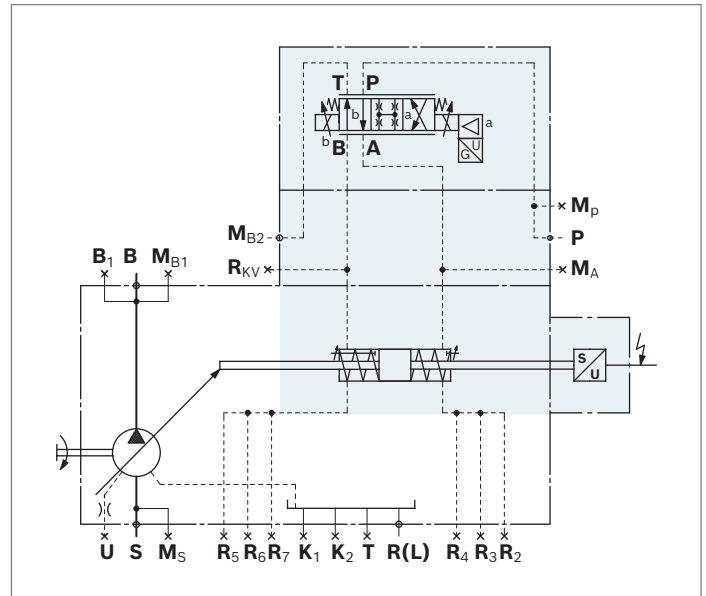

Dimensions HM2C

▼ **A4VSO, A4VSG and A4CSG, size 125, 250**

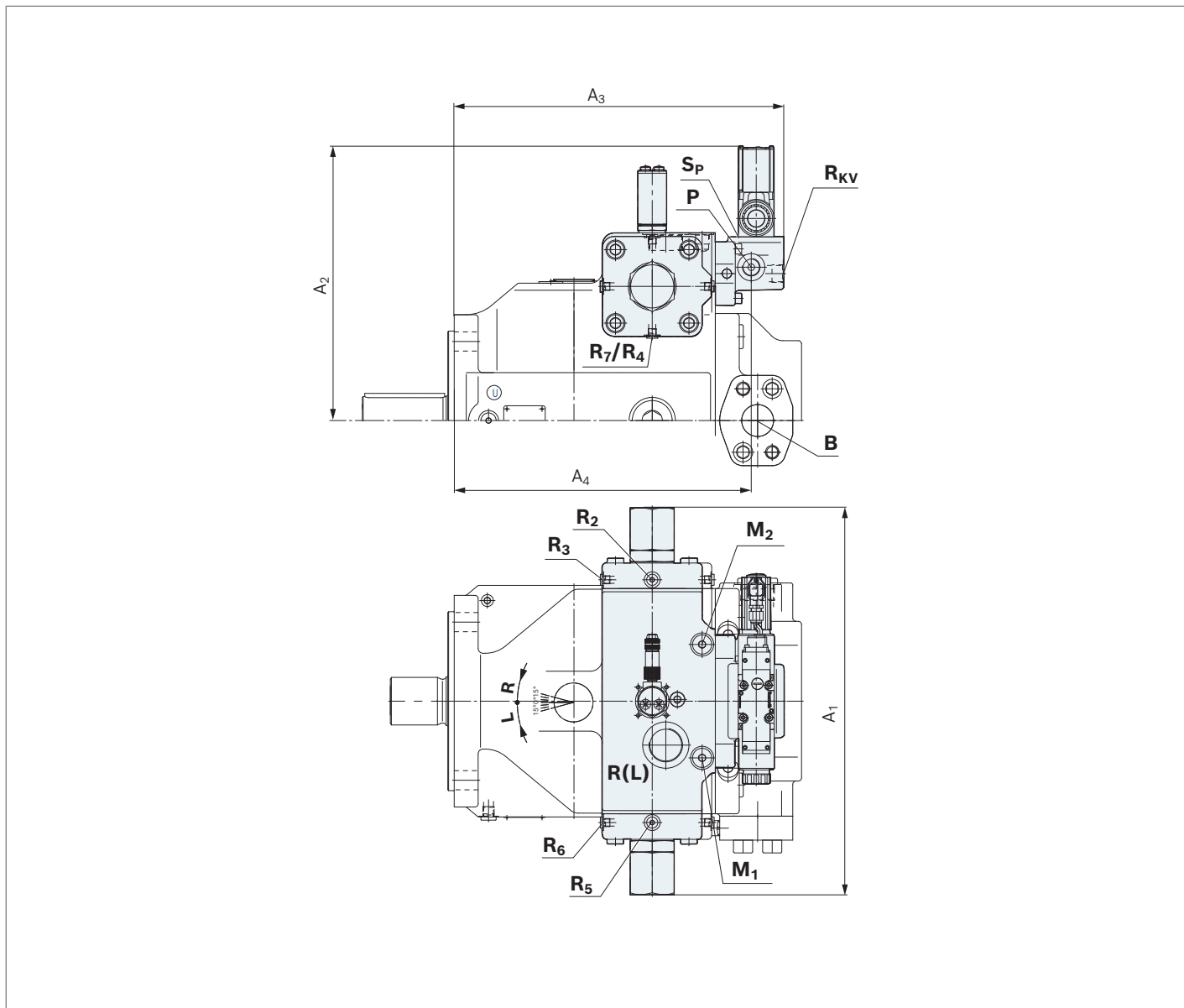

NG	A ₁	A ₂	A ₃	A ₄	
125	401	304	350	309	For detailed dimensions and technical data for the variable pump, see data sheet 92050 (A4VSO), 92100 (A4VSG) or 92105 (A4CSG)
250	485	344	412	372	

Ports	Standard	Size	p _{max} [bar] ¹⁾	State ²⁾
P, R _{KV}	DIN 3852-1	M27 × 2	100	O
M ₁ , M ₂	DIN 3852-1	M14 × 1.5	315	X
R ₂ ... R ₇	DIN 3852-1	M14 × 1.5	315	X

The **R_{KV}** port must be unloaded to the reservoir.

1) Depending on the application, momentary pressure peaks can occur. Keep this in mind when selecting measuring devices and fittings.

2) O = Must be connected (plugged on delivery)
 X = Plugged (in normal operation)

Dimensions HM2C

▼ **A4VSO, A4VSG and A4CSG, size 500**



NG	A ₁	A ₂	A ₃	A ₄	A ₅	A ₆	A ₇	
500	555	363	520	274	388	50	392	For detailed dimensions and technical data for the variable pump, see data sheet 92050 (A4VSO), 92100 (A4VSG) or 92105 (A4CSG)

Ports	Standard	Size	p _{max} [bar] ¹⁾	State ²⁾	
P, R _{KV}	Control pressure	DIN 3852-1	M27 × 2	100	O
M ₁ , M ₂	Control pressure measuring	DIN 3852-1	M14 × 1.5	315	X
R ₂ ... R ₇	Air bleeding the stroking chamber	DIN 3852-1	M14 × 1.5	315	X

The **R_{KV}** port must be unloaded to the reservoir.

1) Depending on the application, momentary pressure peaks can occur. Keep this in mind when selecting measuring devices and fittings.

2) O = Must be connected (plugged on delivery)
 X = Plugged (in normal operation)

HS5(P) – electro-hydraulic control with control valve

Type	NG	40	71	125	180	250	355	450	500	750	1000	
A4VSO, A4VSG		●	●	●	●	●	●	–	●	●	●	HS5(P)
A4CSG		–	–	–	–	●	●	–	●	●	–	
A4VBO		–	●	●	–	●	–	●	–	–	–	

For electric displacement and pressure control as well as torque limitation with VT-HPC-1-1X with external control pressure supply

The control **HS5** sets the displacement of the pump with the mounted direct operated control valve proportional to the setpoint value.

The pump setting is reported by an inductive position transducer.

With **HS5P**, the mounted pressure transducer HM20 (see data sheet 30272) records the system pressure, with A4VSG and A4CSG, each pressure side is assigned a pressure transducer.

Together with the relevant control electronics VT-HPC-1-1X and the operating software IndraWorks, the user has a precise and freely parameterizable control, which offers a comfortable operating and diagnosis interface.

The digital control amplifier VT-HPC-1-1X for actuating the HS5 control is not included in the scope of delivery, please order separately in accordance with data sheet 30237.

The programming of the digital control electronics takes place via the Ethernet interface of the IndraWorks operating software.

Machine and system dynamics must be optimized by the system operator using the pressure control function.

Spring-centering

The spring-centering of the stroking cylinder is standard. It is used for setting and adjustment in the depressurized neutral position, but without a defined reset during high-pressure operation.

Notes

- ▶ The spring feedback in the controller and pump control spring centering are no safety devices. The controller can stick in an undefined position due to internal contamination (contaminated hydraulic fluid, abrasion or residual contamination from system components). As a result, the flow in the axial piston unit will no longer respond correctly to the operator's specifications. Check whether the application on your machine requires additional safety measures to bring the driven consumer to a safe position (immediate stop).

To minimize the control fluid consumption, the stroking chambers are sealed in sizes 125...1000 and can be bled via the ports **R₂** ... **R₇**.

Swivel angle limitation

Minimum and maximum swivel angle limitation is mechanically adjustable up to 50 % $V_{g \max}$. For size 500, $V_{g \min}$ is adjustable up to 50 % $V_{g \max}$ and $V_{g \max}$ up to 70 % $V_{g \max}$ (75 % with A4VBO 450).

Notes

Setting with A4VSO (open circuit):

- ▶ The $V_{g \max}$ stop is set to nominal $V_{g \max}$ as standard. Please specify different values in your order
- ▶ The $V_{g \min}$ stop is set to nominal $V_g = 0$ l/min with $P_{HD} = 20$ bar as standard. Other values should be specified when placing the order.

Setting with A4VSG and A4CSG (closed circuit):

- ▶ The $V_{g \max}$ stops are set on both sides to nominal $V_{g \max}$.

When ordering, please state other setting requests in plain text.

To ensure the functional reliability for the HS5(V)(L) control system, the operating fluid must have a min. cleanliness level of 18/16/13 as defined in ISO 4406.

Optional:

- ▶ **HS5P** with one (open circuit) or two (closed circuit) pressure transducer(s) for pressure control and torque limitation
- ▶ Speed variation possible with SD card: VT-SD-HPC-HS5n. For description, see data sheet 30237-Z.

Technical data HS5(P)

Size		NG	40	71	125	180	250	355	450	500	750	1000	
Control pressure (in P)	A4VSO, A4VSG, A4CSG	p_{min}	bar	100	100	100	125	125	125	–	150	150	150
	A4VBO	p_{min}	bar	–	130	130	–	–	–	190	–	–	–
		$p_{max}^{1)}$	bar	350	350	350	350	350	350	350	350	350	350
Control stroke		s_{max}	mm	14.2	17.1	20.7	20.7	25.9	25.9	29.34	32.6	37.0	41.4
Control area		A	cm ²	8.1	12.6	18.1	18.1	28.3	28.3	38.2	38.2	56.8	63.6
Control volume		$V_{S\ max}$	cm ³	11.4	21.5	37.5	37.5	73.2	73.2	112.1	124.5	210	263.3
Actuating time		$t_{min}^{2)}$	s	0.04	0.06	0.09	0.09	0.12	0.12	0.15	0.15	0.2	0.25
Weight: approx. (A4VSO...HS5...N00)	m	kg	42	59	98	112	200	220	–	333	476	606	
Weight (approx.) (A4VBO...HS5...N00)	m	kg	–	65	100	–	195	–	390	–	–	–	
Control loop performance hysteresis													≤ 0.2%
Repeat accuracy													≤ 0.2%
Linearity deviation swivel angle													≤ 1.0%
Linearity deviation pressure													≤ 1.5% of $p_{max}^{3)}$

A4VSO – open circuit

▼ **Characteristic curve**

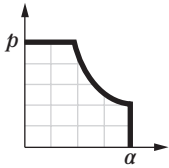

Basic setting for design without short circuit valve, de-energized proportional valve and connected control pressure: $V_{g\ min}$ (see table).

▼ **Flow direction S to B**

Direction of rotation	Swiveling range ⁴⁾	Basic setting
clockwise	counter-clockwise	$V_{g\ min}$ (counter-clockwise)
counter-clockwise	clockwise	$V_{g\ min}$ (clockwise)

- 1) Due to the permissible data of the proportional valve
- 2) With minimum control pressure
- 3) Pressure transducer value

A4VSG and A4CSG – closed circuit

▼ **Characteristic curve**

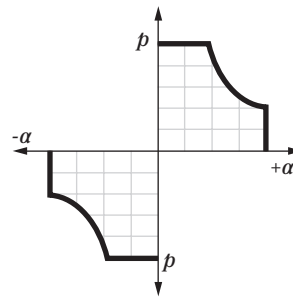

Basic setting for design without short circuit valve, de-energized proportional valve and connected control pressure: $V_{g\ max}$ (see table).

▼ **Flow direction**

Direction of rotation	Swiveling range ⁴⁾	Flow direction	Basic setting
clockwise	clockwise	B to A	$V_{g\ max}$ clockwise
	counter-clockwise	A to B	
counter-clockwise	clockwise	A to B	$V_{g\ max}$ counter-clockwise
	counter-clockwise	B to A	

4) See swivel angle indicator

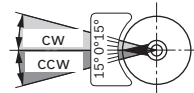

Circuit diagrams HS5(P)

▼ **Sizes 40 and 71**

Example: A4VSO HS5P (with pressure transducer)

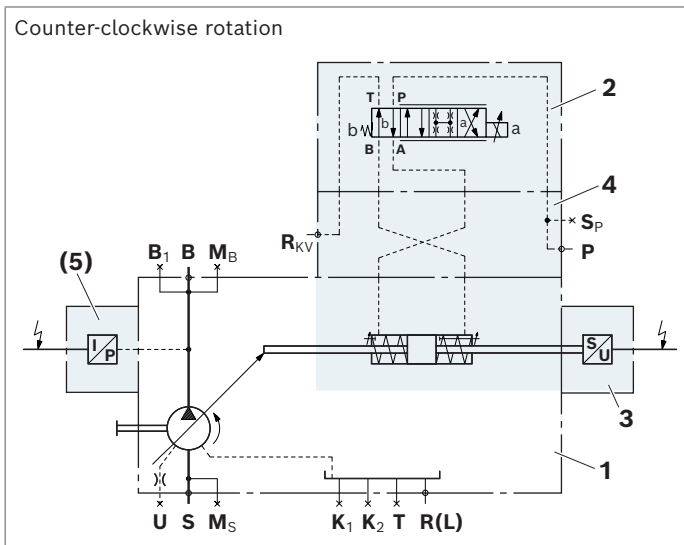
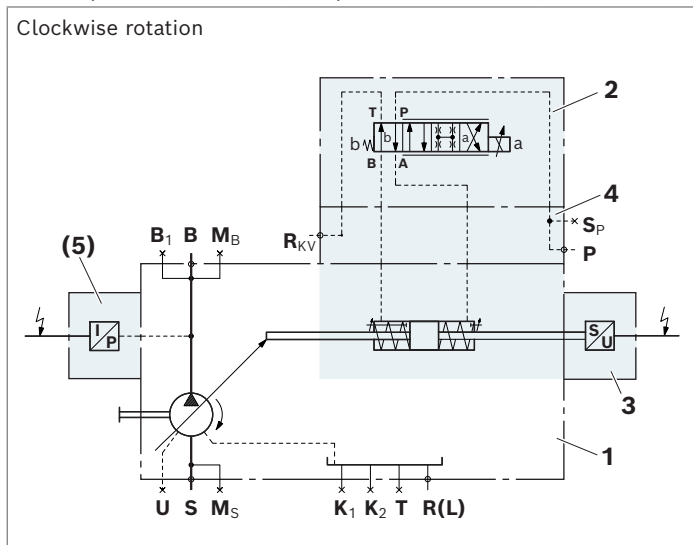

▼ **Sizes 125 to 355**

Example: A4VSO HS5P (with pressure transducer)

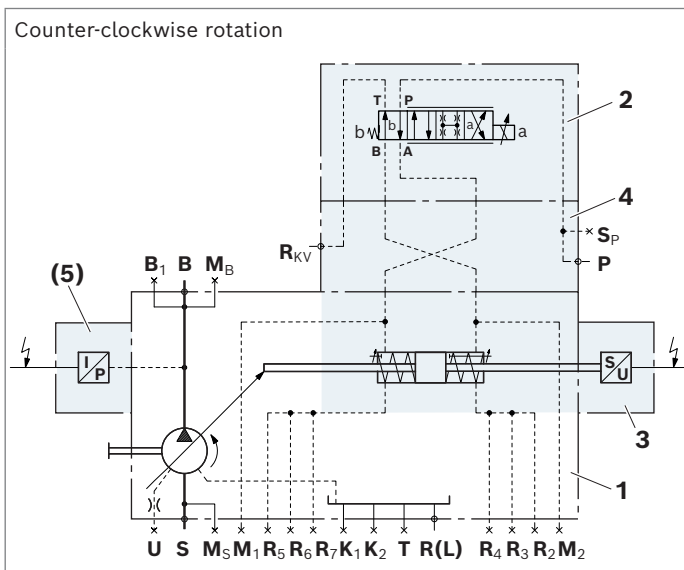
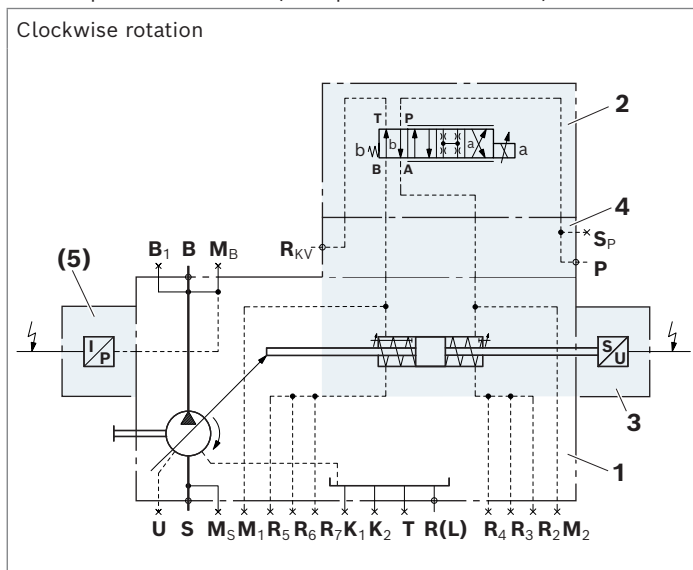

- 1 Pump with hydraulic control device
 A4VSO (see data sheet 92050), A4VBO (see data sheet 92122)
- 2 4/4 directional control valve (see data sheet 29027)

NG	Type
40 to 180	4WRPH6CA24L-2X/G24Z4/V-855
250 and 355	4WRPH6CA40L-2X/G24Z4/V-855

- 3 Inductive position transducer

NG	Type
40, 125 and 180	AWAX004D03
71	AWAX004D02 with spacer
250, 355	AWAX004D02

with round connector 4-pin M12 × 1

- 4 Intermediate plate
 - The **R_{kV}** port must be unloaded to the reservoir.
- 5 **Only with HS5P:** Pressure transducer HM20-2X/630-C-K35 (see data sheet 30272) with intermediate flange, with A4VSG and A4CSG, each pressure side has 1 pressure transducer assigned and mounted

▼ **Sizes 500 to 1000**

Example: A4VSG HS5P (with pressure transducer)

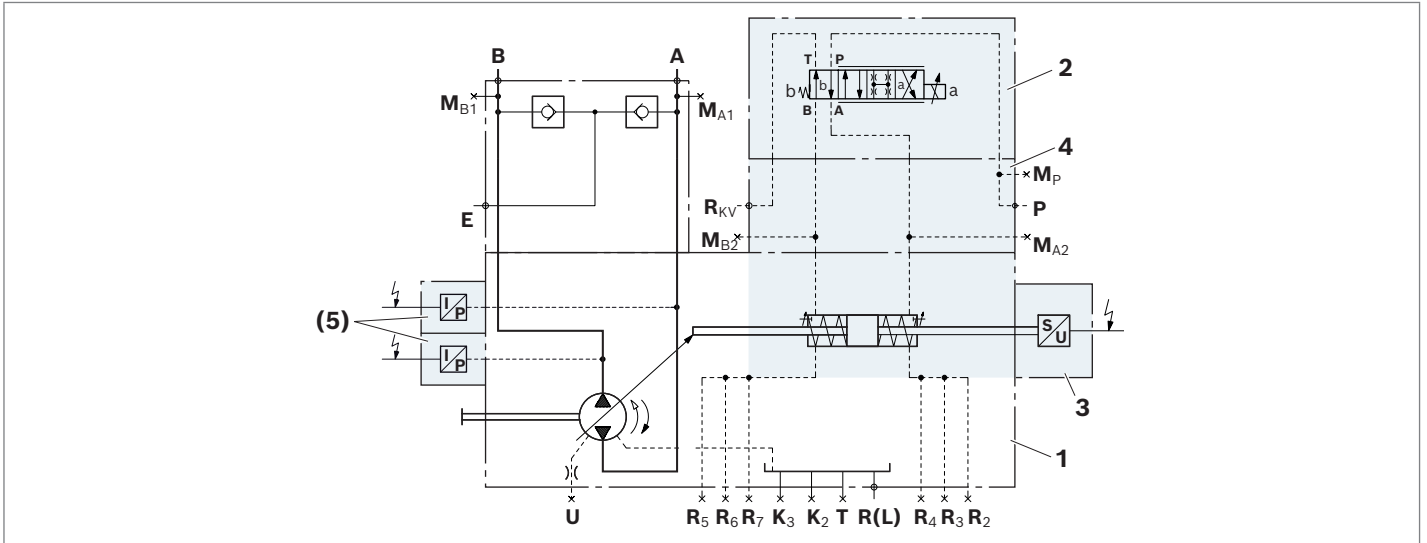

- 1 Pump with hydraulic control device
A4VSG (see data sheet 92100)
- 2 4/4 directional control valve (see data sheet 29027)

NG	Type
500 to 1000	4WRPH6CA40L-2X/G24Z4/V-855

- 3 Inductive position transducer

NG	Type
500 to 1000	AWAX004D02

with round connector 4-pin M12 × 1

- 4 Intermediate plate
- The **R_{kv}** port must be unloaded to the reservoir.
- 5 **Only with HS5P:** Pressure transducer HM20-2X/630-C-K35 (see data sheet 30272) with intermediate flange, with A4VSG and A4CSG, each pressure side has 1 pressure transducer assigned and mounted

Ports	
P	Control pressure
S_p	Control pressure accumulator
R_{kv}	Control fluid return flow
M...	Measuring ports control pressure
R₂ ... R₇	Air bleeding the stroking chamber

Dimensions HS5(P)

▼ **Size 40 and 71; example: A4VSO HS5P with pressure transducer in B** (clockwise rotation with; counter-clockwise without HM20)

With A4VSO and A4VBO counter-clockwise and clockwise rotation, partly different components and dimensions.
 With A4VSG, the dimensions "L" apply for both directions of rotation.

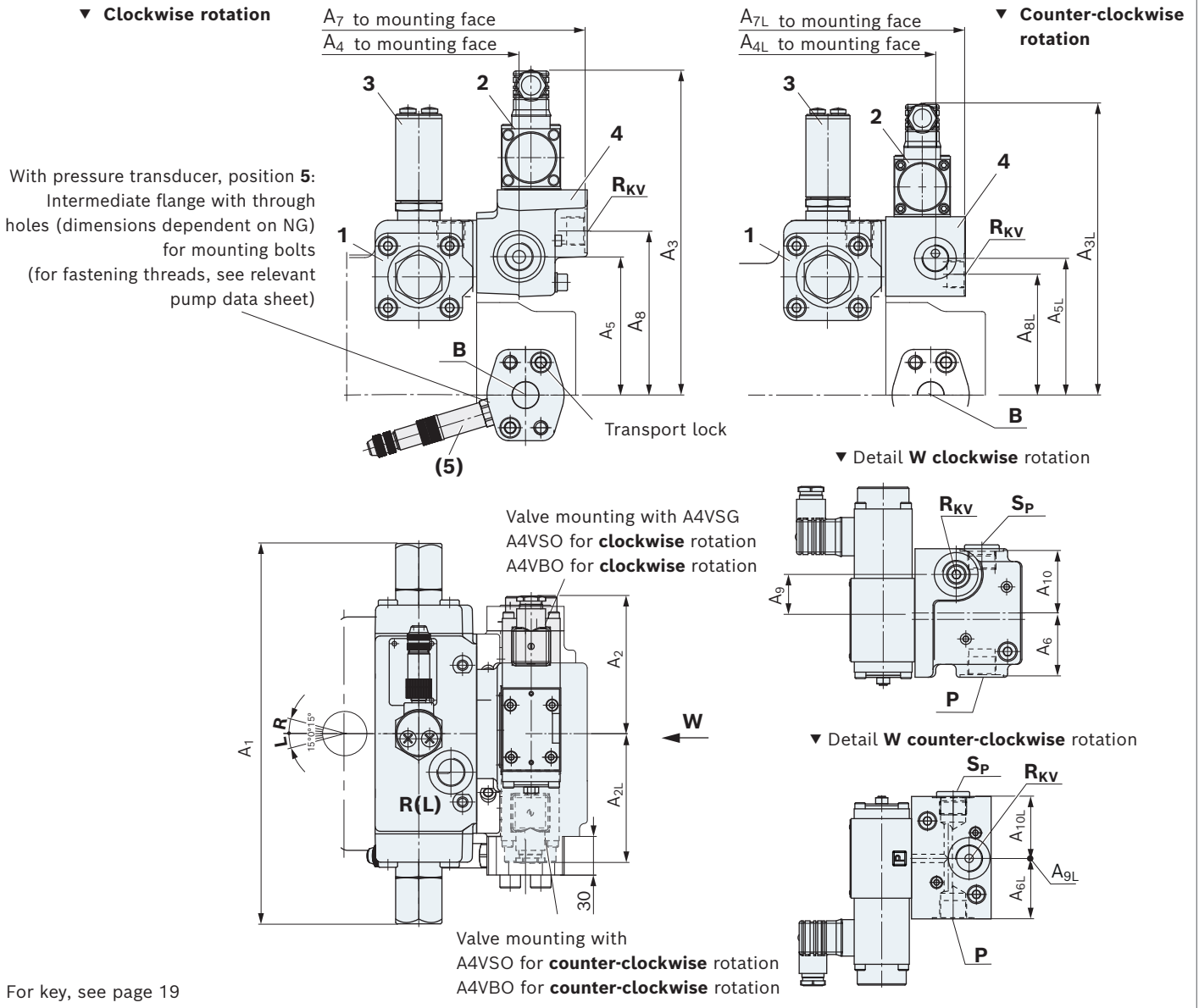

NG	A ₁	A ₂	A _{2L}	A ₃	A _{3L}	A ₄	A _{4L}	A ₅	A _{5L}	A _{6(L)}	A ₇	A _{7L}	A ₈	A _{8L}	A ₉	A _{9L}	A _{10(L)}
40	296	110.3	104	251	232	222	229.5	108	107	48	273	253	128	94	30	0	48
71	332	105.3	107.1	268	249	249	256.5	123	122	48.4	300	280	143	109	30	0	49.6

For detailed dimensions and technical data for the variable pump, see data sheets 92050 (A4VSO), 92122(A4VBO) or 92100 (A4VSG)

Ports	Standard ¹⁾	Size	p _{max} [bar] ²⁾	State ³⁾
P	Control pressure	DIN 3852-1 M22 × 1.5; 14 deep	350	O
S _P	Control pressure accumulator	DIN 3852-1 M22 × 1.5; 14 deep	350	X
R _{KV}	Control fluid return flow	DIN 3852-1 M22 × 1.5; 14 deep	4	O

1) ISO 6149 with A4VBO 71

2) Depending on the application, momentary pressure peaks can occur. Keep this in mind when selecting measuring devices and fittings.

3) O = Must be connected (plugged on delivery)
 X = Plugged (in normal operation)

▼ **Size 125 to 355, example A4VSO HS5P with a pressure transducer on port B**

With A4VSO and A4VBO, the dimension A_4 is different for clockwise and counter-clockwise rotation.
 With A4VSG and A4CSG, dimension A_{4R} (clockwise) applies for both directions of rotation.

With pressure transducer, position 5:
 Intermediate flange with through holes
 (dimensions dependent on NG)
 for mounting bolts
 (for fastening threads, see respective
 pump data sheet)

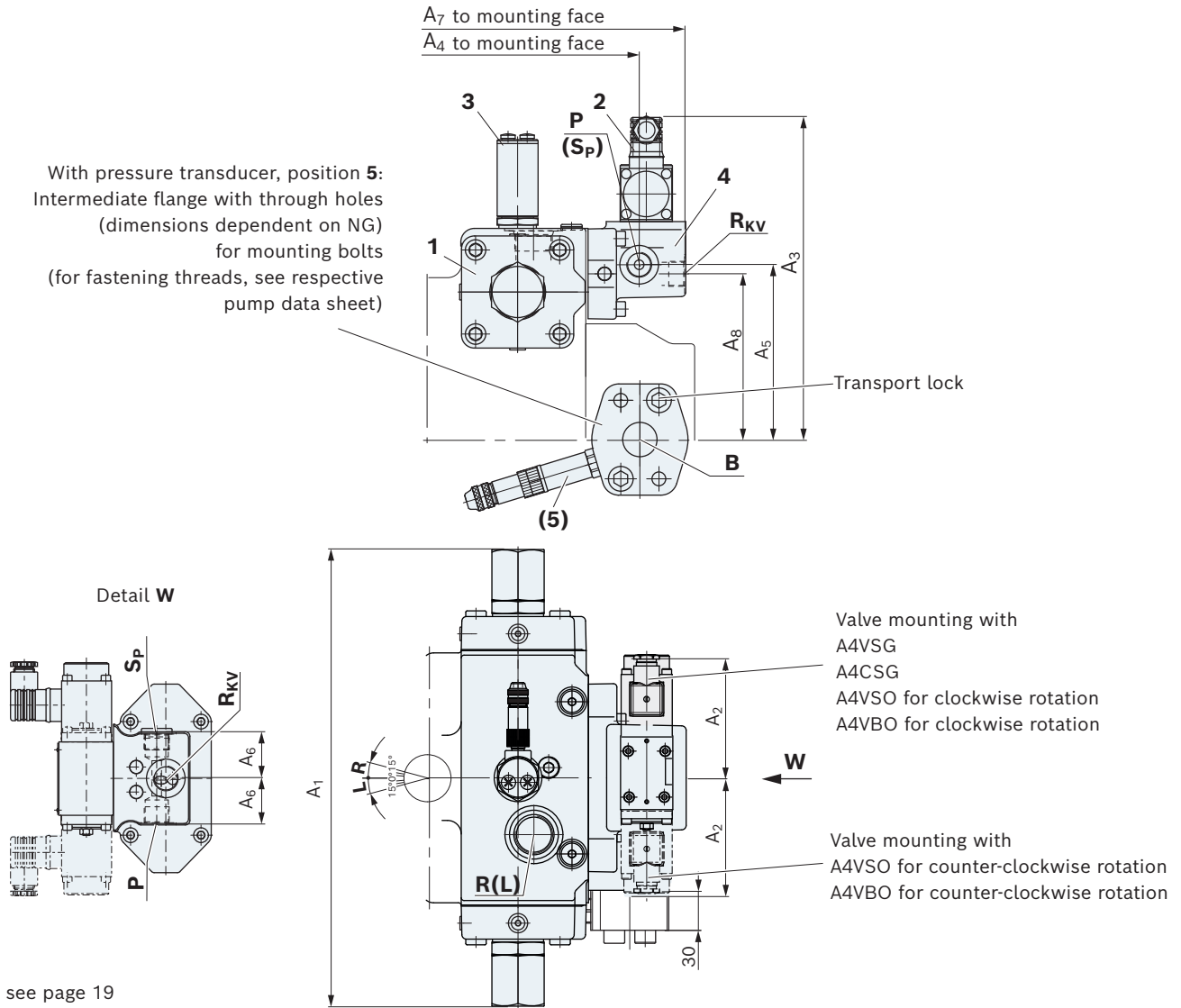

For key, see page 19

NG	A_1	A_3	A_{4R}	A_{4L}	A_5	A_6	A_7	A_8	
125/180	402	286	310	318.5	156	39	350	148	For detailed dimensions and technical data for the variable pump, see data sheet 92050 (A4VSO), 92122(A4VBO), 92100 (A4VSG) or 92105 (A4CSG)
250/355	485	322	372	380.5	192	39	412	184	

Ports	Standard ¹⁾	Size	p_{max} [bar] ²⁾	State ³⁾	
P	Control pressure	DIN 3852-1	M22 × 1.5; 14 deep	350	O
S_p	Control pressure accumulator	DIN 3852-1	M22 × 1.5; 14 deep	350	X
R_{KV}	Control fluid return flow	DIN 3852-1	M22 × 1.5; 14 deep	4	O
M_1, M_2	Control pressure measuring	DIN 3852-1	M14 × 1.5; 12 deep (NG 125 and 180) M18 × 1.5; 12 deep (NG 250 and 355)	350 350	X X
$R_2 \dots R_7$	Air bleeding the stroking chamber	DIN 3852-1	M10 × 1; 8 deep	350	X

1) ISO 6149 with A4VBO 71

2) Depending on the application, momentary pressure peaks can occur. Keep this in mind when selecting measuring devices and fittings.

3) O = Must be connected (plugged on delivery)
 X = Plugged (in normal operation)

▼ **A4VSO, A4VBO, A4VSG and A4CSG, size 500 to 1000**

Example A4VSG HS5P with two pressure transducers on port **B**

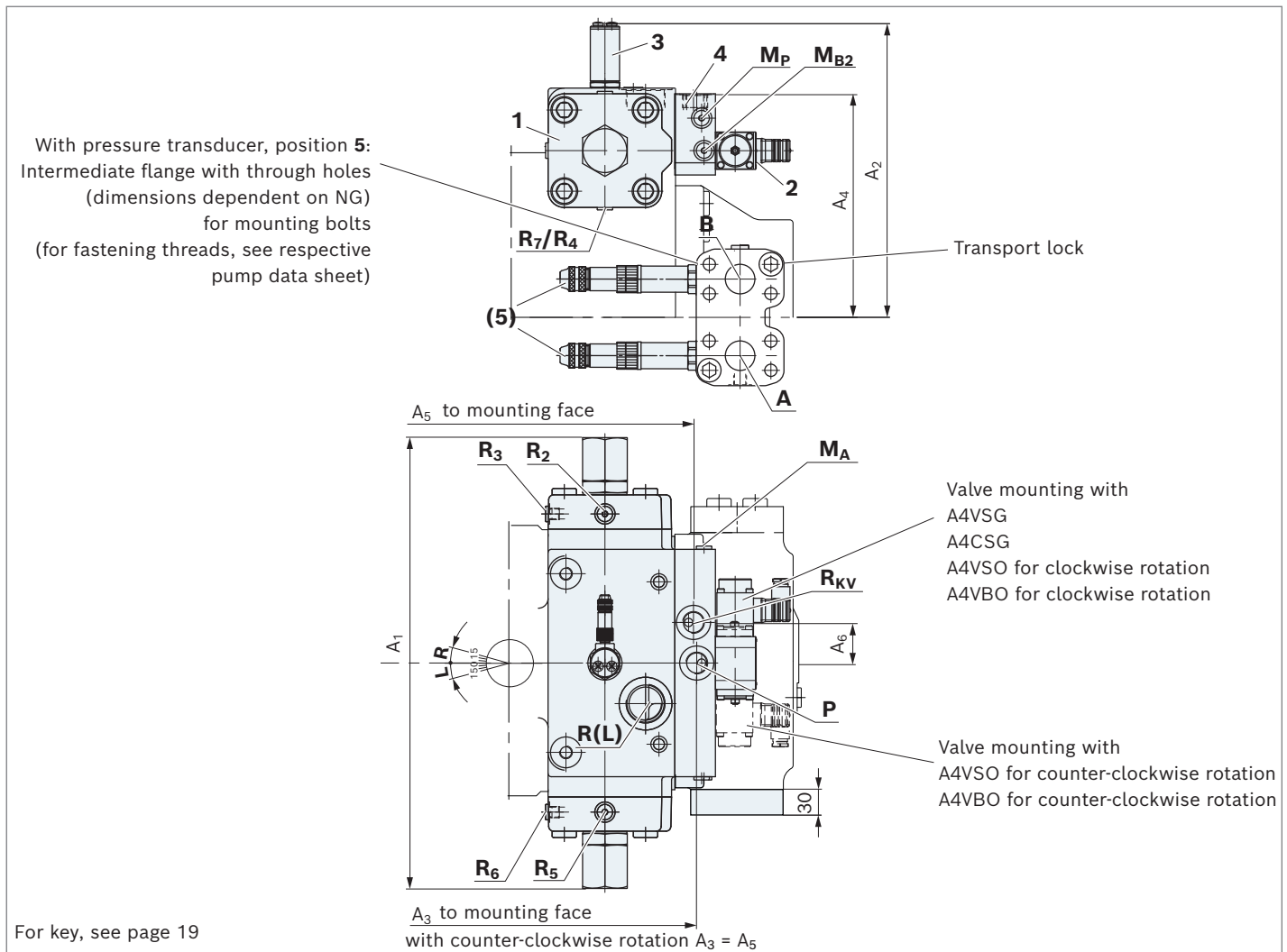

NG	A ₁	A ₂	A ₃	A ₄	A ₅	A ₆	
500 (450 with A4VBO)	555	363	392	274	388	50	For detailed dimensions and technical data for the variable pump, see data sheet 92050 (A4VSO), 92122 (A4VBO), 92100 (A4VSG) or 92105 (a4CSG)
750	630	402	424	304	420	50	
1000	670	429	490	327	486	50	

Ports	Standard ¹⁾	Size	p _{max} [bar] ²⁾	State ³⁾
P	Control pressure	DIN 3852-1 M27 × 2; 16 deep	350	O
R_{KV}	Control fluid return flow	DIN 3852-1 M27 × 2; 16 deep	4	O
M_{A2}, M_{B2}, M_P	Control pressure measuring	DIN 3852-1 M14 × 1.5; 12 deep	350	X
R₂ ... R₇	Air bleeding the stroking chamber	DIN 3852-1 M14 × 1.5; 12 deep	350	X

The **R_{KV}** port must be unloaded to the reservoir.

1) ISO 6149 with A4VBO 71

2) Depending on the application, momentary pressure peaks can occur. Keep this in mind when selecting measuring devices and fittings.

3) O = Must be connected (plugged on delivery)

X = Plugged (in normal operation)

HS5M – suitable for use under fluid

Type	NG	40	71	125	180	250	355	450	500	750	1000	
A4VSO, A4VSG		●	●	●	●	●	●	–	●	●	●	HS5M
A4VBO		–	●	●	–	●	–	●	–	–	–	

The variant **HS5M** corresponds to the HS5 design, but without proportional valve, but with pilot pressure ports **X₁** and **X₂**.

The proportional valve can be positioned separately in the system and piped up via the designated ports **X₁** and **X₂** of the pump.

The unit can be installed in the reservoir together with the directly mounted position transducer.

Approved for HLP fluids DIN 51524.

Recommendation

- ▶ Directional control valve 4WRPH6, see data sheet 29027
- ▶ Electronics VT-HPC-1-1X see data sheet 30237
- ▶ For cables, see data sheet 30237-B

Notes

Setting with A4VSO (open circuit):

- ▶ The $V_{g \max}$ stop is set to nominal $V_{g \max}$ as standard. Please specify different values in your order
- ▶ The $V_{g \min}$ stop is set to nominal $V_g = 0$ l/min with $P_{HD} = 20$ bar as standard. Other values should be specified when placing the order.

Setting with A4VSG and A4CSG (closed circuit):

- ▶ The $V_{g \max}$ stops are set on both sides to nominal $V_{g \max}$.

▼ Flow direction in closed circuit

Direction of rotation		Swiveling range ¹⁾
clockwise	counter-clockwise	
B to A	A to B	clockwise
A to B	B to A	counter-clockwise

▼ Flow direction in open circuit

Direction of rotation		Swiveling range ¹⁾
clockwise	counter-clockwise	
S to B		counter-clockwise
	S to B	clockwise

Technical data inductive position transducer AWAX

Temperature range	-25 °C to +80 °C for AWAX004D02 and AWAX004D03
Type of protection	IPX7 DIN VDE 0470-EN 60529
Typical temperature drift	0.05% / K (based on the total output voltage swing)
Vibration resistance	10 g sine; 10 g noise; 15 g shock
Use under fluid	approved for HLPD 46 (with installed mating connector)
Sealing material	FKM

Technical data HS5M

Size		NG	40	71	125	180	250	355	450	500	750	1000	
Control pressure (in X₁ / X₂)	A4VSO, A4VSG	p_{\min}	bar	50	50	50	100	100	100	–	125	125	125
	A4VBO	p_{\min}	bar	–	100	100	–	–	–	160	–	–	–
		$p_{\max}^{1)}$	bar	350	350	350	350	350	350	350	350	350	350
Control stroke		s_{\max}	mm	14.2	17.1	20.7	20.7	25.9	25.9	29.34	32.6	37.0	41.4
Control area		A	cm ²	8.1	12.6	18.1	18.1	28.3	28.3	38.2	38.2	56.8	63.6
Control volume		$V_{S \max}$	cm ³	11.4	21.5	37.5	37.5	73.2	73.2	112.1	124.5	210	263.3
Weight (approx.) (A4VS...HS5M...N00)		m	kg	38	55	92	106	184	214	–	327	470	600
Weight (approx.) (A4VBO...HS5M...N00)		m	kg	–	65	100	–	195	–	390	–	–	–

1) See swivel angle indicator

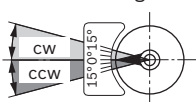

Circuit diagrams HS5M

- ▼ **Size 40 to 1000 for A4VSO and A4VSG, size 250 to 750 for A4CSG**
 Example: A4VSO...HS5M, size 125 to 1000

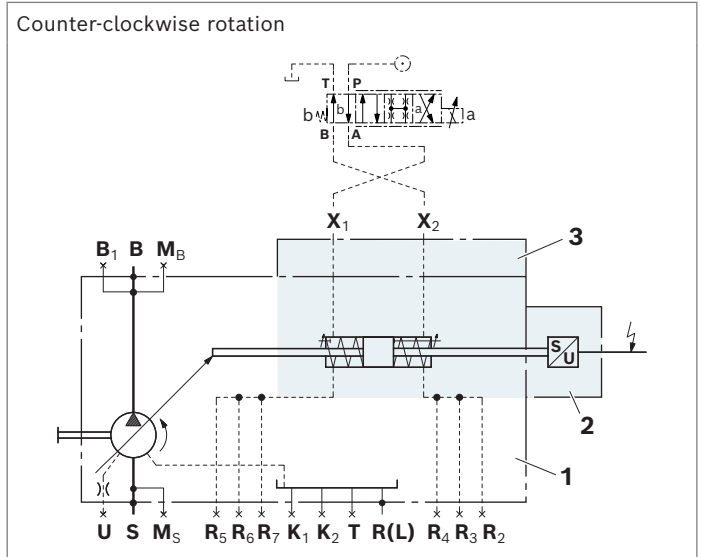
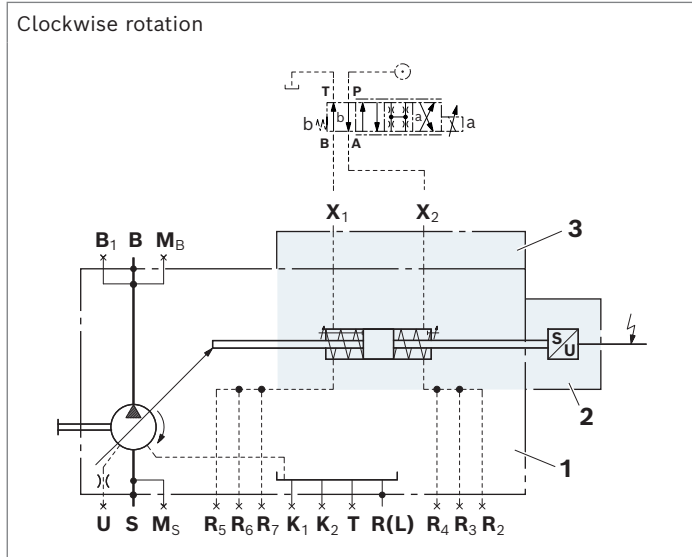

- 1 Pump with hydraulic control device
 A4VSO (see data sheet 92050)
- 2 Inductive position transducer:

NG	Type
40, 125 and 180	AWAX004D03
71	AWAX004D02 with spacer
250 to 1000	AWAX004D02

with round connector 4-pin M12 × 1

- 3 Port plate

Ports	
X ₁	Control pressure
X ₂	Control pressure
R ₂ ... R ₇	Air bleeding of stroking chamber (NG 125 to 1000)

Dimensions HS5M

▼ **A4VSO, A4VSG and A4CSG, size 40, 71, 500 and 750**

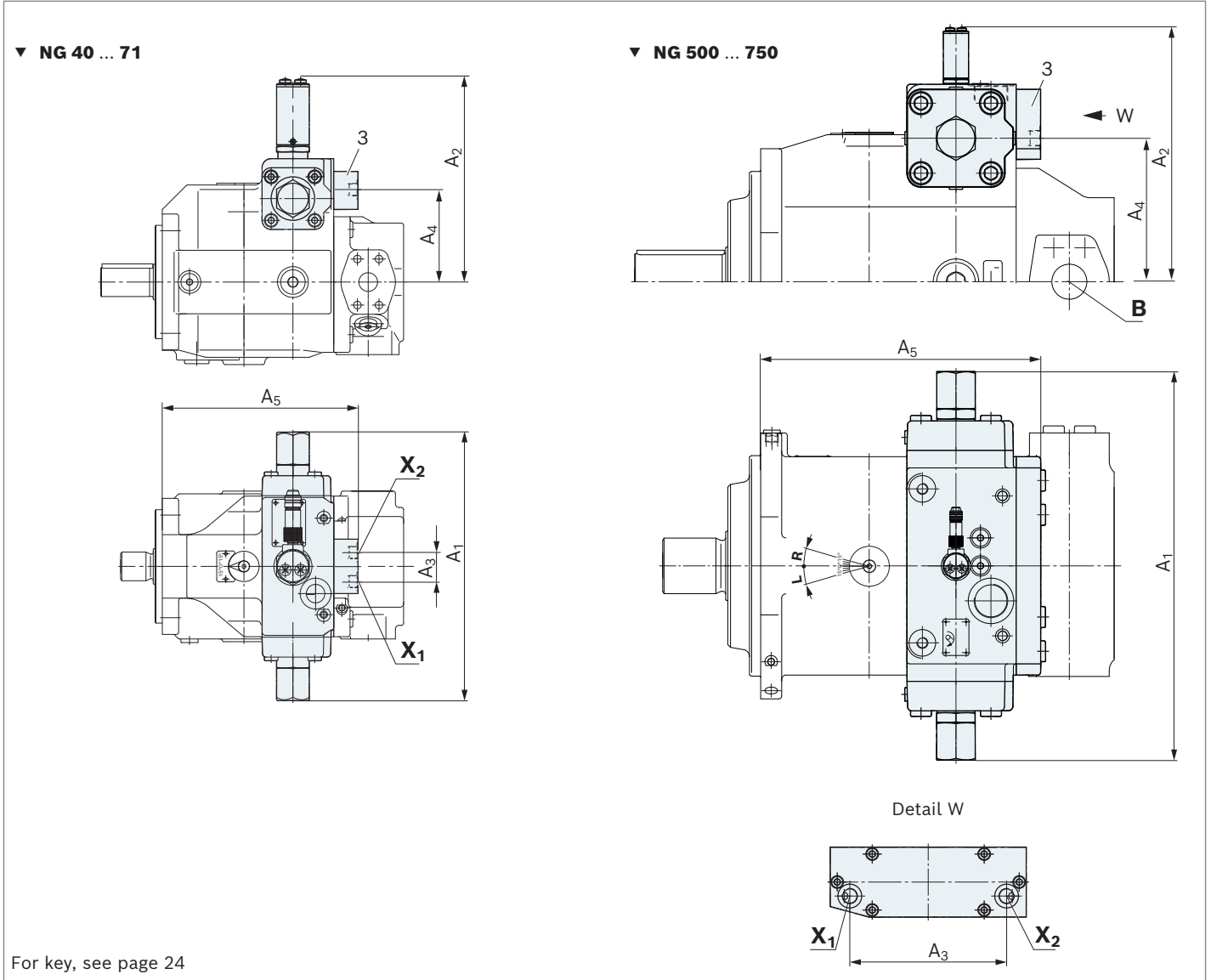

NG	A ₁	A ₂	A ₃	A ₄	A ₅
40	296	223.7	28	104	218
71	332	243	28	120	245
500	555	363	224	205	399
750	630	400	224	235	431

For detailed dimensions and technical data for the variable pump, see data sheet 92050 (A4VSO), 92100 (A4VSG) or 92105 (A4CSG)

Ports	Standard	Size	p_{max} [bar] ¹⁾	State ²⁾
X ₁ , X ₂	DIN 3852-1	M14 × 1.5; 12 deep (NG 40 and 71) M22 × 1.5; 14 deep (NG 500)	350	O
			350	O

1) Depending on the application, momentary pressure peaks can occur. Keep this in mind when selecting measuring devices and fittings.

2) O = Must be connected (plugged on delivery)
 X = Plugged (in normal operation)

▼ **A4VSO, A4VSG and A4CSG, sizes 125 to 355**

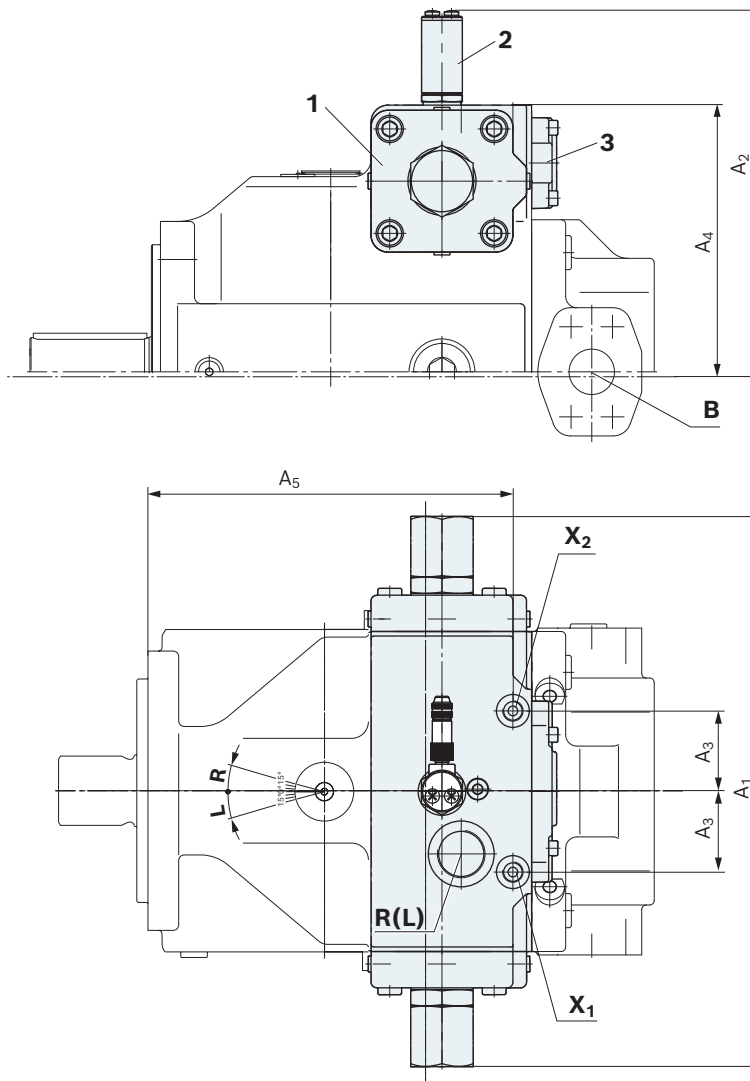

For key, see page 24

NG	A ₁	A ₂	A ₃	A ₄	A ₅	
125/180	402	272	67	186.5	251	For detailed dimensions and technical data for the variable pump, see data sheet 92050 (A4VSO), 92100 (A4VSG) or 92105 (A4CSG)
250/355	485	318.2	71	233	310.5	

Ports	Standard	Size	p _{max} [bar] ¹⁾	State ²⁾
X ₁ , X ₂	DIN 3852-1	M14 x 1.5; 12 deep (NG 125 and 180) M18 x 1.5; 12 deep (NG 250 and 355)	350 350	O O

1) Depending on the application, momentary pressure peaks can occur. Keep this in mind when selecting measuring devices and fittings.

2) O = Must be connected (plugged on delivery)
 X = Plugged (in normal operation)

HS5V(P) – control with internal control pressure supply for open circuit

Type	NG	40	71	125	180	250	355	450	500	750	1000	
A4VSO		●	●	●	●	●	●	–	–	–	–	HS5V(P)
A4VBO		–	●	●	–	●	–	–	–	–	–	

The variant **HS5V** corresponds to the HS5 design, but with internal control pressure supply, differential stroking pistons and depressurized basic setting $V_{g \max}$. This removes the need for an external control pressure supply. The control pressure supply takes place directly from the high pressure. With the electric motor switched off and actuator system depressurized, the pump swivels to maximum displacement ($V_{g \max}$) through spring force. For reliable control, the system pressure must be at least 20 bar.

If the pump is to be controlled below 20 bar, a preload block is required for generating the required control power. You need to contact us for a specific application.

► Optional (HS5VP): with pressure transducer

Basic position de-energized

With a de-energized proportional valve and plugged pump outlet, the pump switches to minimum pressure (6 to 10 bar).

Electronics:

► VT-HPC-1-1X, see data sheet 30237

Swiveling range –100 % to +100 %

As a special feature, the pump can switch the conveying direction. This feature of switching over the neutral position enables a quick pressure reduction via the pump.

▼ Dynamic characteristic curve for pressure reduction via the pump

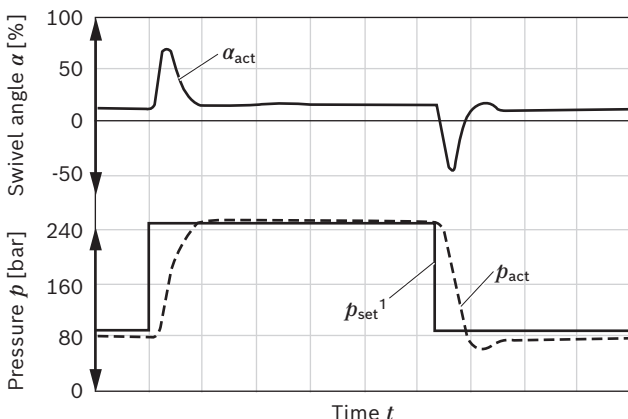

1) Due to the permissible data of the proportional valve

Technical data HS5V(P)

Size	NG	40 to 355
Maximum working pressure A4VSO $p_{\max}^{1)}$	bar	350
Nominal pressure A4VBO p_{nom}	bar	450
Minimum working pressure p_{min}	bar	20

Circuit diagram HS5V

▼ Sizes 250 and 355

Example: A4VSO HS5V with preload block AGEV4-05728-AA/46

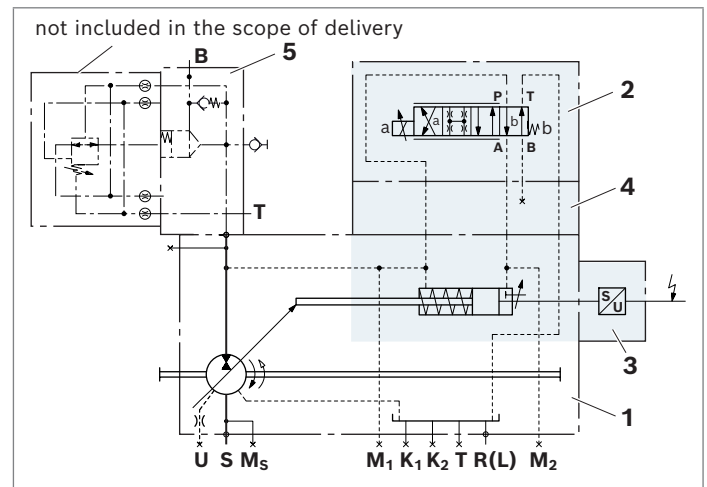

- 1 Pump with hydraulic control device
A4VSO (see data sheet 92050)
- 2 4/4 directional control valve (see data sheet 29027)

NG	Type
40 to 180	4WRPH6CA24L-2X/G24Z4/V-855
250 and 355	4WRPH6CA40L-2X/G24Z4/V-855

- 3 Inductive position transducer:

NG	Type
40, 125 and 180	AWAX004D03
71	AWAX004D02 and spacer
250 to 355	AWAX004D02

with round connector 4-pin M12 × 1

- 4 Intermediate plate
- 5 Preload block

To ensure the functional reliability for the HS5V(P) control system, the operating fluid must have a min. cleanliness level of 18/16/13 as defined in ISO 4406.

▼ **Sizes 71, 125, 250**

Example: A4VBO...HS5V, **sizes 71, 125, 250**

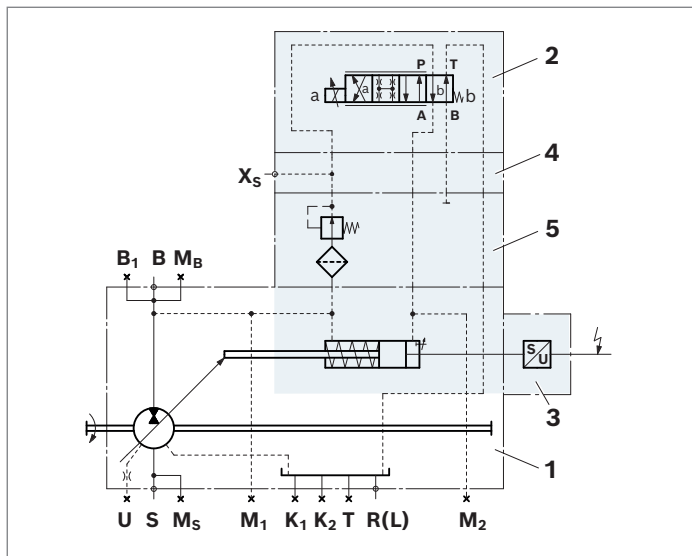

- 1 Pump with hydraulic control device
A4VBO (see data sheet 92122)
- 2 4/4 directional control valve (see data sheet 29027)

NG	Type
71 to 125	4WRPH6CA24L-2X/G24Z4/V-855
250	4WRPH6CA40L-2X/G24Z4/V-855

- 3 Inductive position transducer:

NG	Type
125	AWAX004D03
71	AWAX004D02 and spacer
250	AWAX004D02

with round connector 4-pin M12 × 1

- 4 Intermediate plate
- 5 Pressure relief valve

Dimensions HS5V

▼ **A4VSO, size 40 to 355**

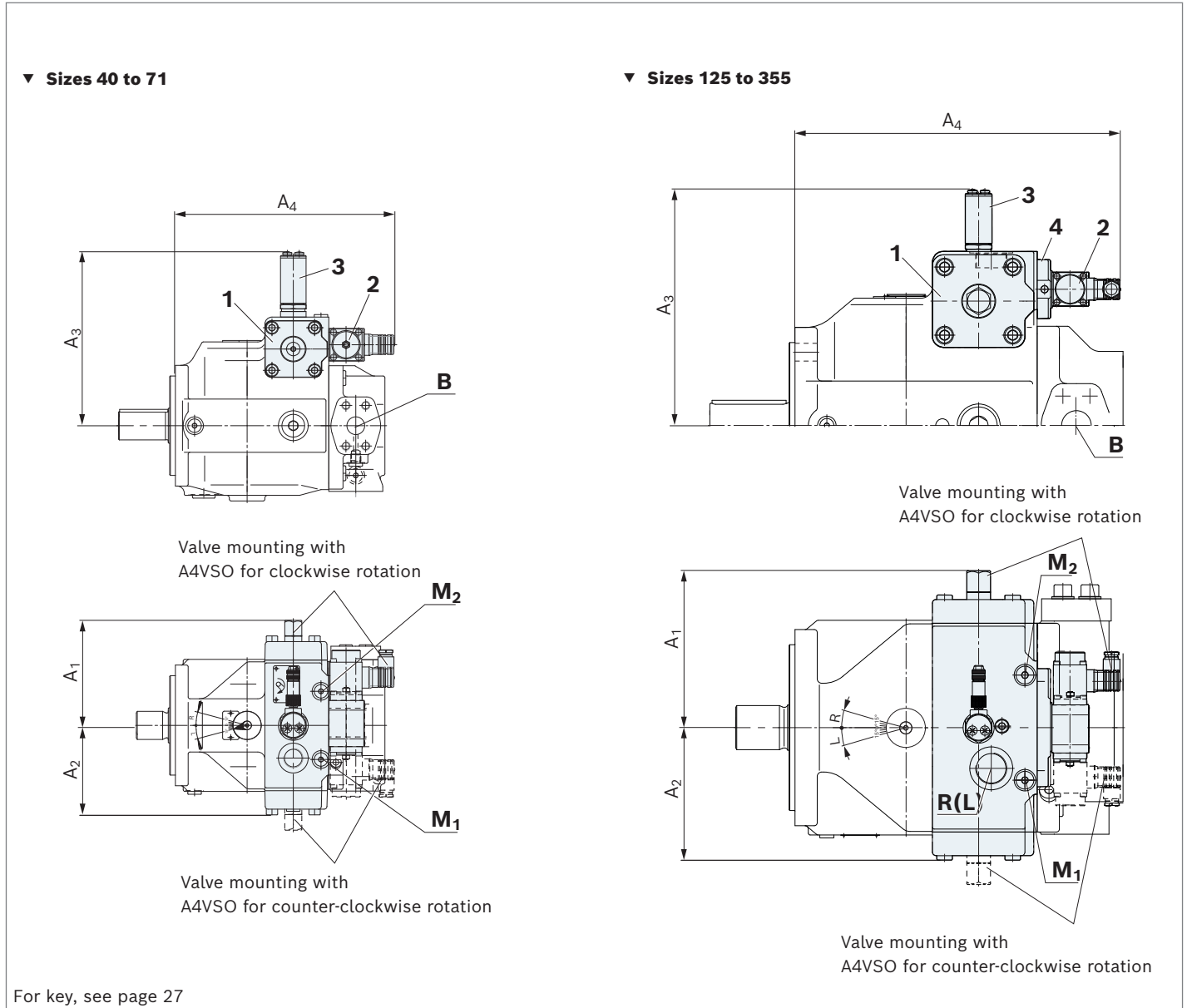

NG	A ₁	A ₂	A ₃	A ₄
40	130	104	224	281
71	148	126	244.7	309
125	177	147	271	375
180	177	147	271	375
250/355	212	179	309	433

For detailed dimensions and technical data of the variable pump, see data sheet 92050 (A4VSO)

Ports	Standard	Size	p_{max} [bar] ¹⁾	State ²⁾
M ₁ , M ₂	DIN 3852-1	M14 × 1.5; 12 deep (size 40 to 71) M18 × 1.5; 12 deep (size 125 to 355)	350	X

1) Depending on the application, momentary pressure peaks can occur. Keep this in mind when selecting measuring devices and fittings.

2) O = Must be connected (plugged on delivery)
 X = Plugged (in normal operation)

Dimensions HS5V

▼ **A4VBO, size 71**

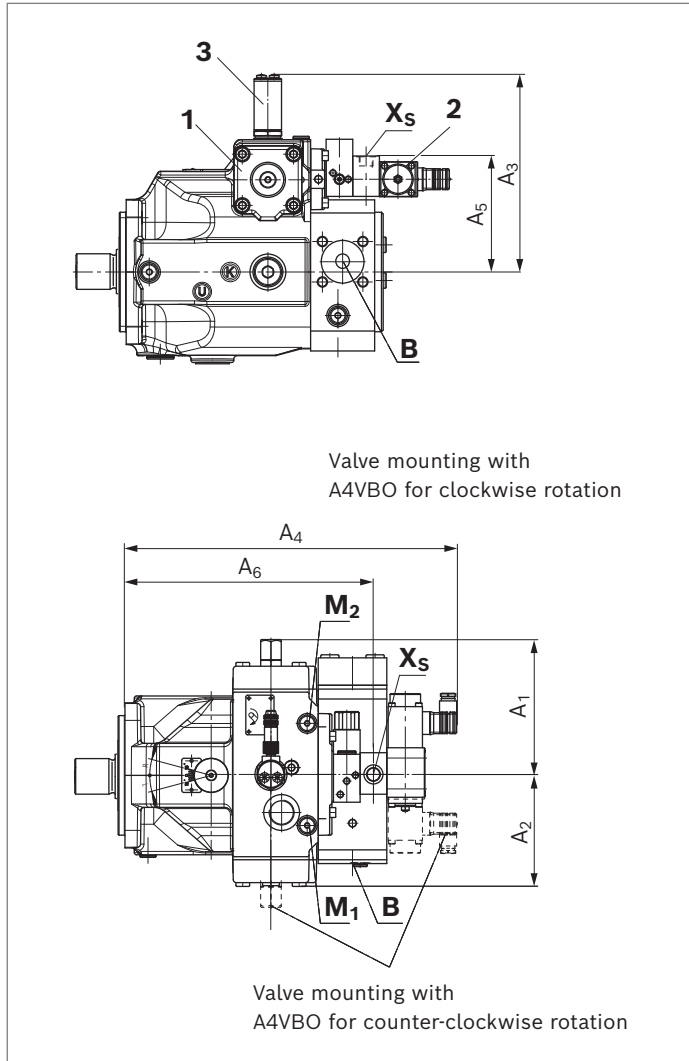

NG	A ₁	A ₂	A ₃	A ₄	A ₅	A ₆
71	148	126	244.7	378	144.2	268.5
125	On request					
250	On request					

For detailed dimensions and technical data of the variable pump, see data sheet 92122 (A4VBO)

Ports	Standard	Size	p_{max} [bar] ¹⁾	State ²⁾
M ₁ , M ₂	Control pressure measuring	DIN 3852-1 M14 × 1.5; 12 deep (size 40 to 71) M18 × 1.5; 12 deep (size 125 to 355)	350	X
X _s	External accumulator port	DIN 3852-1 M18 × 1.5; 12 deep	350	O

1) Depending on the application, momentary pressure peaks can occur. Keep this in mind when selecting measuring devices and fittings.

2) O = Must be connected (plugged on delivery)
 X = Plugged (in normal operation)

HS5L(P) – control with internal control pressure supply for A4CSG

Type	NG	250	355	500	750	
A4CSG		•	•	•	•	HS5L(P)

The **HS5L** variant corresponds to the HS5 version but with internal control pressure supply in the closed circuit. With a rotating pump and not active control (valve de-energized), the pump swivels to $-V_{g\ max}$ by the boost pressure. The control pressure supply takes place directly from the high pressure or boost pressure. This removes the need for an external control pressure supply. With the electric motor switched off and actuator system depressurized, the pump swivels to 0% swivel angle through spring-centering.

► Optional (HS5LP): with two pressure transducers

Notes

► The spring feedback in the controller and pump control spring centering are no safety devices. The controller can stick in an undefined position due to internal contamination (contaminated hydraulic fluid, abrasion or residual contamination from system components). As a result, the flow in the axial piston unit will no longer respond correctly to the operator's specifications. Check whether the application on your machine requires additional safety measures to bring the driven consumer to a safe position (immediate stop).

For safe control, the control pressure must be twice the boost pressure (for NG 355 +5 bar). See also boost pressures in data sheet 92105.

To ensure the functional reliability for the HS5L(P) control system, the operating fluid must have a min. cleanliness level of 18/16/13 as defined in ISO 4406. Further details and information on the required cleanliness level of the hydraulic fluid can be found in the operating instructions 92076-01-B.

Technical data HS5L(P)

Size	NG	250 to 750
Maximum working pressure $p_{max}^{1)}$	bar	350
Minimum working pressure p_{min}	bar	20
Minimum required control pressure	bar	Double boost pressure +5 bar for size 355

Circuit diagram HS5L

▼ Sizes 500 and 750

Example: A4CSG 500HS5L

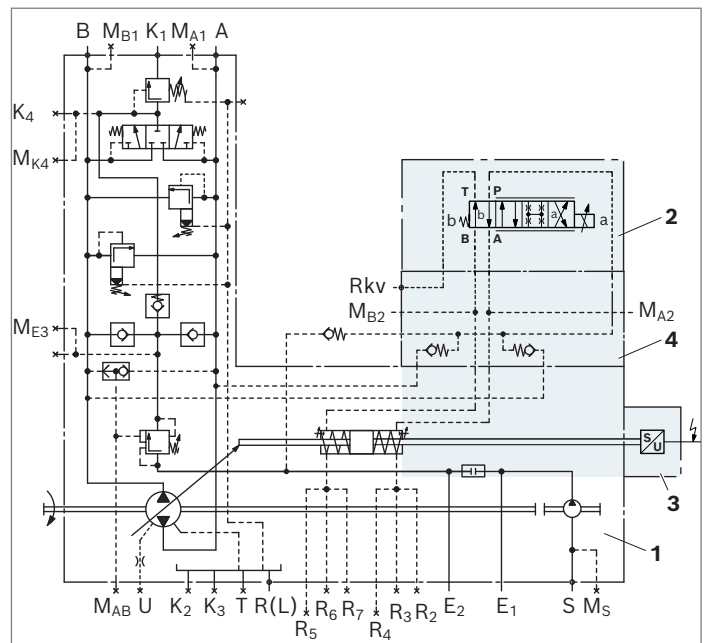

- 1 Pump with hydraulic control device A4CSG (see data sheet 92105)
- 2 4/4 directional control valve (see data sheet 29027)

NG	Type
250 and 750	4WRPH6CA40L-2X/G24Z4/V-855

- 3 Inductive position transducer:

NG	Type
250 to 750	AWAX004D02

with round connector 4-pin M12 × 1

- 4 Intermediate plate

▼ Flow direction in closed circuit

Direction of rotation	Swiveling range
clockwise	counter-clockwise
B to A	A to B clockwise
A to B	B to A counter-clockwise

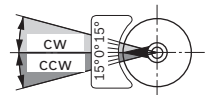

1) Due to the permissible data of the proportional valve, higher pressures on request

Dimensions HS5L

▼ **Size 250 to 355, example A4CSG HS5LP with two pressure transducers on port B and A**

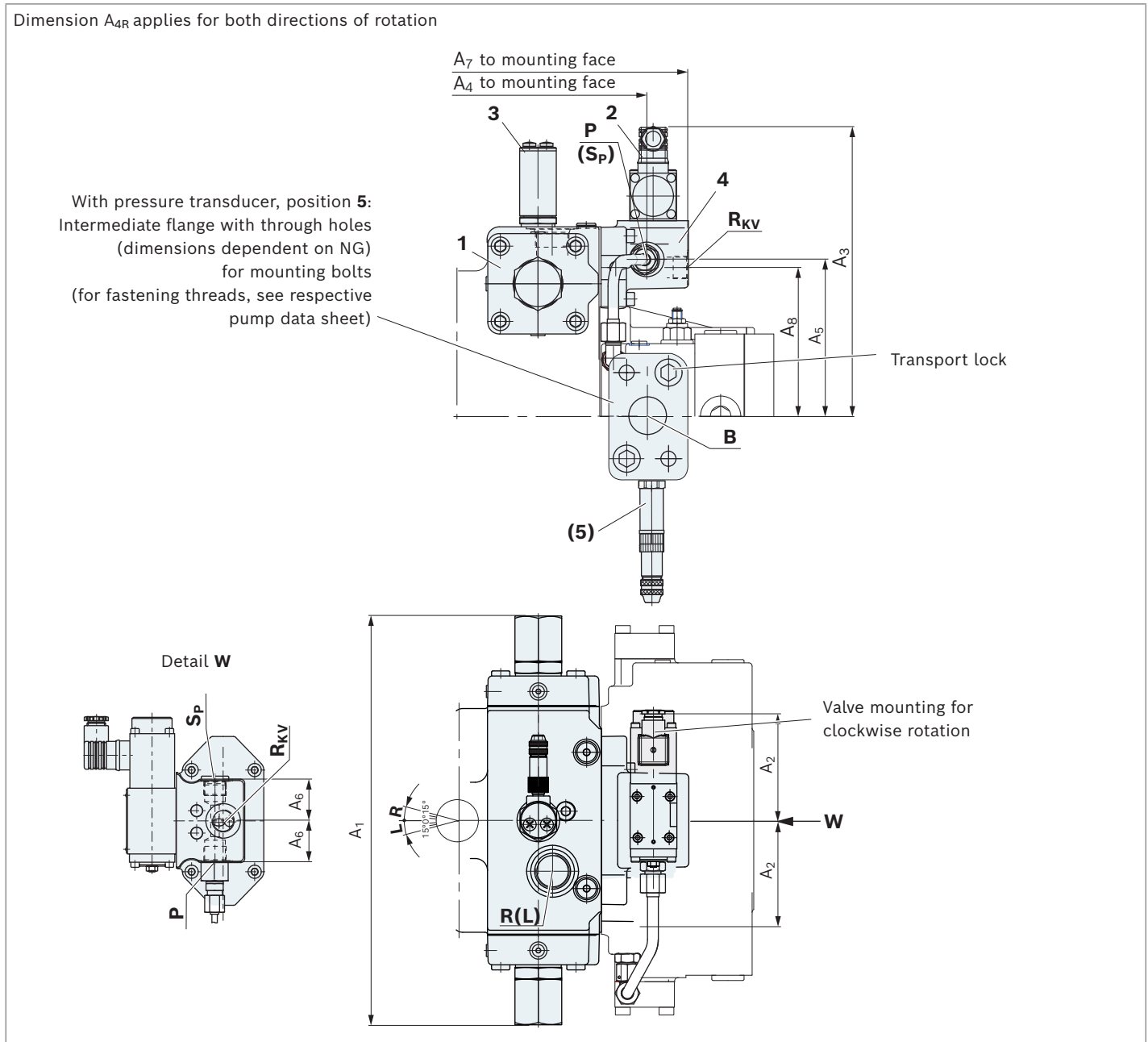

NG	A_1	A_3	A_4	A_5	A_6	A_7	A_8	
250/355	485	322	372	192	39	412	184	For detailed dimensions and technical data, see data sheet 92105

Ports	Standard	Size	p_{max} [bar] ¹⁾	State ²⁾
P	Control pressure	DIN 3852-1 M22 × 1.5; 14 deep	350	pip ed up
S_P	Control pressure accumulator	DIN 3852-1 M22 × 1.5; 14 deep	350	X
R_{KV}	Control fluid return flow	DIN 3852-1 M22 × 1.5; 14 deep	4	O
M₁, M₂	Control pressure measuring	DIN 3852-1 M18 × 1.5; 12 deep	350	X
R₂ ... R₇	Air bleeding the stroking chamber	DIN 3852-1 M10 × 1; 8 deep	350	X

The **R_{KV}** port must be unloaded to the reservoir.

1) Depending on the application, momentary pressure peaks can occur. Keep this in mind when selecting measuring devices and fittings.

2) O = Must be connected (plugged on delivery)
 X = Plugged (in normal operation)

Dimensions HS5L

▼ **A4CSG, sizes 500 to 750**

Example A4CSG HS5LP with two pressure transducers on ports **B** and **A**

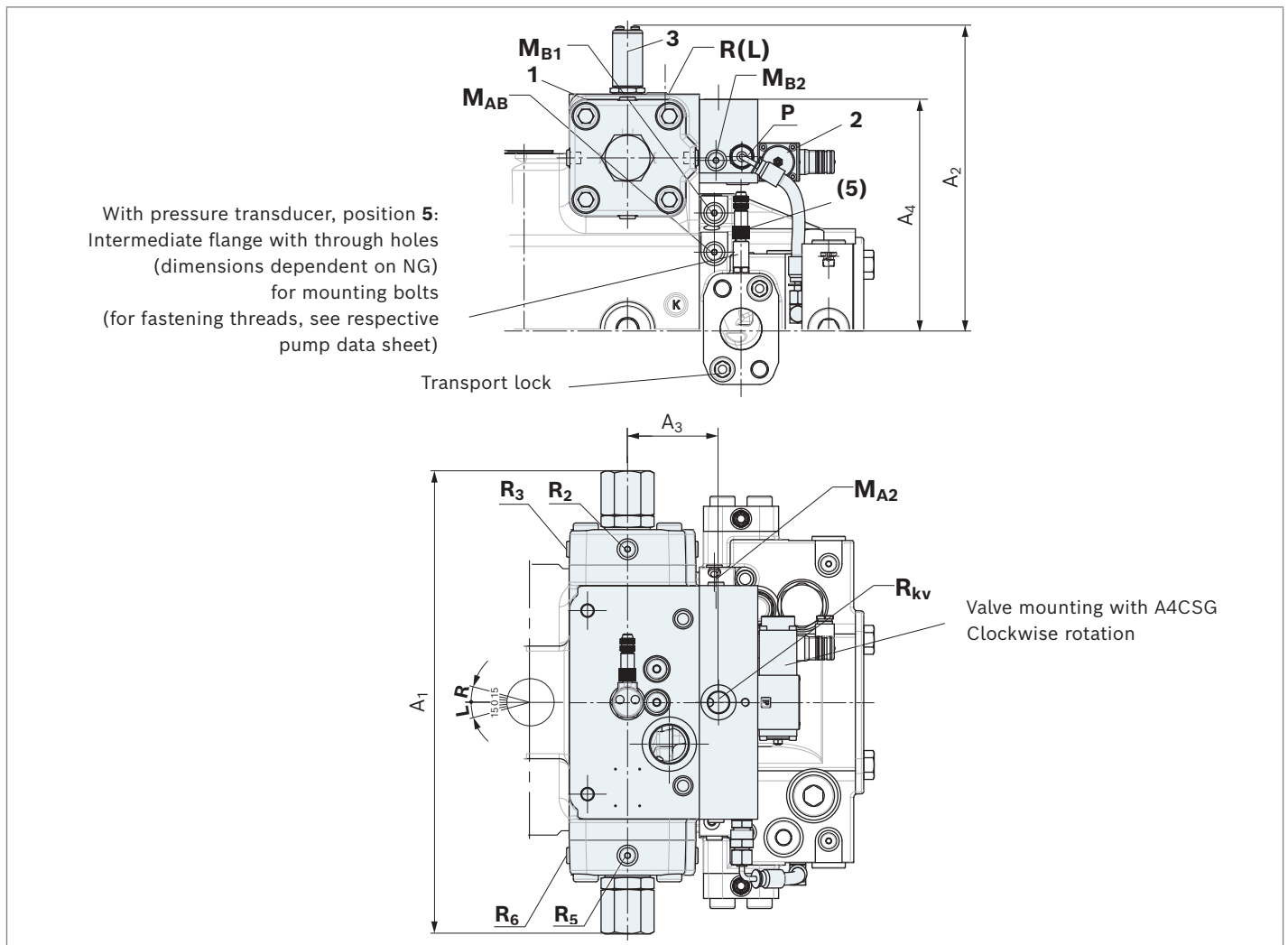

NG	A ₁	A ₂	A ₃	A ₄	
500	555	363	109	274	For detailed dimensions and technical data of the variable pump, see data sheet 92105 (A4CSG)
750	On request				

Ports		Standard ¹⁾	Size	p _{max} [bar] ¹⁾	State ²⁾
P	Control pressure	DIN 3852-1	M27 × 2; 16 deep	350	piped up
R_{KV}	Control fluid return flow	DIN 3852-1	M27 × 2; 16 deep	4	O
M_{A2}, M_{B2}, M_P	Control pressure measuring	DIN 3852-1	M14 × 1.5; 12 deep	350	X
R₂ ... R₇	Air bleeding the stroking chamber	DIN 3852-1	M14 × 1.5; 12 deep	350	X

The **R_{KV}** port must be unloaded to the reservoir.

1) Depending on the application, momentary pressure peaks can occur. Keep this in mind when selecting measuring devices and fittings.

2) O = Must be connected (plugged on delivery)
 X = Plugged (in normal operation)

HS5E(P) – control system with integrated digital electronics (OBE)

Type	NG	40	71	125	180	250	355	450	500	750	1000	
A4VSO		●	●	●	●	●	●	–	●	●	●	HS5E(P)
A4VSG		●	●	●	●	●	●	–	●	●	●	
A4CSG		–	–	–	–	●	●	–	●	●	–	
A4VBO		–	●	●	–	●	–	●	–	–	–	

An axial piston variable pump with HS5E is a complete solution for an entire Bosch Rexroth pump control system for electro-hydraulic

- ▶ Swivel angle control
 - ▶ Pressure control (optional HS5EP)
 - ▶ Torque limitation (optional HS5EP)
- and external control pressure supply.

The control system consists of the following components:

- ▶ A4VSO, A4VSG, A4CSG or A4VBO axial piston variable pump
 - ▶ Directional control valve with **On Board Electronics**
 - ▶ Swivel angle sensor for detecting pump swivel angle
 - ▶ Optional (HS5EP): one pressure transducer with A4VSO or two pressure sensors with A4VSG/A4CSG
- Machine and system dynamics must be optimized by the system operator using the pressure control function.

Spring-centering

Pump control spring centering comes standard. It is used for setting and adjustment in the depressurized neutral position, but without a defined reset during high-pressure operation. Spring centering is not a safety device. To minimize the control fluid consumption, the stroking chambers are sealed in sizes 125 to 1000 and can be bled via the ports R2 to R7.

Notes

- ▶ The pump control spring centering is not a safety device. The controller can stick in an undefined position due to internal contamination (contaminated hydraulic fluid, abrasion or residual contamination from system components). As a result, the flow in the axial piston unit will no longer respond correctly to the operator's specifications. Check whether the application on your machine requires additional safety measures to bring the driven consumer to a safe position (immediate stop).

Swivel angle limitation

Minimum and maximum swivel angle limitation is mechanically adjustable up to 50 % $V_{g \max}$.

For size 500, $V_{g \min}$ is adjustable up to 50 % $V_{g \max}$ and $V_{g \max}$ up to 70 % $V_{g \max}$.

Variable-speed operation

Variable-speed operation represents an additional function allowing the reduction of the rotational speed in the partial load range. This provides advantages in the noise behavior and total efficiency of the axial piston unit. In this variable-speed operating mode, depending on the current operating point, the optimum drive speed for the electric motor is calculated and passed on to the converter. For this purpose, it is essential that the electric drive motor has the appropriate dynamics and is controlled via a converter.

In the condition as delivered from the factory, the variable-speed operation is deactivated. If the control system shall work in variable-speed mode, this operating mode must be activated and parameterized (see data sheet 30237-Z).

Notes

Setting with A4VSO (open circuit):

- ▶ The $V_{g \max}$ stop is set to nominal $V_{g \max}$ as standard. Please specify different values in your order
- ▶ The $V_{g \min}$ stop is set to $V_g = 0$ l/min with $P_{HD} = 20$ bar as standard. Other values should be specified when placing the order.

For further technical data, see table "Technical data HS5(P)" on page 17.

To ensure the functional reliability for the HS5E(V)(L) control system, the operating fluid must have a min. cleanliness level of 18/16/13 as defined in ISO 4406.

Further details and information on the required cleanliness level of the hydraulic fluid can be found in the operating instructions 92076-01-B.

Electrical control loop performance

	Swivel angle control	Pressure control ¹⁾
Linearity tolerance	≤ 1.0%	≤ 1.5% (≤ 1.0% ²⁾)
Temperature error	≤ 0.5% / 10 K	≤ 0.5% / 10 K
Hysteresis	≤ 0.2%	≤ 0.2%
Repeat accuracy	≤ 0.2%	≤ 0.2%

Connection

- ▶ 24 V voltage supply
- ▶ Ambient temperature -20 °C to +60 °C
 Hydraulic fluid temperature -20 °C to +70 °C
- ▶ LED status indicator
- ▶ Interface for:
 EtherNet/IP, Sercos III, EtherCAT,
 ProfiNET RT connection

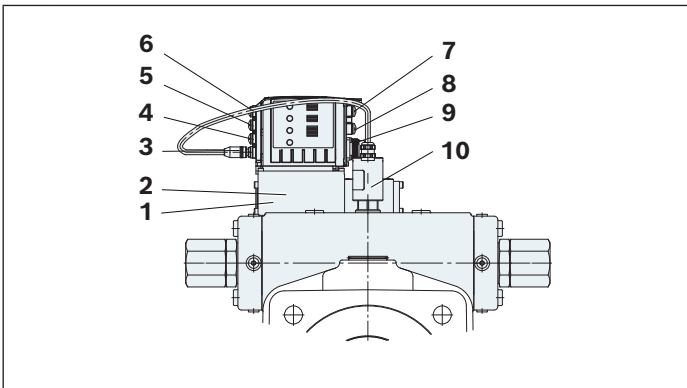

Example A4VS size 250

1	Proportional solenoid
2	Inductive position transducer for valve position
3	X8A actual swivel angle input
4	Reserved, X2N
5	Configurable sensor interface X2M2 (Pressure sensor input)
6	Configurable sensor interface X2M1 (Pressure sensor input)
7	Multi-EtherNet interface X7E1
8	Multi-EtherNet interface X7E2
9	Plug-in connector XH4
10	VT-SWA-LIN-G15 swivel angle sensor

1) Without taking into account the pump pulsation
 2) Using the integrated calibration function

Circuit diagrams HS5EP

▼ Sizes 125 to 500

Example: A4VSO...HS5EP (with pressure transducer)

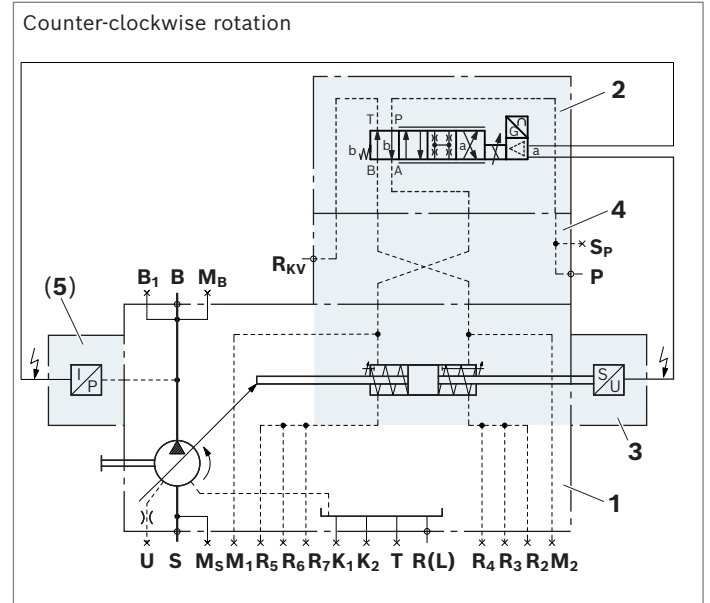
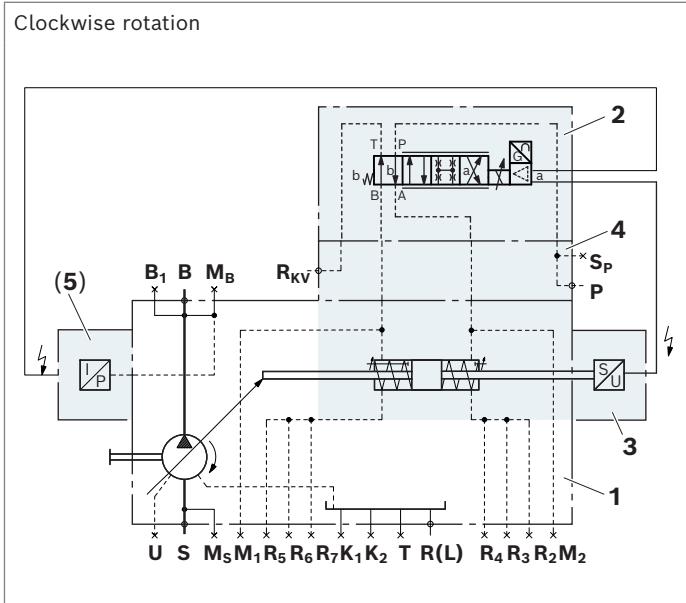

- 1 Pump with hydraulic control device
A4VSO (see data sheet 92050), A4VBO (see data sheet 92122)
- 2 Pilot control valve HS5E
- 3 Swivel angle sensor VT-SWA-LIN-1X/G15-...-C20
- 4 Intermediate plate
- 5 **Only with HS5EP:** Pressure transducer HM20-2X/630-C-K35 (see data sheet 30272) with intermediate flange, with A4VSG and A4CSG, each pressure side has 1 pressure transducer assigned and mounted

Connection table HS5E

Ports	
S	Suction port
B	Working port
P	Control pressure
Sp	Control pressure accumulator
R_{KV}	Control fluid return flow
M₁, M₂	Control pressure measuring
R₂ ... R₇	Air bleeding the stroking chamber
M_S	Suction pressure measuring
M_B	Measuring operating pressure
K₁, K₂	Flushing port
T	Drain port
R(L)	Fluid filling; air bleeding (drain port)
U	Flushing port
B₁	Additional connection

Electrical data of pilot control valve HS5E

Ambient and operating conditions

Characteristics			Values
Supply voltage ¹⁾	Nominal voltage	U_B	24 VDC
	Lower limit value	$U_B(t)_{\min}$	18 VDC
	Upper limit value	$U_B(t)_{\max}$	36 VDC
	maximum permissible residual ripple		2.5 Vss
Power consumption	maximum	P	40 W
Required external fuse protection			4 A, slow-blow
AD/DA resolution	Analog inputs	Bit	12
	Analog outputs	Bit	10
Actual pressure value input XH4 PIN 10 and 11 (With configuration to current input, maximum permissible input current 30 mA.)	Analog voltage	V	0 to 10
	Analog current	mA	0 to 20
Ambient temperature range at the pump		ϑ	0 to +60 °C
Storage temperature range pump/electronics	permissible		+5 to +40 °C
Hydraulic fluid temperature			-20 to +70 °C
Cleanliness level of hydraulic fluid	according to ISO 4406 for particle size 4/6/14 μm		18/16/13

Environmentally acceptable systems for the areas of EMC, climate, and mechanical loading

Characteristics	Values
Mechanical loading: Sinus test according to DIN EN 60068-2-6	10 ... 2000 Hz / maximum 10g / 10 cycles / 3 axes
Mechanical loading: Noise check according to DIN EN 60068-2-64	20 ... 2000 Hz / 10g RMS / 30g peak / 30 min / 3 axes
Mechanical loading: Transport shock according to DIN EN 60068-2-27	15g / 11 ms / 3 axes
Electromagnetic compatibility (EMC)	
▶ EN 61000-6-2 / EN 61000-6-3 – EN 61000-4-2 ESD – EN 61000-4-4 burst – EN 61000-4-5 surge – EN 61000-4-6 HF line-conducted – EN 55016-2-1 radio interference voltage	10 kV CD/15 kV AD with BWK B 2 kV with BWK B 0.5 kV (sym./asym.) with BWK B 10 Veff (150 kHz ... 80 MHz) with BWK A 0.15 ... 30 MHz, Class A, EN 55022
Maximum relative humidity (non-condensing)	95%
Design of electronics	Integrated on pilot valve (OBE)
Electrical connection	see following page 39
Type of protection according to EN 60529 (pump including pilot valve and sensors)	IP 65 with mounted and locked plug-in connectors

Notes

- ▶ The information about mechanical loading only refers to components containing electronics, i.e. the HS5E pilot control valve, HM20 and the VT-SWA-LIN.

¹⁾ Supply voltage is used directly for sensor connections **X2M1**, **X2M2**, and **X2N** (no internal voltage limitation)

XH4: Signals and pin assignment of the central connector

The following table shows the pin assignment of the central connector 11 + PE for pilot control valve HS5E.

The "code" column refers to the cable kit that can be ordered as optional accessories.

(For cable sets, see instruction manual 92076-01-B chapter "Cable sets")

▼ XH4: Central connector

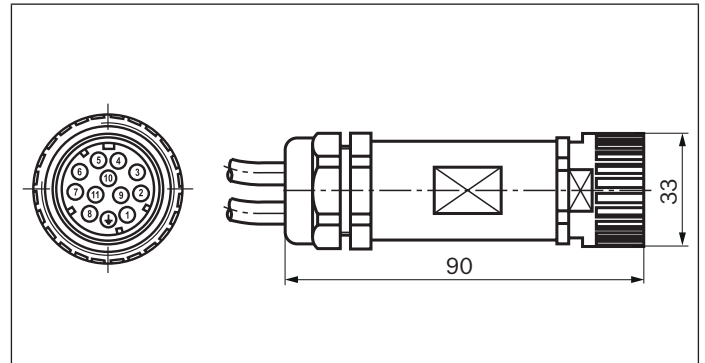

Pin	Signal	Description	Signal direction	Signal level	Code
1	+ U _B	Voltage supply	IN	+24 V	1
2	L0	Reference potential for voltage supply	-	-	2
⊕	Ground	Ground connection for the electronics	-	-	Yellow/ green
3	DO	Switching output 24 V, max. 1.5 A Factory setting: Error signal	OUT	Logical 24 V (Load I _{max} ≤ 50 mA)	white
4	M0	Reference potential for analog signals	-	-	yellow
5	AI 2	Analog input 2 (or digital input, configuration via software) factory setting: Swivel angle setpoint value standardized	IN	analog +/-10V (digital 24V)	green
6	AO 2	Analog output 2 factory setting: Swivel angle actual value standardized	OUT	+/- 10V or 0...20 mA ¹⁾ (Load I _{max} ≤ 1 mA)	Violet
7	AI 1	Analog input 1 (or digital input, configuration via software) Factory setting: Pressure setpoint value standardized	IN	+/- 10 V or 24 V digital	Pink
8	AO 1	Analog output 1 factory setting: Actual pressure value standardized	OUT	+/- 10V or 0...20 mA ¹⁾ (Load I _{max} ≤ 1 mA)	red
9	DI	Digital input (use can be freely configured) Factory setting: Error reset	IN	Logical 24 V	Brown
10	Actual pressure value High	Pressure sensor input: Signal level dependent on parameter setting.	IN	0-10 V, 0-20 mA (freely configurable)	Black
11	Actual pressure value Low	Reference potential for actual pressure value High (pin 10)	-	-	blue
n.c.					gray

Notice

- ▶ Connect ports M0 and L0 in the control cabinet to prevent potential shifts.
- ▶ Signal lines (pin 3 to 11) must be shielded. The shielding must be connected to the control on one side!

1) If the analog inputs AI1 and AI2 are not used, the analog outputs AO1 and AO2 can be parameterized as current outputs (e.g. if the setpoint value is specified via the fieldbus).

X2M1 and X2M2: Analog, configurable pressure sensor interface (coding A), M12, 5-pin, socket

Pin assignment of X2M1 and X2M2

Pin	Assignment
1	+ 24 V voltage output (sensor supply) ¹⁾
2	Sensor signal input for current (4 ... 20 mA) ²⁾
3	GND
4	Sensor signal input voltage (0 ... 10V) ²⁾
5	Negative differential amplifier input to pin 4 (optional)

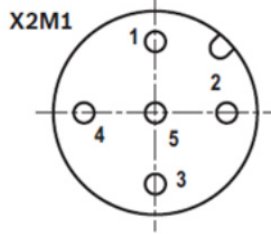

X7E1 and X7E2: Plug-in connector assignment for Ethernet interface (coding D), M12, 4-pin, socket

Pin assignment of X7E1 and X7E2

Pin	Assignment
1	TxD +
2	RxD +
3	TxD -
4	RxD -
5	not assigned

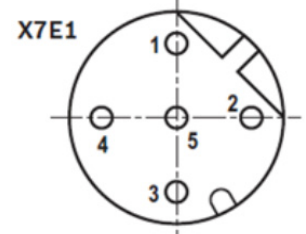

- ▶ Use a shielded bus cable as the data cable. When doing this, the shield should be connected to the connector housing.
- ▶ Ethernet M12 connection cable, please contact Rexroth for the material number.

Voltage supply of the HS5E pilot control valve

The HS5E pilot control valve is supplied with 24 V DC. If this system-side voltage supply is not present, you can use the T-NE30-2X/ power supply unit according to data sheet 29929. You connect the 24 V of the power supply unit to connections 1 (+24 V) and 2 (L0) of the plug-in connector.

With the available connection cable, this corresponds to the two black wires of the 1 mm² cross section 3-pole cable. In this context, you must connect the wire labeled "1" to +24 V and the one labeled "2" to L0 (Ground). The yellow/green wire must be connected to ground.

Connecting the voltage supply of the HS5E pilot control valve Recommendation.

On the system-side, the voltage supply of the HS5E pilot control valve should be fuse-protected using a 4 A slow-blow fuse.

The HS5E pilot control valve does not have an enable input to block the function of the valve.

In the event of a fault, the drive enable should be canceled via fieldbus. All other safety-relevant intervention must be carried out by the higher-level control (e.g. drive motor OFF, close isolator valves, etc.)

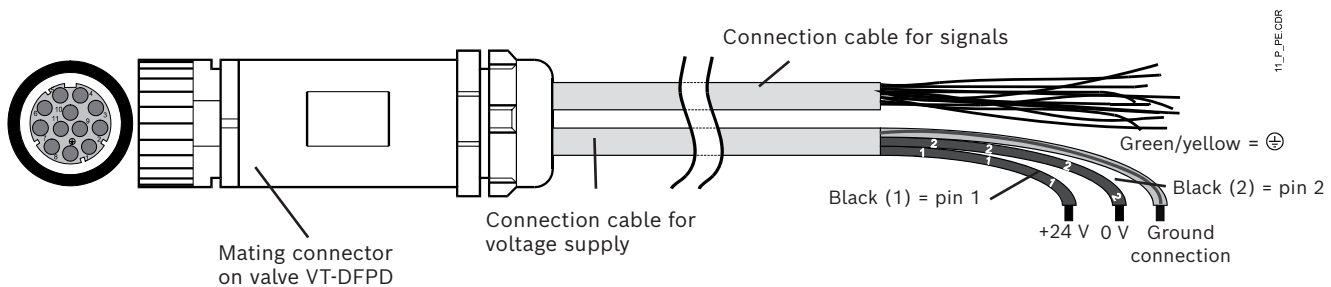

1) Maximum load capacity 50 mA, voltage output same as connected voltage supply at input XH4.
2) Only one signal input per interface can be configured

LED status indicators

LED	Interface	Sercos	EtherNET/IP	EtherCAT	PROFINET
1	X7E1	Activity	Activity	not used	Activity
2		Link	Link	Link/Activity	Link
3	Electronics- module	S	Network status	Network status	Network status
4		Module status	Module status	Module status	Module status
5	X7E2	Activity	Activity	not used	Activity
6		Link	Link	Link/Activity	Link

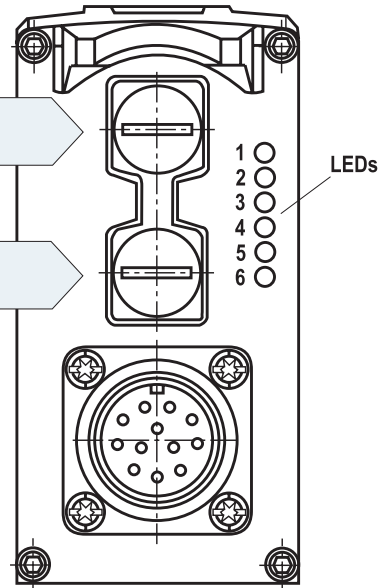

Indicators of status LEDs

Module status LED (LED 4)	Indication status	Network status LED	Indication status
Off	No voltage supply	Off	No voltage supply
Green/red flashing	Self-test	Green	Operation
Green flashing	Drive ready for operation		
Green	in control		
Red flashing	Warning		
Red	Fault		

- ▶ LEDs 1, 2, 5, and 6 refer to interfaces "X7E1" and "X7E2"
 - Link: Cable is plugged in, connection has been established (lit up permanently)
 - Activity: Data has been sent/received (flashing)
- Module status LEDs 3 and 4 refer to the electronics module.
- For a detailed description of the diagnosis LEDs, refer to the functional description of the Rexroth HydraulicDrive.

Dimensions HS5E(P)

▼ **A4VSO, size 40 to 71, example: A4VSO HS5EP with pressure transducer in B** (clockwise rotation with; counter-clockwise without HM20)

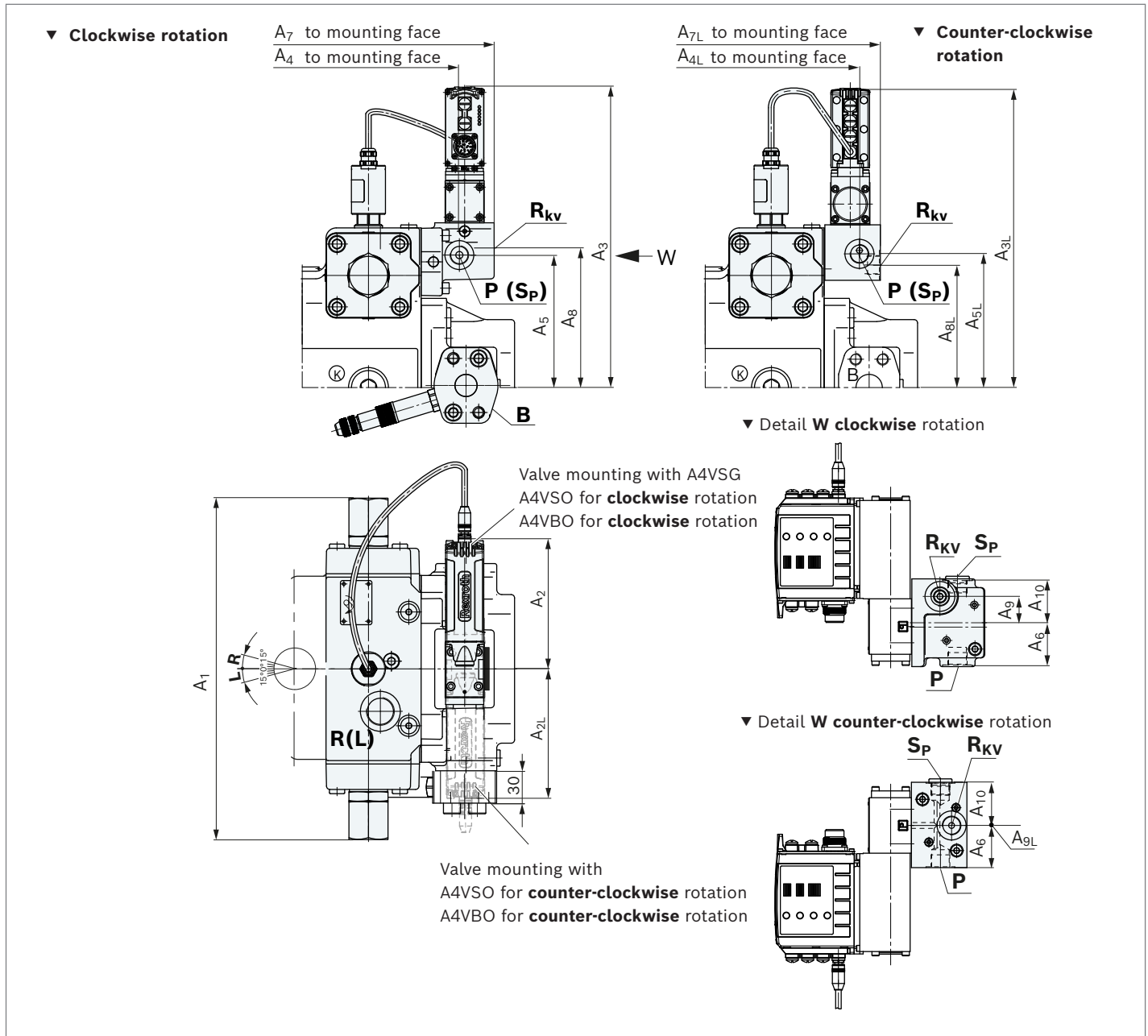

NG	A ₁	A ₂	A _{2L}	A ₃	A _{3L}	A ₄	A _{4L}	A ₅	A _{5L}	A ₆	A ₇	A _{7L}	A ₈	A _{8L}	A ₉	A _{9L}	A ₁₀
40	296	164	166	319.7	301	222	229.5	108	107	48	273	253	128	94	30	0	48
71	332	159.3	161	335	318	249	256.5	123	122	48.4	300	280	143	109	30	0	49.6

For detailed dimensions and technical data of the variable pump, see data sheet 92050 (A4VSO)

Ports	Standard	Size	p _{max} [bar] ¹⁾	State ²⁾
P, SP	Control pressure	DIN 3852-1 M22 × 1.5; 14 deep	350	O
R _{KV}	Control fluid return flow	DIN 3852-1 M22 × 1.5; 14 deep	4	O

The **R_{KV}** port must be unloaded to the reservoir.

1) Depending on the application, momentary pressure peaks can occur. Keep this in mind when selecting measuring devices and fittings.

2) O = Must be connected (plugged on delivery)
X = Plugged (in normal operation)

Dimensions HS5E(P)

▼ **A4VSO, sizes 125 to 355**

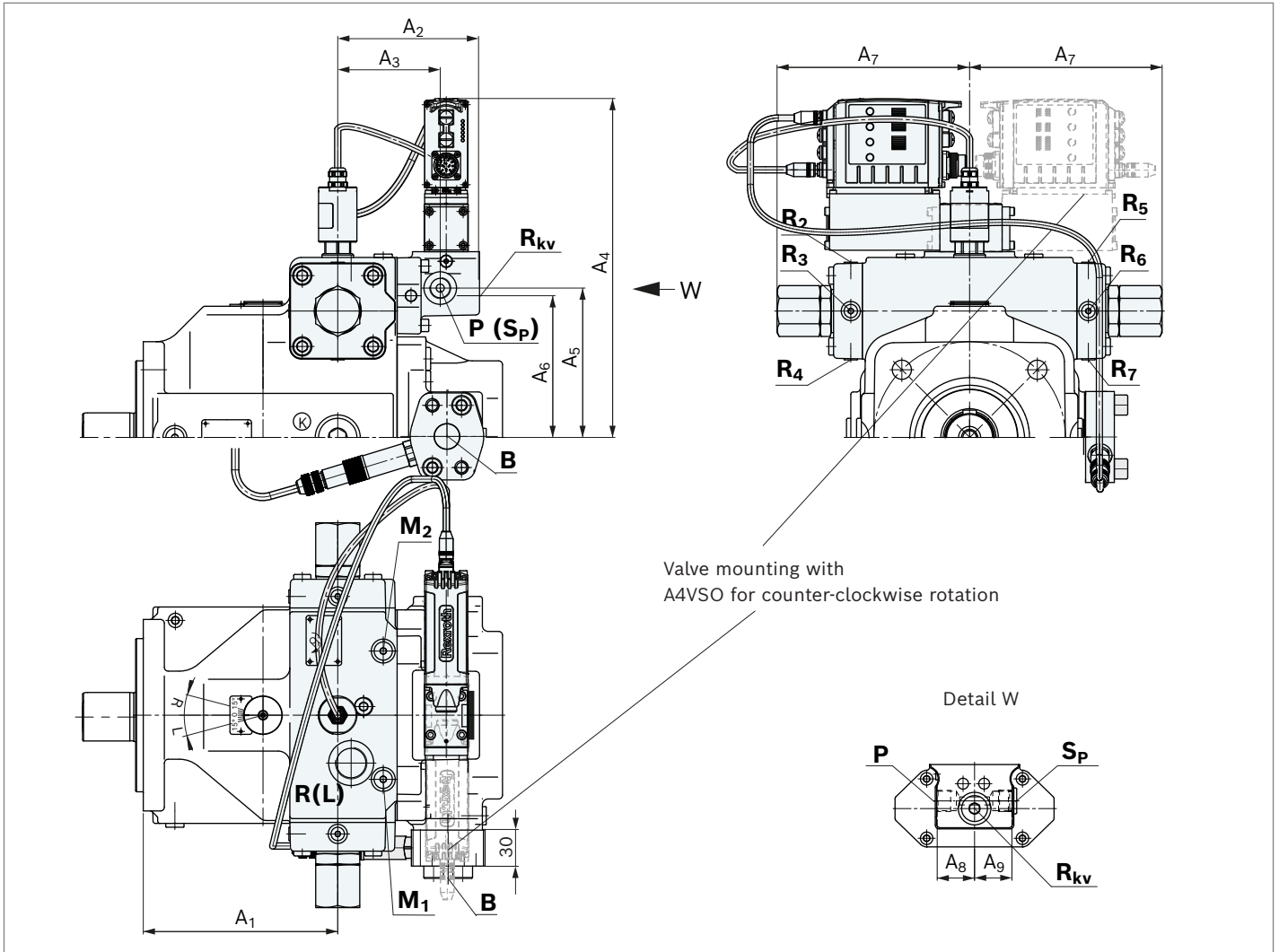

NG	A ₁	A ₂	A ₃	A ₄	A ₅	A ₆	A ₇	A ₈	A ₉	
125	203	147	107	343	156	148	177	39	39	For detailed dimensions and technical data of the variable pump A4VSO, see data sheet 92050
180	203	147	107	354	156	148	201	39	39	
250	248	164	124	379	192	184	242.5	39	39	
355	248	164	124	379	192	184	242.5	39	39	

Ports	Standard	Size	p_{max} [bar] ¹⁾	State ²⁾
M ₁ , M ₂	Control pressure measuring	DIN 3852-1	M14 x 1.5; 12 deep (NG 125 and 180) M18 x 1.5; 12 deep (NG 250 and 355)	X
P, SP	Control pressure	DIN 3852-1	M22 x 1.5; 14 deep	O
R ₂ ... R ₇	Air bleeding the stroking chamber	DIN 3852-1	M14 x 1.5; 8 deep	X
R _{KV}	Control fluid return flow	DIN 3852-1	M22 x 1.5; 14 deep	O

The **R_{KV}** port must be unloaded to the reservoir.

1) Depending on the application, momentary pressure peaks can occur. Keep this in mind when selecting measuring devices and fittings.

2) O = Must be connected (plugged on delivery)
X = Plugged (in normal operation)

Dimensions HS5E(P)

▼ **A4VSO, sizes 500 to 1000**

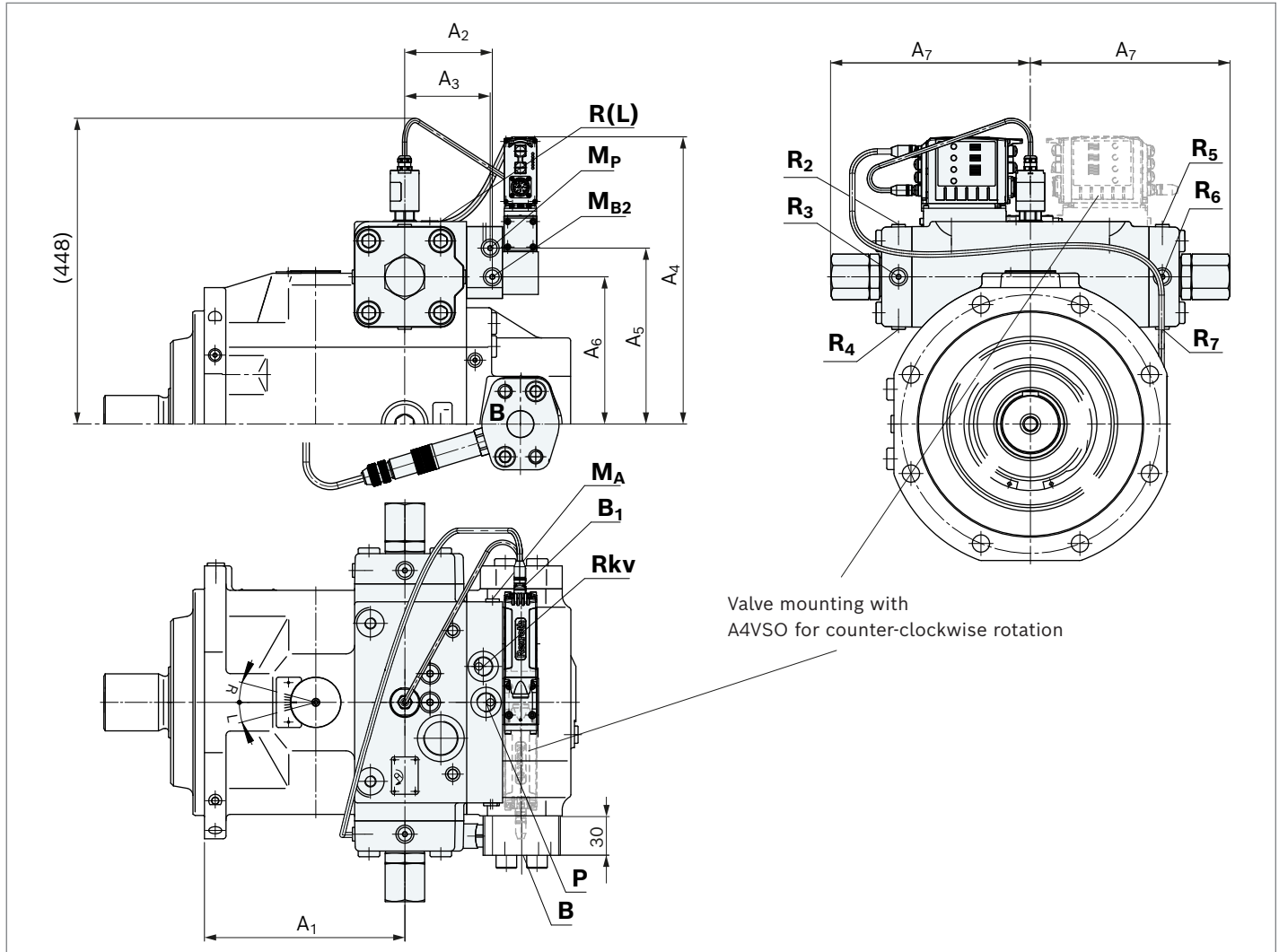

NG	A ₁	A ₂	A ₃	A ₄	A ₅	A ₆	A ₇	
500	279	122	119	400	245	205	277.5	For detailed dimensions and technical data of the variable pump, see data sheet 92050 (A4VSO)
750	On request							
1000	On request							

Ports	Standard	Size	p_{max} [bar] ¹⁾	State ²⁾
M _{B1}	Control pressure measuring	DIN 3852-1 M18 × 1.5; 12 deep	350	X
M _{B2} , M _A , M _P	Control pressure measuring	DIN 3852-1 M14 × 1.5; 12 deep	350	X
P	Control pressure	DIN 3852-1 M27 × 2; 16 deep	350	O
R ₂ ... R ₇	Air bleeding the stroking chamber	DIN 3852-1 M14 × 1.5; 12 deep	350	X
R _{KV}	Control fluid return flow	DIN 3852-1 M27 × 2; 16 deep	4	O

The **R_{KV}** port must be unloaded to the reservoir.

1) Depending on the application, momentary pressure peaks can occur. Keep this in mind when selecting measuring devices and fittings.

2) O = Must be connected (plugged on delivery)
X = Plugged (in normal operation)

HS5EV(P) – control supply with integrated digital electronics (OBE) and internal control pressure supply

Type	NG	40	71	125	180	250	355	500	750	1000	
A4VSO		•	•	•	•	•	•	–	–	–	HS5EV(P)
A4VBO		–	•	•	–	•	–	–	–	–	

An axial piston variable pump with HS5E control system is a complete solution for an entire Bosch Rexroth pump control system for an electro-hydraulic

- ▶ Swivel angle control
 - ▶ pressure control (optional HS5EVP)
 - ▶ torque limitation (optional HS5EVP)
- with internal control pressure supply.

The control system consists of the following components:

- ▶ A4VSO or A4VBO axial piston variable pump
- ▶ Directional control valve with **On Board Electronics**
- ▶ Swivel angle sensor for detecting pump swivel angle
- ▶ Optional (HS5EVP): one pressure transducer with A4VSO and A4VBO

Machine and system dynamics must be optimized by the system operator using the pressure control function. In contrast to the HS5E control system, the HS5EV control system eliminates the need for an external control pressure supply. The control pressure supply takes place directly from the high pressure.

With the electric motor switched off and actuator system depressurized, the pump swivels to maximum displacement ($V_{g \max}$) through spring force.

For reliable control, the system pressure must be at least 20 bar.

If the pump is to be controlled below 20 bar, a preload block is required for generating the required control power. You need to contact us for a specific application.

Property, basic position de-energized

With the proportional valve de-energized, the pump outlet plugged and the axial piston unit rotating, a minimum pressure (approx. 6 to 10 bar) settles.

Swiveling range –100 % to +100 %

As a special feature, the pump can switch the conveying direction. This feature of switching over the neutral position enables a quick pressure reduction via the pump.

▼ Dynamic characteristic curve for pressure reduction via the pump

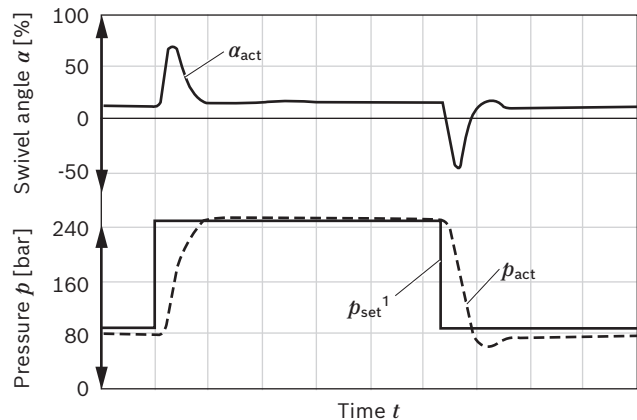

Technical data: Working pressure HS5E control system

Size	NG	40 to 355	
Maximum working pressure A4VSO	$p_{\max}^{1)}$	bar	350
Nominal pressure A4VBO	p_{nom}	bar	450
Minimum working pressure	p_{\min}	bar	20

Electrical control loop performance

	Swivel angle control	Pressure control ¹⁾
Linearity tolerance	$\leq 1.0\%$	$\leq 1.5\%$ ($\leq 1.0\%^{2)}$)
Temperature error	$\leq 0.5\%$ / 10 K	$\leq 0.5\%$ / 10 K
Hysteresis	$\leq 0.2\%$	$\leq 0.2\%$
Repeat accuracy	$\leq 0.2\%$	$\leq 0.2\%$

Notes

- ▶ Information on electrical data and ambient and operating conditions of the pilot control valve as well as further information on the central connector can be found on page 38 and 39.

To ensure the functional reliability for the HS5EV(P) control system, the operating fluid must have a min. cleanliness level of 18/16/13 as defined in ISO 4406. Further details and information on the required cleanliness level of the hydraulic fluid can be found in the operating instructions 92076-01-B.

1) Due to the permissible data of the proportional valve with consideration of the pump pulsation
 2) Using the integrated calibration function

Connection

- ▶ 24 V voltage supply
- ▶ Ambient temperature -20 °C to +60 °C
 Hydraulic fluid temperature -20 °C to +70 °C
- ▶ LED status indicator
- ▶ Interface for:
 EtherNet/IP, Sercos III, EtherCAT,
 ProfiNET RT connection

For further technical information see HS5E

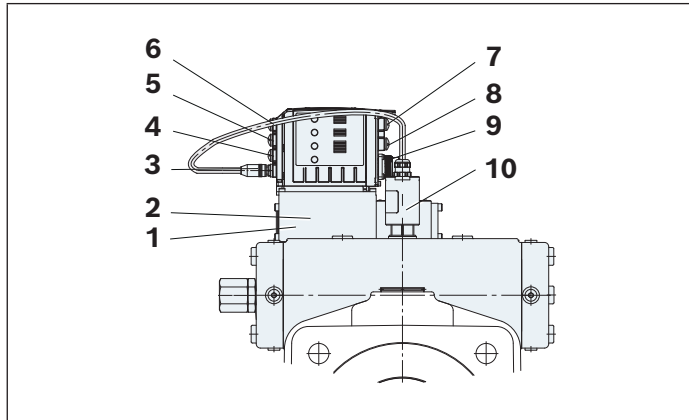

Example: A4VSO size 250, clockwise rotation

1	Proportional solenoid
2	Inductive position transducer for valve position
3	X8A actual swivel angle input
4	reserved, X2N
5	Configurable sensor interface X2M2 (Pressure sensor input)
6	Configurable sensor interface X2M1 (Pressure sensor input)
7	Multi-EtherNet interface X7E1
8	Multi-EtherNet interface X7E2
9	Plug-in connector XH4
10	VT-SWA-LIN-G15 swivel angle sensor

Sectional view of A4VSO...HS5EV(P)

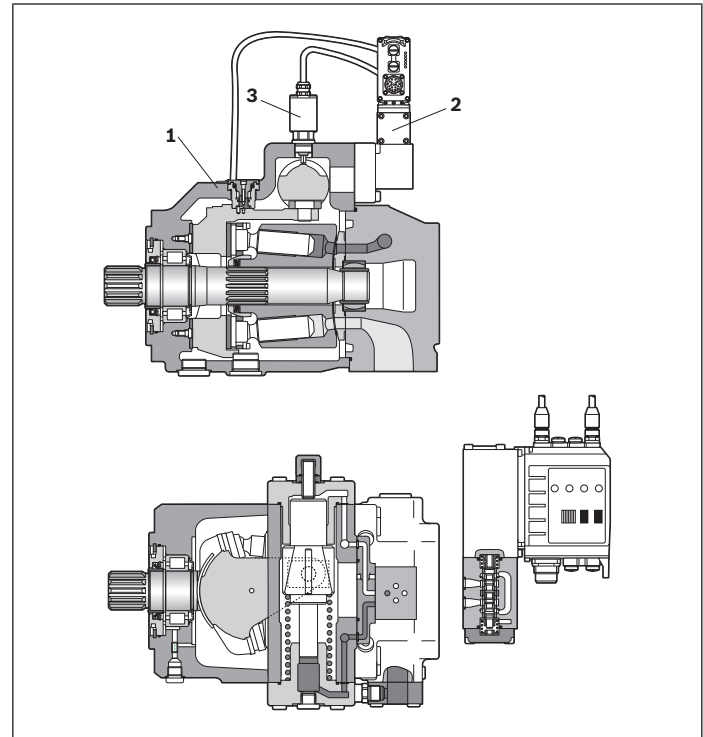

- 1 Pump A4VSO with hydraulic control device
(see data sheet 92050)
- 2 HS5E pilot control valve

NG	Type
40 to 180	HS5EN/6 CA 24L-2X/VH0/24MD7G
250 and 355	HS5EN/6 CA 40L-2X/VH0/24MD7G

- 3 Swivel angle sensor (see data sheet 30263):

NG	Type
40, 125 and 180	VT-SWA-LIN-1X/G15-1-C20
71	VT-SWA-LIN-1X/G15-2-C20
250 to 1000	VT-SWA-LIN-1X/G15-3-C20

with round connector 4-pin M12 × 1

Preferred types		
R902564081	A	A4VSO 40 HS5EV/10R-PZB13N00
R902569938	A	A4VSO 71 HS5EV/10R-PZB13N00

Optional:

- ▶ HS5EVP with a pressure transducer for pressure control and torque limitation

System circuit diagram HS5EVP

▼ **A4VSO, size 40 to 355**

Example: A4VSO 250HS5EVP with preload block AGEV

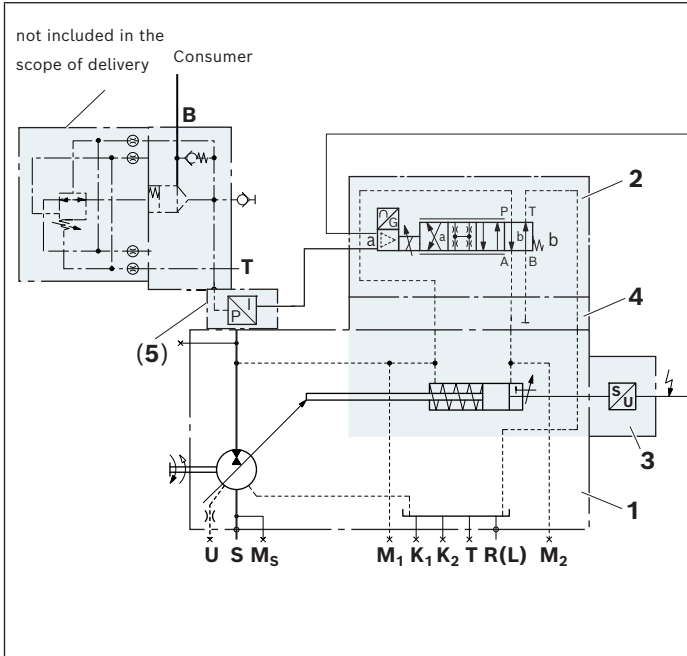

Ports

S	Suction port
B	Working port
M_1, M_2	Control pressure measuring
M_s	Suction pressure measuring
K_1, K_2	Flushing port
T	Drain port
R(L)	Fluid filling; air bleeding (drain port)
U	Flushing port

Circuit diagram HS5EVP

▼ **Sizes 40 to 355**

Example: A4VSO...HS5EVP (with pressure transducer)

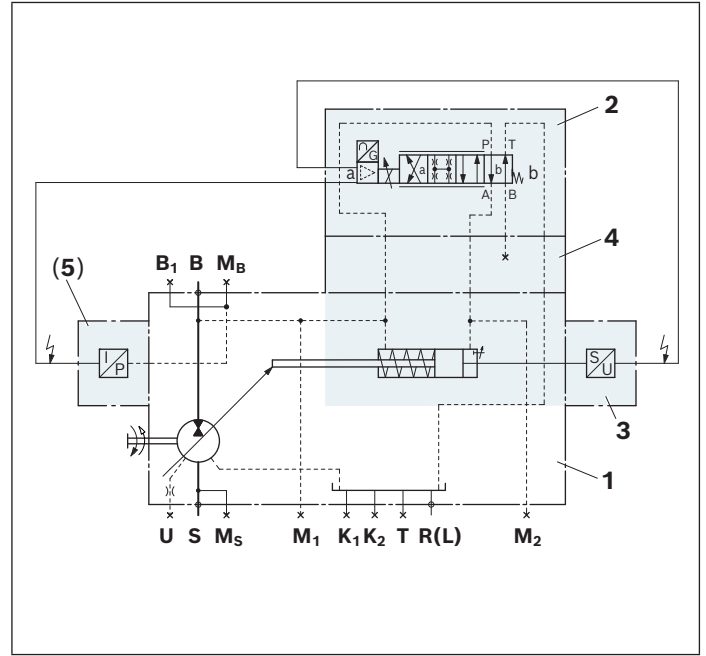

- 1 Pump with hydraulic control device
A4VSO (see data sheet 92050), A4VBO (see data sheet 92122)
- 2 Pilot control valve HS5E
- 3 Swivel angle sensor VT-SWA-LIN-1X/G15-...-C20
- 4 Intermediate plate
- 5 **Only with HS5EVP:** Pressure transducer HM20-2X/630-C-K35 (see data sheet 30272) with intermediate flange.

Circuit diagram HS5EVP▼ **Sizes 71 to 250**

Example: A4VBO...HS5EVP (with pressure transducer)

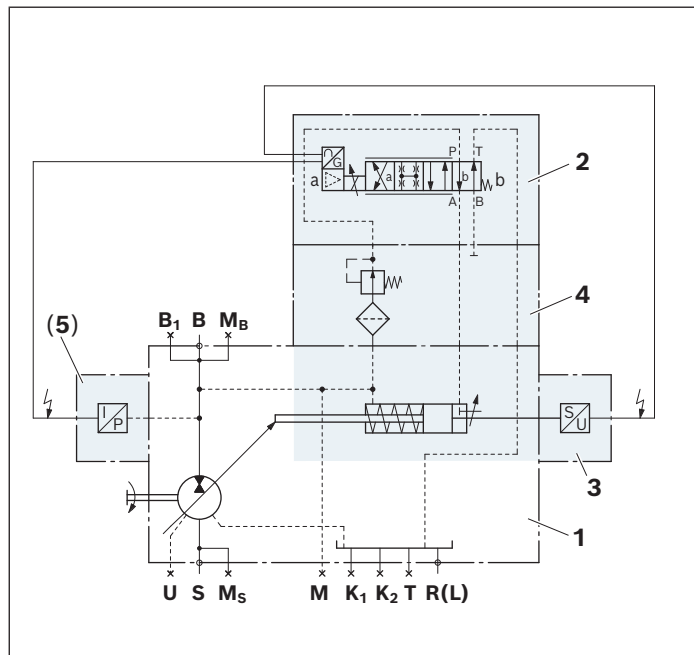

1 Pump A4VBO with hydraulic control device
(see data sheet 92122)

2 HS5E pilot control valve

NG	Type
40 to 125	HS5EN/6 CA 24L-2X/VH0/24MD7G
250	HS5EN/6 CA 40L-2X/VH0/24MD7G

3 Swivel angle sensor (see data sheet 30263):

NG	Type
40, 125	VT-SWA-LIN-1X/G15-1-C20
71	VT-SWA-LIN-1X/G15-2-C20
250	VT-SWA-LIN-1X/G15-3-C20

with round connector 4-pin M12 × 1

4 Pressure relief valve

5 **Only with HS5EVP:** Pressure transducer HM20-2X/630-C-K35
(see data sheet 30272) with intermediate flange

Dimensions HS5EVP

▼ **A4VSO, sizes 40 to 355, clockwise rotation**

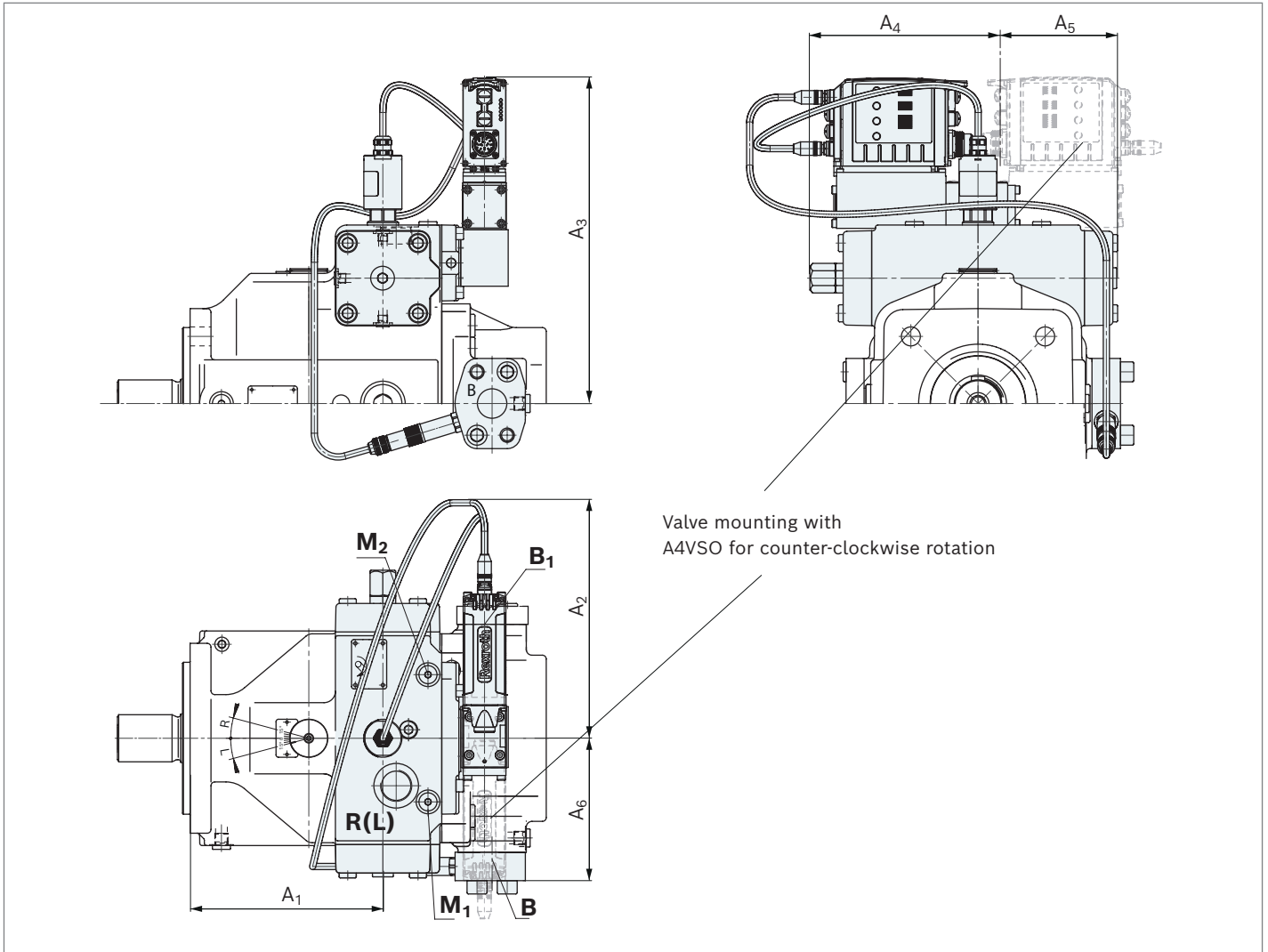

NG	A ₁	A ₂	A ₃	A ₄	A ₅	A ₆
40	144	282	293.5	130	104	120
71	166	252	309	148	126	122.5
125	203	251	343	177	147	142.5
180	203	250	343	177	147	150
250	248	248	379	213	179	174
355	248	248	379	213	179	178

For detailed dimensions and technical data of the variable pump A4VSO, see data sheet 92050

Ports	Standard	Size	p_{max} [bar] ¹⁾	State ²⁾
M ₁ , M ₂	Control pressure measuring	DIN 3852-1	M14 × 1.5; 12 deep (NG 40 to 180) M18 × 1.5; 12 deep (NG 250 and 355)	350 X

1) Depending on the application, momentary pressure peaks can occur. Keep this in mind when selecting measuring devices and fittings.

2) O = Must be connected (plugged on delivery)
X = Plugged (in normal operation)

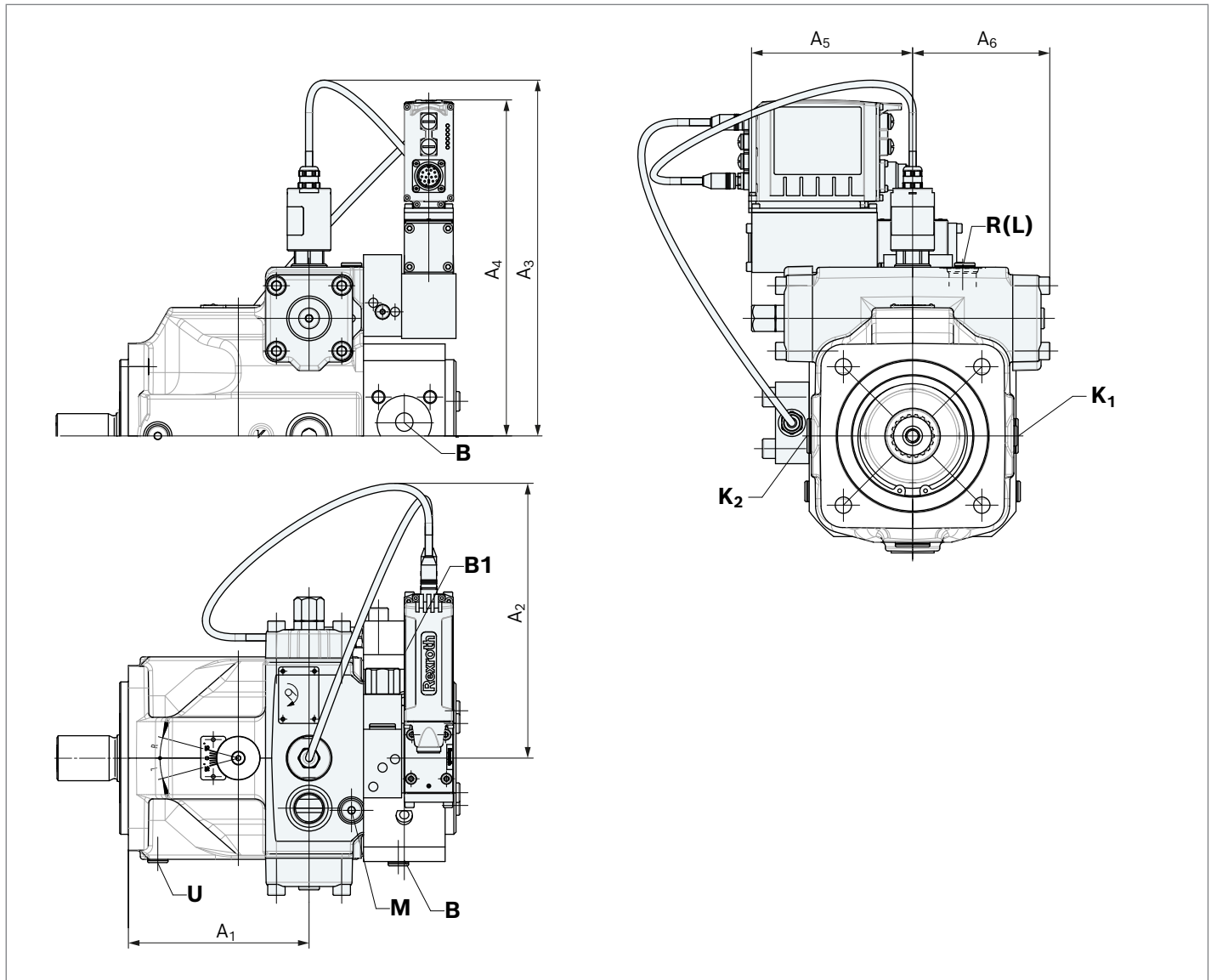
Dimensions HS5EVP▼ **A4VBO, size 71, clockwise rotation**

NG	A ₁	A ₂	A ₃	A ₄	A ₅	A ₆
71	166	approx. 252	approx. 320	309	148	126
125	On request					
250	On request					

For detailed dimensions and technical data of the variable pump, see data sheet 92122 (A4VBO)

Ports	Standard	Size	p_{\max} [bar] ¹⁾	State ²⁾
M	DIN 3852-1	M14 × 1.5; 12 deep (size 40 to 71) M18 × 1.5; 12 deep (size 125 to 355)	350	X

1) Depending on the application, momentary pressure peaks can occur. Keep this in mind when selecting measuring devices and fittings.

2) O = Must be connected (plugged on delivery)
X = Plugged (in normal operation)

HS5EL(P) – control with internal control pressure supply for A4CSG

Type	NG	250	355	500	750	
A4CSG		•	•	•	•	HS5EL(P)

The **HS5EL(P)** variant corresponds to the HS5E version but with internal control pressure supply. With a rotating pump and not active control (valve de-energized), the pump swivels to $-V_{g \max}$ by the boost pressure. The control pressure supply takes place directly from the high pressure or boost pressure. This removes the need for an external control pressure supply. With the electric motor switched off and actuator system depressurized, the pump swivels to 0 swivel angle through spring-centering.

Notes

- ▶ The spring feedback in the controller and pump control spring centering are no safety devices. The controller can stick in an undefined position due to internal contamination (contaminated hydraulic fluid, abrasion or residual contamination from system components). As a result, the flow in the axial piston unit will no longer respond correctly to the operator's specifications. Check whether the application on your machine requires additional safety measures to bring the driven consumer to a safe position (immediate stop).

For safe control, the control pressure must be twice the boost pressure (for NG 355 +5 bar). See also boost pressures in data sheet 92105.

Machine and system dynamics must be optimized by the system operator using the pressure control function.

- ▶ Optional (HS5ELP): two pressure transducers with A4CSG

To ensure the functional reliability for the HS5EL(P) control system, the operating fluid must have a min. cleanliness level of 18/16/13 as defined in ISO 4406. Further details and information on the required cleanliness level of the hydraulic fluid can be found in the operating instructions 92076-01-B.

Technical data HS5EL

Size	NG	250 to 750
Maximum working pressure $p_{\max}^{1)}$	bar	350
Minimum working pressure p_{\min}	bar	20
Minimum required control pressure	bar	Double boost pressure (+5 bar with NG 355)

Circuit diagram HS5EL

▼ Sizes 500 to 750

Example: A4CSG 500 HS5EL

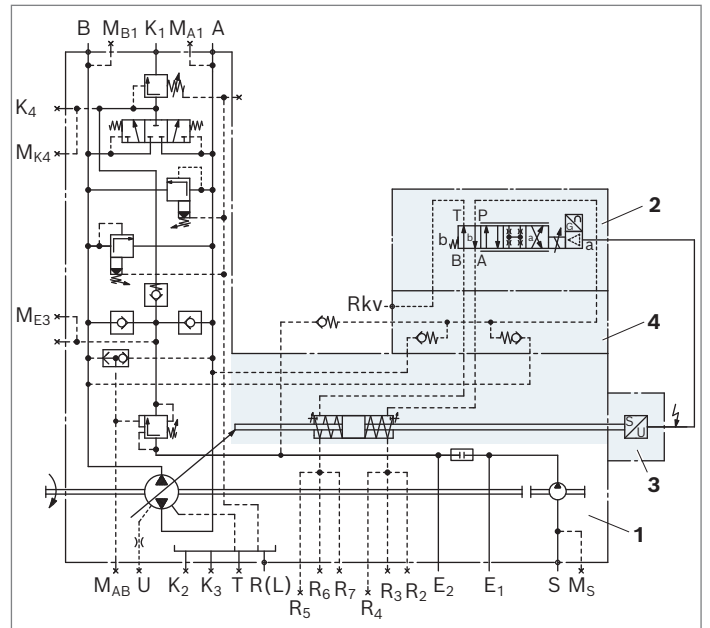

- 1 Pump with hydraulic control device A4CSG (see data sheet 92105)
- 2 HS5E pilot control valve

NG	Type
250 to 750	HS5EN/6 CA 40L-2X/VH0/24MD7G

- 3 Swivel angle sensor (see data sheet 30263):

NG	Type
250 to 750	VT-SWA-LIN-1X/G15-3-C20

with round connector 4-pin M12 × 1

- 4 Intermediate plate

▼ Flow direction in closed circuit

Direction of rotation		Swiveling range
clockwise	counter-clockwise	
B to A	A to B	clockwise
A to B	B to A	counter-clockwise

Dimensions HS5EL

▼ **A4CSG, sizes 250 to 750, clockwise rotation**

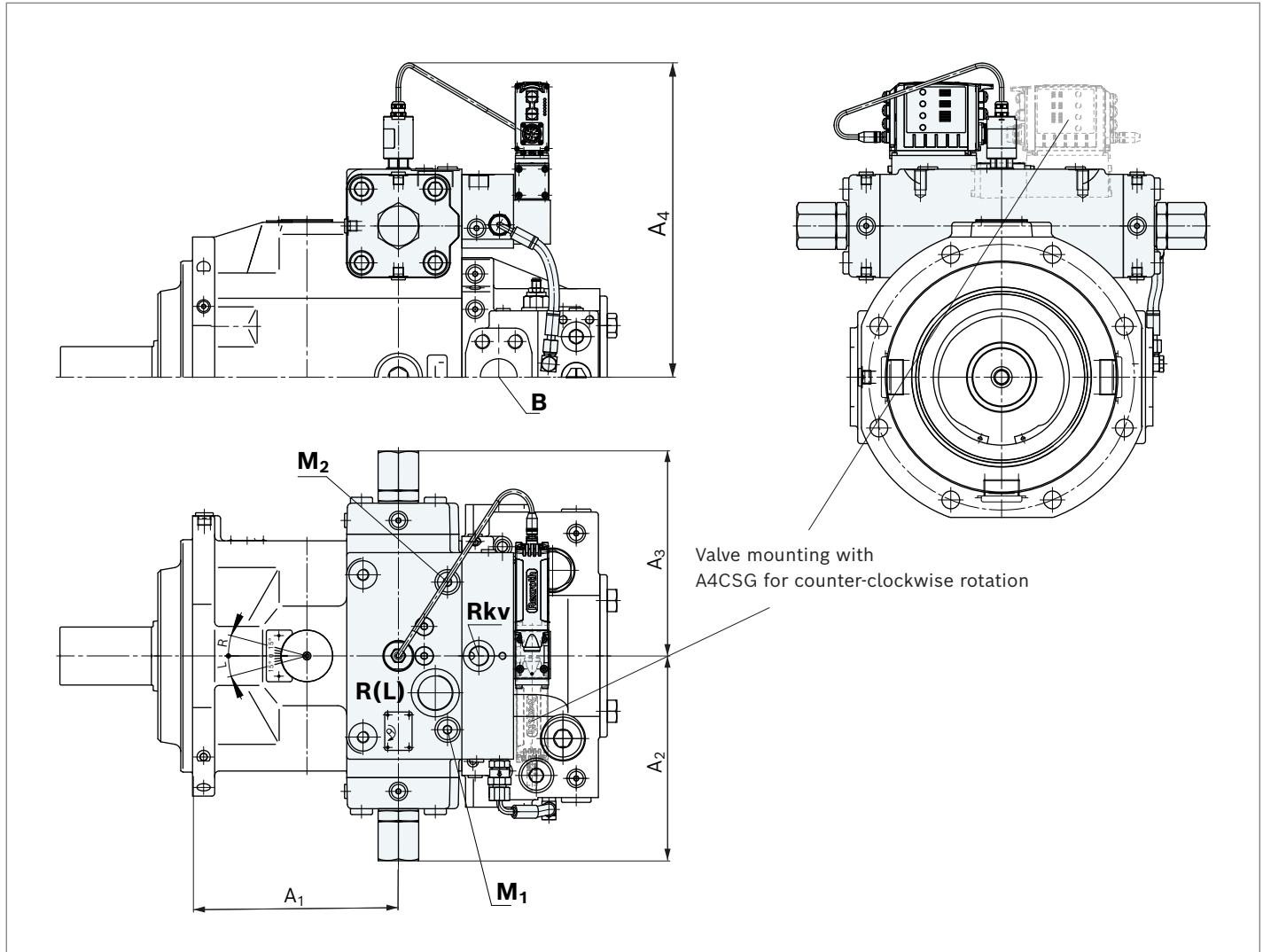

NG	A ₁	A ₂	A ₃	A ₄
250	248	242.5	242.5	approx. 390
355	248	242.5	242.5	approx. 390
500	279	278	278	approx. 448
750	279	278	278	approx. 485

For detailed dimensions and technical data of the variable pump A4CSG, see data sheet 92105

Ports	Standard	Size	p _{max} [bar] ¹⁾	State ²⁾	
M₁, M₂	Control pressure measuring	DIN 3852-1	M18 × 1.5; 12 deep (NG 250 and 355)	350	X
M_{A2}, M_P			M14 × 1.5; 12 deep (NG 500)	350	X

1) Depending on the application, momentary pressure peaks can occur. Keep this in mind when selecting measuring devices and fittings.

2) O = Must be connected (plugged on delivery)
 X = Plugged (in normal operation)

HS5(E)K / EO1K / EO2K – short circuit valve

Type	NG	40	71	125	180	250	355	500	750	1000	
A4VSG		●	●	●	●	●	●	●	●	●	HS5(E)K
A4CSG		–	–	–	–	●	●	●	●	–	
A4VSG		●	●	●	–	●	–	–	–	–	EO1K
		●	●	●	●	●	●	◇ ²⁾	◇ ²⁾	◇ ²⁾	EO2K
A4CSG		–	–	–	–	●	●	◇ ²⁾	◇ ²⁾	–	

A 4/2-way shut-off valve is installed between the proportional or control valve and the control device.

Notes

- ▶ The short circuit switching is used for setting and adjustment in depressurized neutral position, but with no defined reset during high-pressure operation
- ▶ The spring feedback in the controller and pump control spring centering are no safety devices. The controller can stick in an undefined position due to internal contamination (contaminated hydraulic fluid, abrasion or residual contamination from system components). As a result, the flow in the axial piston unit will no longer respond correctly to the operator's specifications. Check whether the application on your machine requires additional safety measures to bring the driven consumer to a safe position (immediate stop).
- ▶ With a de-energized short circuit valve, the proportional valve has no function due to the interrupted connection, i.e. the control does not follow the setpoint value.

● = **short circuit valve** (4/2-way shut-off valve)

Type Z4WE6E68-3X/EG24N9Z4/V¹⁾ (see data sheet 23193, please observe performance limits).

◇ = **short circuit valve** (4/2-way shut-off valve)

Type Z4WEH10E68-4X/6EG24N9ETZ4/B10D3¹⁾ (see data sheet 24753).

Detailed information on EO1 and EO2 control is available from page 61.

To ensure the functional reliability for the HS5(V)(L)(P) control system, the operating fluid must have a min. cleanliness level of 18/16/13 as defined in ISO 4406. Further details and information on the required cleanliness level of the hydraulic fluid can be found in the operating instructions 92076-01-B.

¹⁾ With plug-in connector according to DIN EN 175301-803 / ISO 4400
 Cable gland M16 × 1.5 for cable diameters 4.5 to 10 mm

²⁾ For circuit diagram and dimensions, see page 57

Circuit diagrams

▼ **Sizes 125 to 355**

Example: open circuit A4VSO **EO2K**

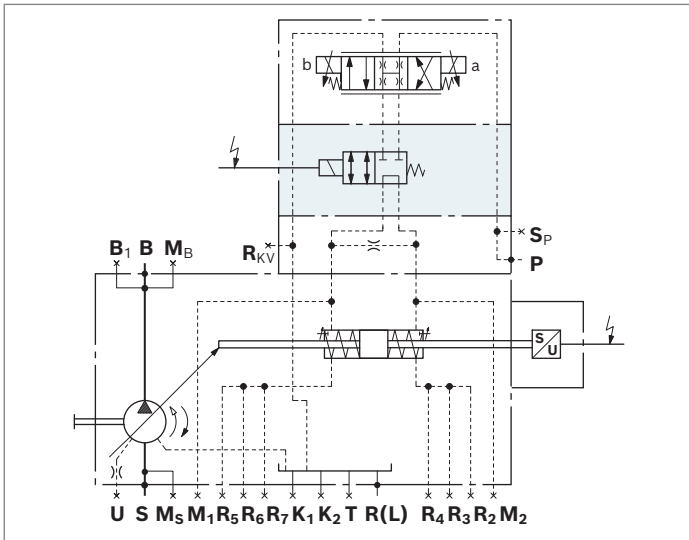

▼ **Sizes 500 to 1000**

Example: closed circuit A4VSG **HS5KP**

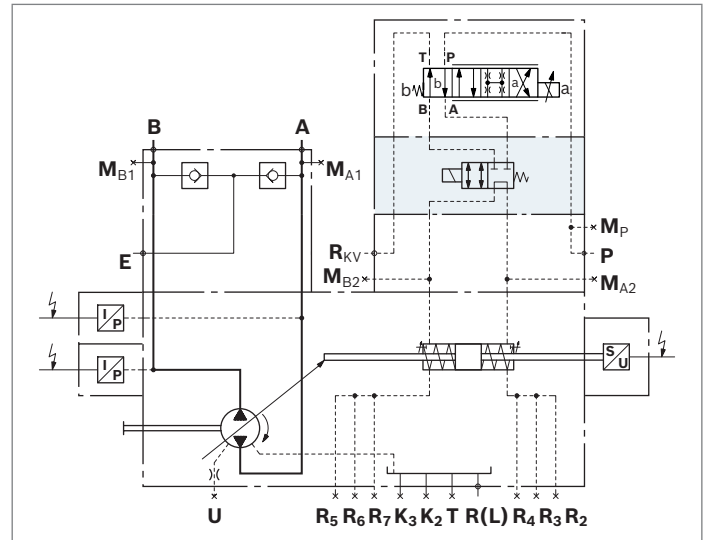

▼ **Sizes 40 to 355**

Example: closed circuit A4VSG 125**HS5EKP**

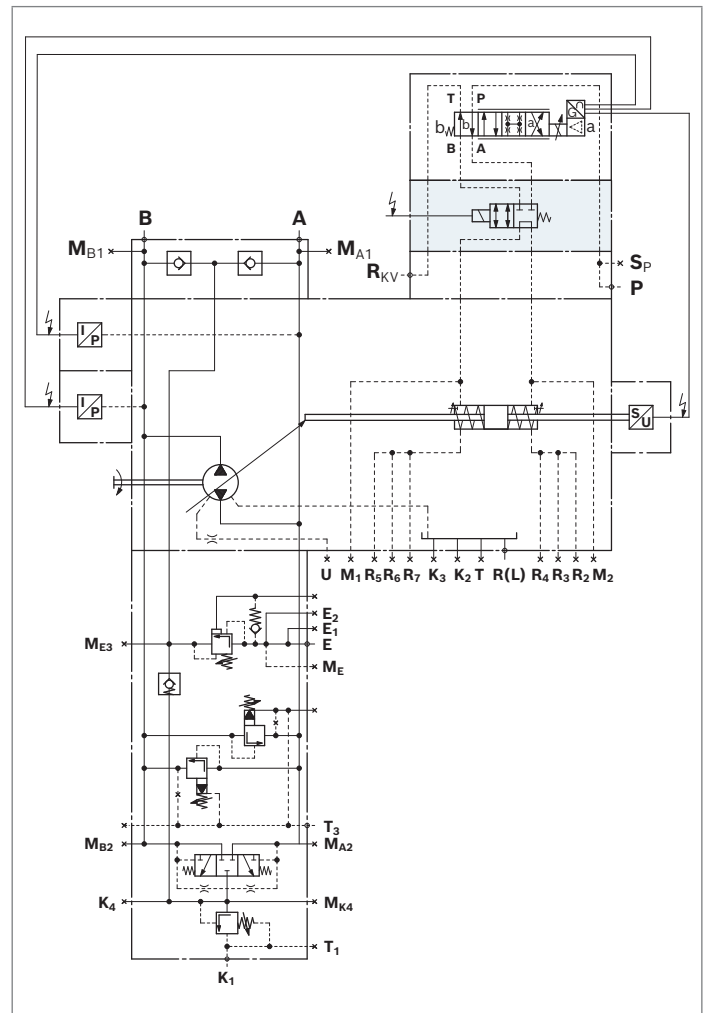

Dimensions

▼ **HS5K, size 40 to 355**

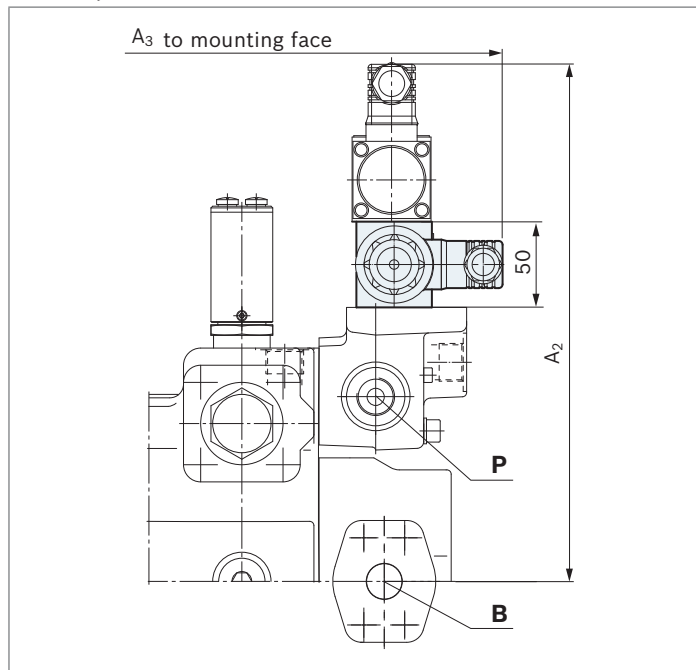

▼ **HS5K, sizes 500 to 1000**

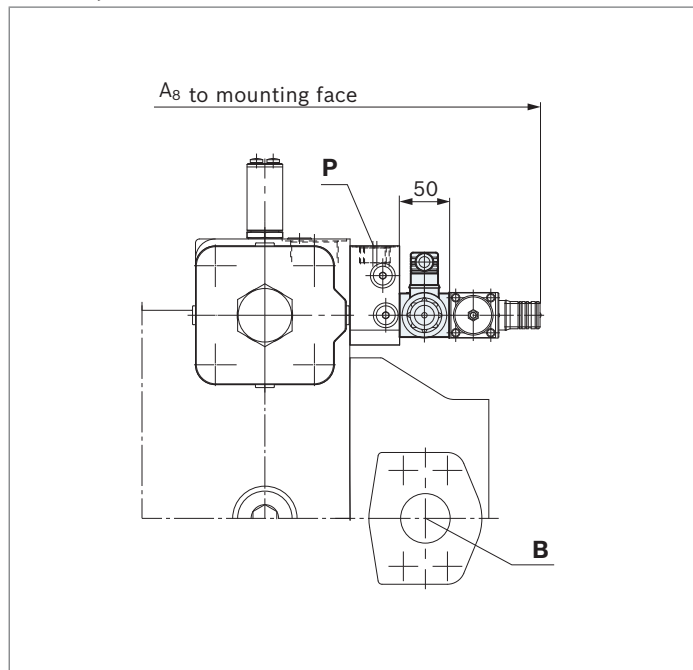

▼ **EO1K, size 40 and 71**

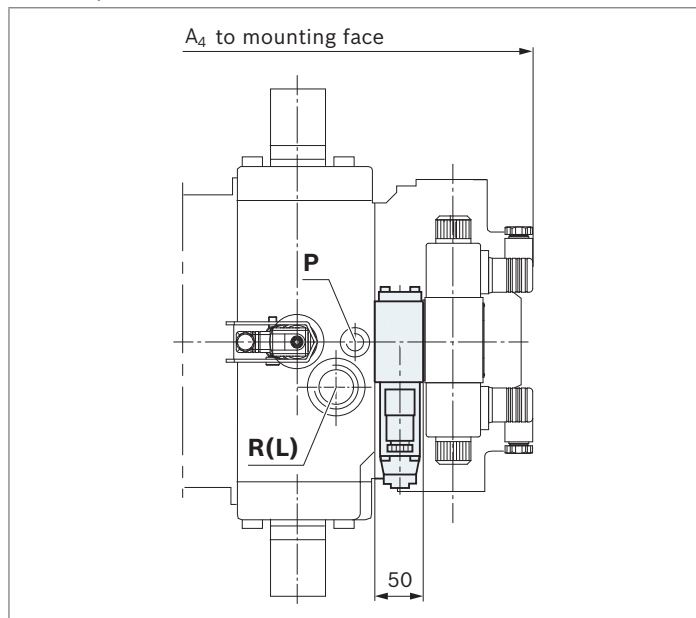

▼ **EO1K, sizes 125 and 250**
EO2K, size 40 to 355

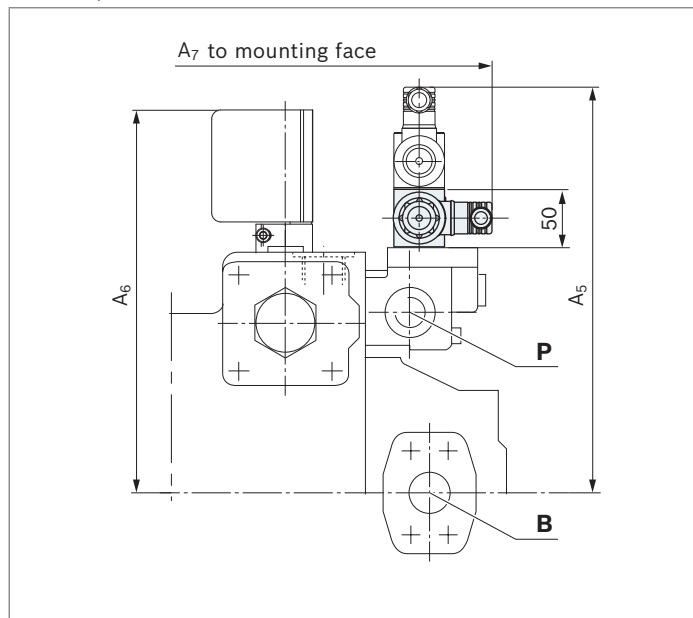

NG	A ₂	A ₃	A ₄	A ₅	A ₆	A ₇	A ₈
40	301	296	324	298	246	295	–
71	311	323	351	314	265	322	–
125 / 180	336	381	–	331	298	379	–
250 / 355	365.5	443	–	365	345	443	–
500	–	–	–	–	–	–	551
750	–	–	–	–	–	–	583
1000	–	–	–	–	–	–	649

Dimensions A4VSG

▼ **HS5EK, sizes 40 to 355**

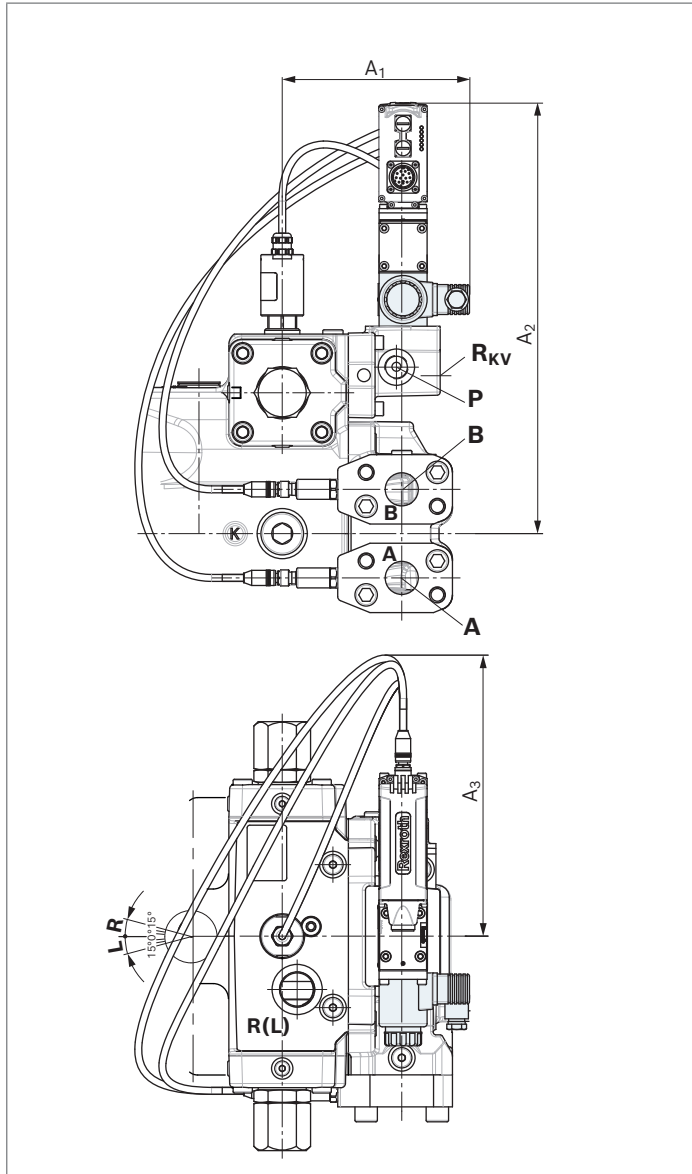

▼ **HS5EK, sizes 500 to 1000**

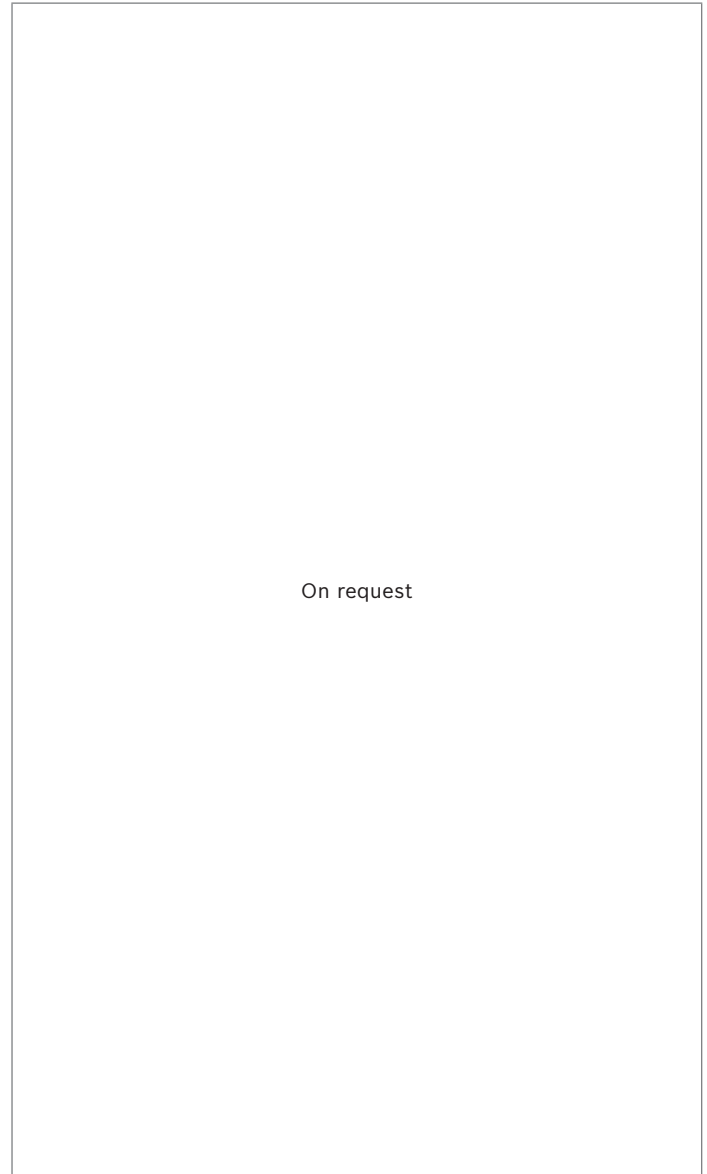

NG	A ₁	A ₂	A ₃
40		On request	
71		On request	
125 / 180	175.5	403.4	approx. 263
250 / 355			
500		On request	
750		On request	
1000		On request	

Circuit diagram EO2K

▼ **Sizes 500 to 1000**

Example: closed circuit A4VSG **EO2K**

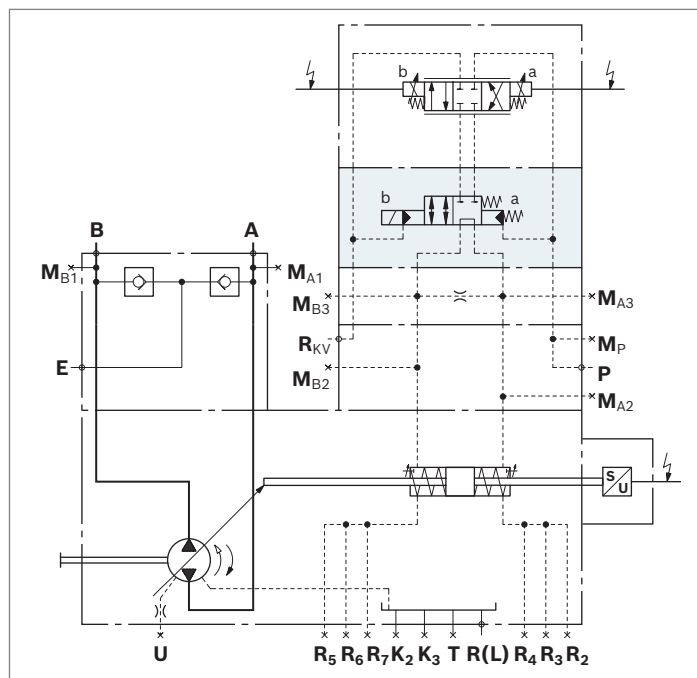

Dimensions EO2K

▼ **Sizes 500 to 1000**

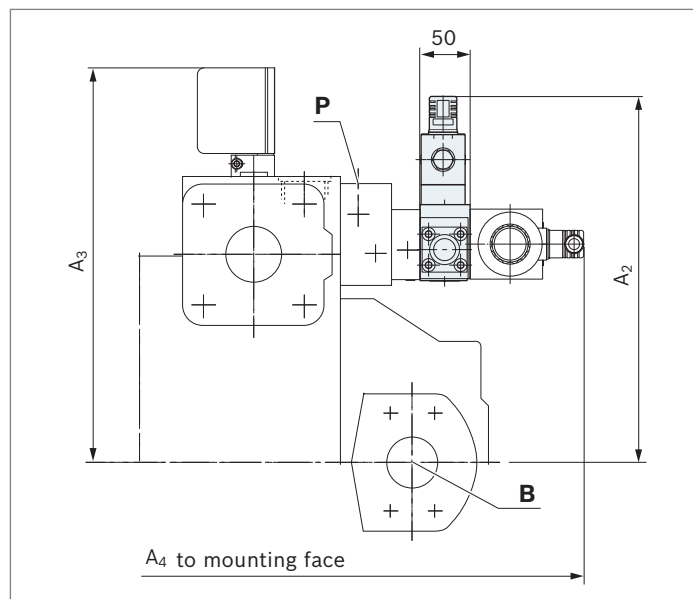

NG	A ₂	A ₃	A ₄
500	386	392	609
750	417	427	641
1000	439	456	707

HS5(E)Z(P) – Zero swivel function with (de-energized) control valve for A4VSG and A4CSG

Type	NG	40	71	125	180	250	355	500	750	1000	
A4VSG		-	-	-	-	-	-	●	○	○	HS5(E)Z(P)
A4CSG		-	-	-	-	-	-	●	○	-	

If the activation valve (4) is de-energized, the zero swivel function starts when the control pressure is applied. As a result, the HS5(E) control valve (2) is switched inoperative, and at the same time the swivel angle control of the zero swivel function takes over. In the closed circuit, the HS5(E) control system swivels to swivel angle $\alpha = -100\%$ due to its design. The control position of the zero swivel function, on the other hand, is in the central position at 0% swivel angle.

Notes

- ▶ The pump control zero swivel function is not a safety device. The controller can stick in an undefined position due to internal contamination (contaminated hydraulic fluid, abrasion or residual contamination from system components). As a result, the flow in the axial piston unit will no longer respond correctly to the operator's specifications. Check whether the application on your machine requires additional safety measures to bring the driven consumer to a safe position (immediate stop).

Technical data hydraulic HS5(E)Z

Size	500		
Control pressure at port P			
Minimum	p_{min}	bar	150
Maximum	p_{max}	bar	350
Control fluid return flow $R_{KV}^{1)}$	p_{max}	bar	<4
Minimum required control fluid supply	q_{Vmin}	l/min	50

Technical data electric HS5(E)Z

Size	500	
Electric switching signal for the activation of the zero swivel function	V	24

▼ Characteristic curve of control fluid supply at port P

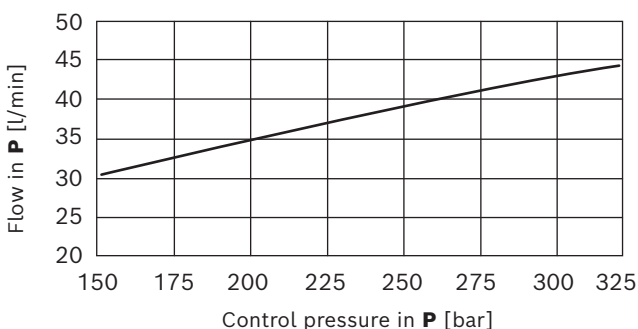

Actuating times zero swivel

The maximum swivel time is <1 second.

The actuating time of the zero swivel function depends on the operating point and applies under the following boundary conditions:

- ▶ Compliance with control pressure specifications.
- ▶ To ensure the actuating time, an optimum temperature range with an operating viscosity of ν_{opt} 16...36 mm²/s is required (see data sheet 92100 and 92105).

Accuracy zero swivel

Achievable accuracy of the neutral position: 0% +/- 2% referred to 100% of the swivel angle signal Boundary conditions:

- ▶ To ensure accuracy, an optimum temperature range with an operating viscosity of ν_{opt} 16...36 mm²/s is required (see data sheet 92100 and 92105).
- ▶ The required control pressure is at least 150 bar.

The applied control pressure has a direct influence on the accuracy of the zero swivel function.

Therefore, it is recommended to specify the control pressure available in the system when ordering.

When determining the control pressure at port **P** of the unit, the relationship from the "Control fluid supply at port **P**" characteristic curve must be taken into account.

The value refers to the calibrated swivel angle zero point during the final inspection on the test rig.

Attention

- ▶ Through the calibration function of the swivel angle zero point, it is not guaranteed in a closed loop pump, that the pressure in **A** and **B** will be equal at 0% swivel angle. If this is desired, the swivel angle zero point has to be readjusted manually on the pump itself.
- ▶ The zero swivel function only applies to the operation as a pump with load-free neutral position.

1) The R_{KV} port must be unloaded to the reservoir.

Circuit diagram HS5Z

▼ **Example A4CSG size 500**

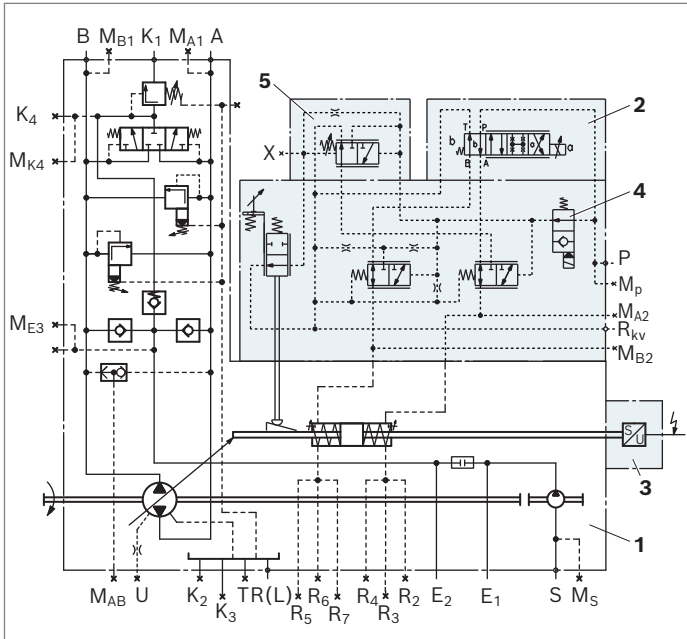

- 1 Pump with hydraulic control device A4CSG (see data sheet 92105)
- 2 4/4 directional control valve (see data sheet 29027)

NG	Type
500	4WRPH6CA40L-2X/G24Z4/V-855

- 3 Inductive position transducer:

NG	Type
500	AWAX004D02

with round connector 4-pin M12 × 1

- 4 Valve (drawn de-energized) for the activation of the zero swivel function
- 5 DRG control valve

▼ **Flow direction in closed circuit**

Direction of rotation		Swiveling range
clockwise	counter-clockwise	
B to A	A to B	clockwise
A to B	B to A	counter-clockwise

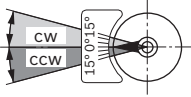

Circuit diagram HS5EZ

▼ **Example A4CSG size 500**

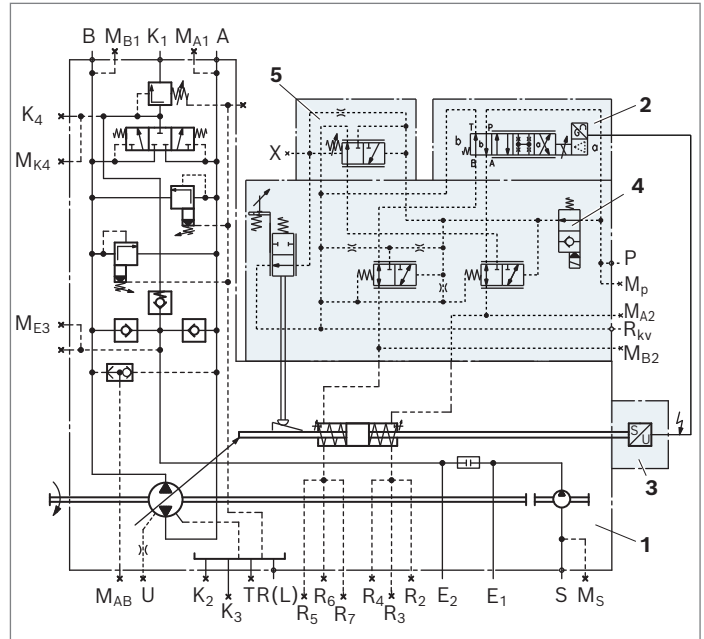

- 1 Pump with hydraulic control device A4CSG (see data sheet 92105)
- 2 HS5E pilot control valve

NG	Type
500	HS5EN/6 CA 40L-2X/VH0/24MD7G

- 3 Swivel angle sensor (see data sheet 30263):

NG	Type
500	VT-SWA-LIN-1X/G15-3-C20

with round connector 4-pin M12 × 1

- 4 Valve (drawn de-energized) for the activation of the zero swivel function
- 5 DRG control valve

▼ **Flow direction in closed circuit**

Direction of rotation		Swiveling range
clockwise	counter-clockwise	
B to A	A to B	clockwise
A to B	B to A	counter-clockwise

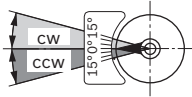

Dimensions HS5Z and HS5EZ

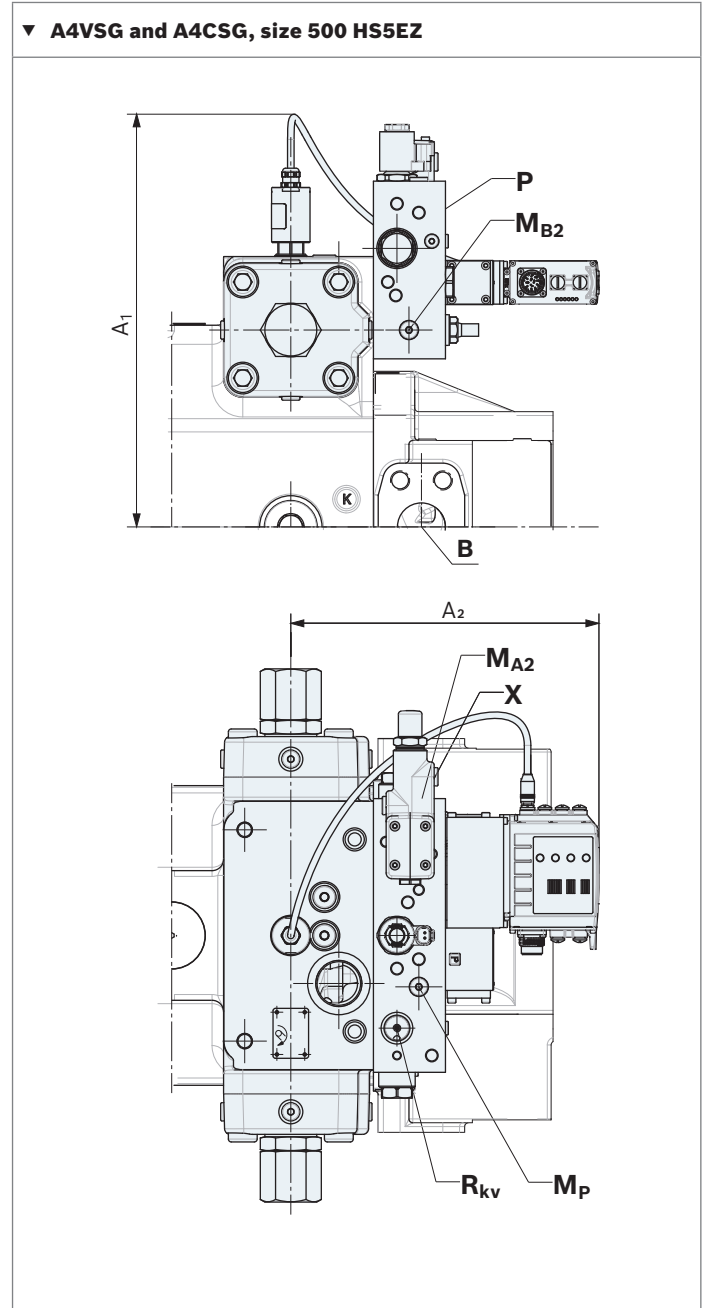
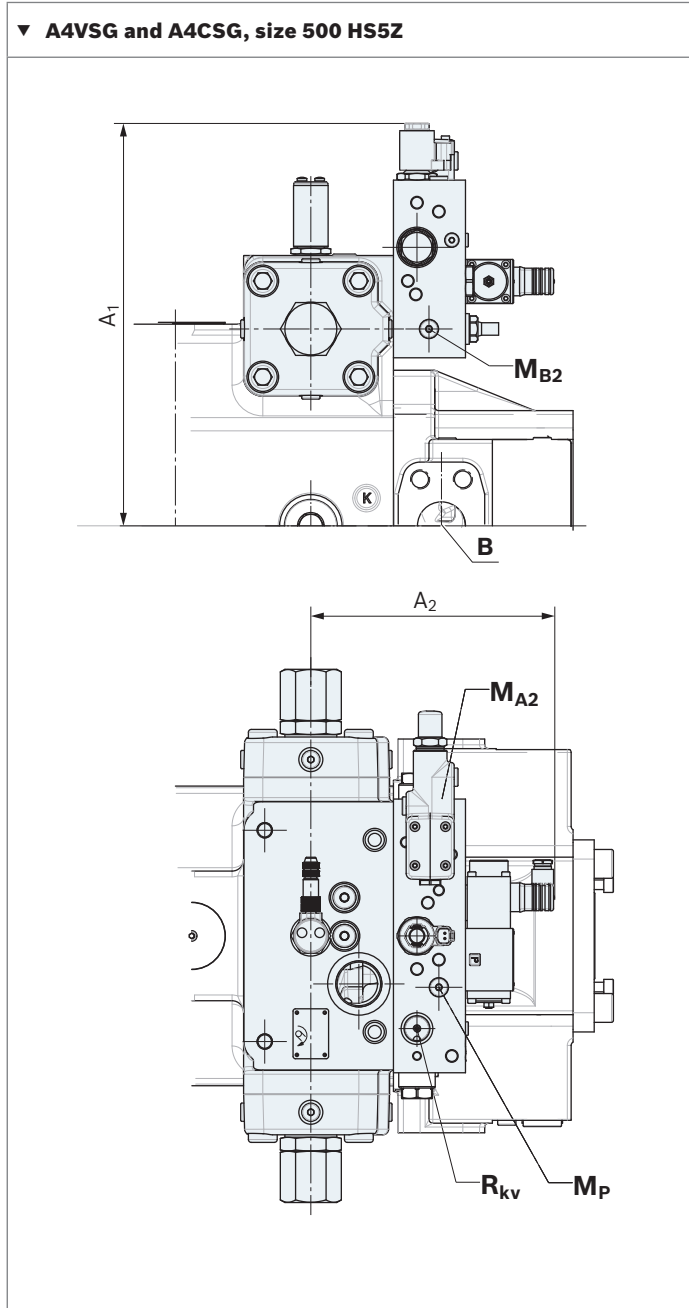

NG	A ₁	A ₂	
500 (HS5Z)	419	253	
500 (HS5EZ)	approx. 448	321	

For detailed dimensions and technical data for the variable pump, see data sheet 92050 (A4VSO) or 92100 (A4VSG)

Ports	Standard	Size	p_{max} [bar] ¹⁾	State ²⁾	
P	Control pressure	DIN 3852-1	M27 × 2; 16 deep	350	O
MA₂, MB₂, MP	Control pressure measuring port	DIN 3852-1	M14 × 1.5; 12 deep	350	X
R_{KV}	Control fluid return flow	DIN 3852-1	M27 × 2; 16 deep	4	O
X	Pilot pressure port	DIN 3852-1	M14 × 1.5; 12 deep	350	X

1) Depending on the application, momentary pressure peaks can occur. Keep this in mind when selecting measuring devices and fittings.

2) O = Must be connected (plugged on delivery)
 X = Plugged (in normal operation)

EO1 / EO2 – control with proportional valve

Type	NG	40	71	125	180	250	355	500	750	1000	
A4VSO, A4VSG		●	●	●	–	●	–	–	–	–	EO1
		●	●	●	●	●	●	●	●	●	EO2
A4CSG		–	–	–	–	●	●	●	●	–	

For electric displacement control with VT-5035-1X

The control **EO1/2** sets the displacement of the pump with the mounted direct operated proportional directional valve proportional to the setpoint value.

The pump setting is reported by an inductive position transducer.

Spring-centering

The spring-centering of the hydraulic stroking cylinder is standard. It is used for setting and adjustment in the depressurized neutral position, but without a defined reset during high-pressure operation.

Notes

- ▶ The spring feedback in the controller and pump control spring centering are no safety devices. The controller can stick in an undefined position due to internal contamination (contaminated hydraulic fluid, abrasion or residual contamination from system components). As a result, the flow in the axial piston unit will no longer respond correctly to the operator's specifications. Check whether the application on your machine requires additional safety measures to bring the driven consumer to a safe position (immediate stop).

Swivel angle limitation

Minimum and maximum swivel angle limitation

is mechanically adjustable up to 50 % $V_{g \max}$.

For size 500, $V_{g \min}$ is adjustable up to 50 % $V_{g \max}$ and $V_{g \max}$ up to 70 % $V_{g \max}$.

Notes

Setting with A4VSO (open circuit):

- ▶ The $V_{g \max}$ stop is set to nominal $V_{g \max}$ as standard. Please specify different values in your order
- ▶ The $V_{g \min}$ stop is set to $V_g = 0$ l/min with $P_{HD} = 20$ bar as standard. Other values should be specified when placing the order.

Setting with A4VSG and A4CSG (closed circuit):

- ▶ The $V_{g \max}$ stops are set on both sides to nominal $V_{g \max}$.

When ordering, please state other setting requests in plain text.

Electric amplifier

The electric amplifier VT 5035-1X for controlling the pump swivel angle is not included in the EO scope of delivery, please order separately in accordance with data sheet 29955.

Two versions are available:

Type	Control pressure [bar]	Sizes
EO1	from 20	40, 71, 125 and 250 (see from page 62)
EO2	from 50/100/125	40...1000 (see from page 64)

A4VSO – open circuit

▼ Characteristic curve

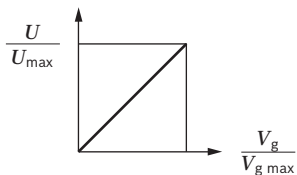

▼ Flow direction S to B

Direction of rotation	Swiveling range ¹⁾	Actuation of solenoid
clockwise	counter-clockwise	a
counter-clockwise	clockwise	b

Overcenter is available on request.

A4VSG and A4CSG – closed circuit

▼ Characteristic curve

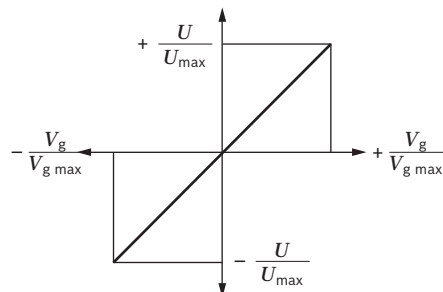

▼ Flow direction

Direction of rotation	Swiveling range ¹⁾	Flow direction	Actuation of solenoid
clockwise	clockwise	B to A	b
	counter-clockwise	A to B	a
counter-clockwise	clockwise	A to B	b
	counter-clockwise	B to A	a

Technical data EO1

Size		NG	40	71	125	250
Control pressure (in P)	p_{min}	bar	20	20	20	20
	p_{max}	bar	100	100	100	100
Control stroke	s_{max}	mm	14.2	17.1	20.7	25.9
Control area	A	cm ²	16.6	24.6	36.6	56.7
Control volume	$V_{S max}$	cm ³	23.6	42.1	75.2	147
Setting time ²⁾	t_{min}	s	0.12	0.20	0.22	0.40
Weight: approx. (A4VSO...EO1...N00)	m	kg	42	59	98	200
Maximum hysteresis ΔV_g ³⁾			$\leq \pm 2\%$ of $V_{g max}$			
Minimum repeatability ³⁾			$\leq \pm 1.5\%$ of $V_{g max}$			
Linearity deviation ³⁾			$\leq 2.5\%$ of $V_{g max}$			

1) Cf. Swivel angle indicator

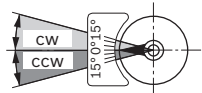

2) With 50 bar control pressure

3) Values are valid for a constant operating temperature of 50 °C

Circuit diagrams EO1

The control fluid to be supplied externally on port **P** is drained internally via the drain port **R(L)** of the pump.

▼ Sizes 40 and 71

Example: closed circuit A4VSG

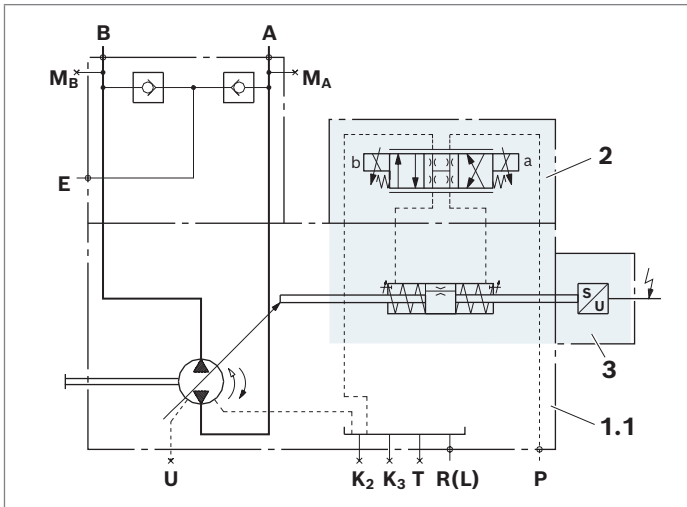

▼ Sizes 125 to 355

Example: open circuit A4VSO

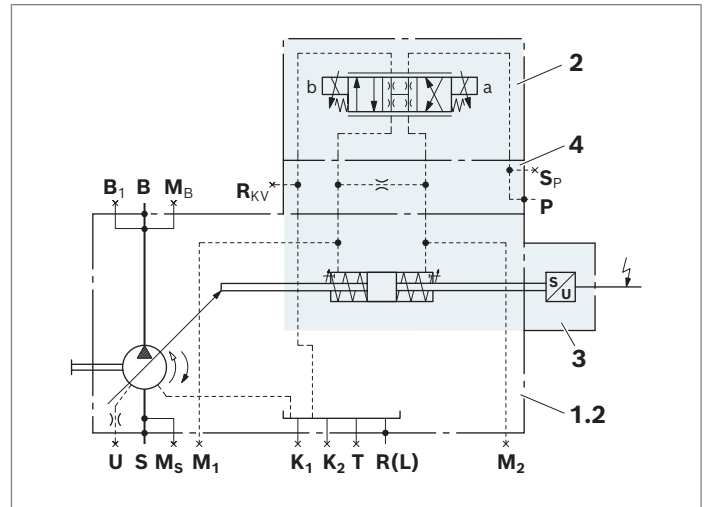

- 1 Pump with hydraulic control device
 - 1.1 A4VSG (see data sheet 92100)
 - 1.2 A4VSO (see data sheet 92050)
 - 2 4/3-way proportional valve (see data sheet 29055)
- | NG | Type ¹⁾ |
|-------------|---------------------------|
| 40 and 71 | 4WRA6V15-2X/G24N9K4/V-589 |
| 125 and 250 | 4WRA6V30-2X/G24N9K4/V-589 |
- 3 Inductive position transducer AWXX004D02¹⁾
 - 4 Flow control plate

Ports	
P	Control pressure
S_P	Control pressure accumulator
R_{KV}	Control fluid return flow
M₁, M₂	Measuring ports control pressure

1) Solenoids with plug-in connector according to DIN EN 175.301-803 / ISO 4400
 Cable gland M16 × 1.5 for cable diameters 4.5 to 10 mm

Dimensions EO1

▼ **A4VSO and A4VSG, size 40 and 71**

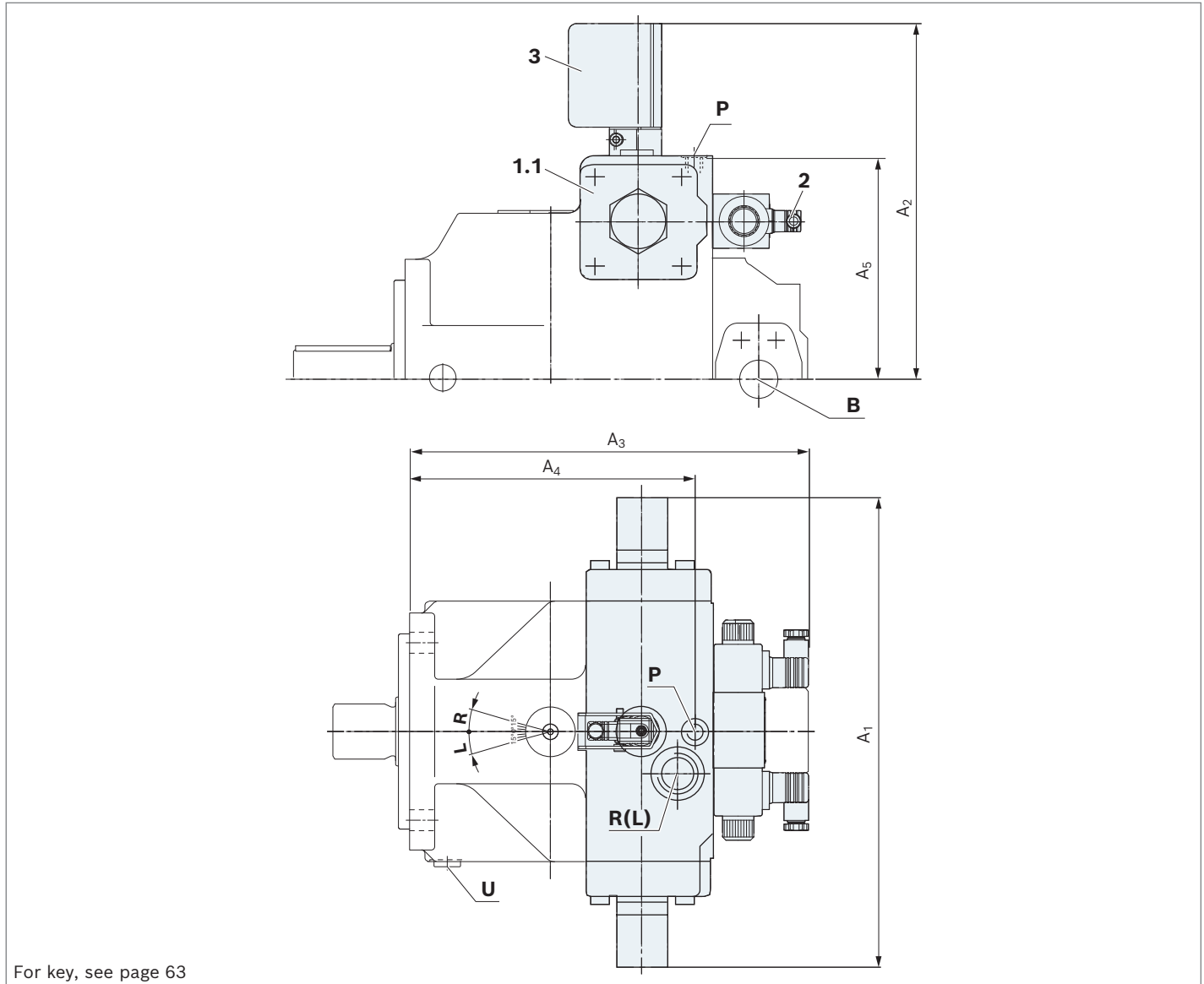

For key, see page 63

NG	A ₁	A ₂	A ₃	A ₄	A ₅	
40	296	246	279	178	135	For detailed dimensions and technical data for the variable pump, see data sheet 92050 (A4VSO) or 92100 (A4VSG)
71	332	265	306	205	152	

Ports	Standard	Size ¹⁾	p _{max} [bar] ²⁾	State
P	DIN 3852-1	M14 × 1.5; 12 deep	100	O

1) Depending on the application, momentary pressure peaks can occur. Keep this in mind when selecting measuring devices and fittings.

2) O = Must be connected (plugged on delivery)
X = Plugged (in normal operation)

▼ **A4VSO and A4VSG, size 125 and 250**

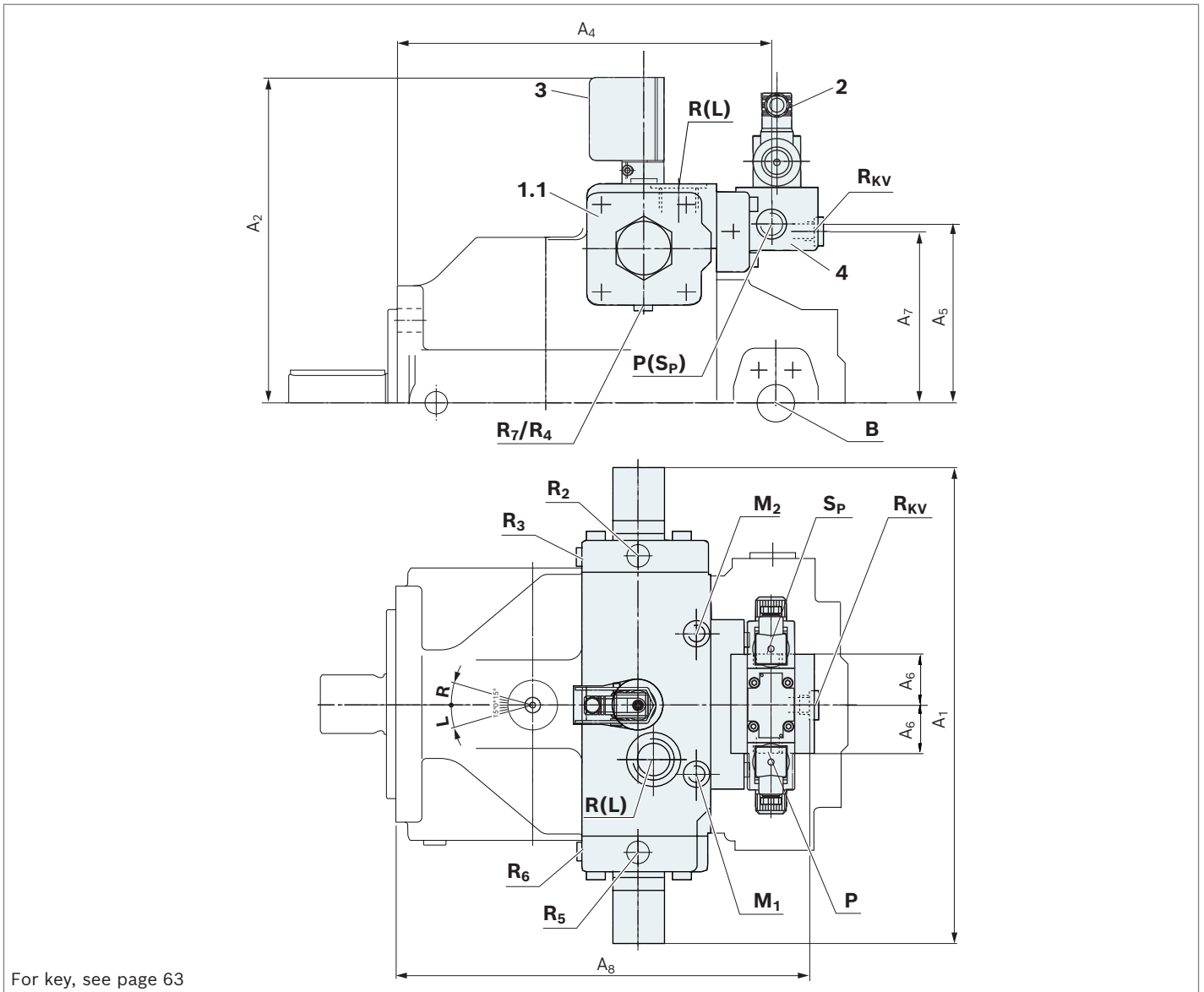

NG	A ₁	A ₂	A ₄	A ₅	A ₆	A ₇	A ₈	
125	402	298	312	156	39	148	352	For detailed dimensions and technical data for the variable pump, see data sheet 92050 (A4VSO) or 92100 (A4VSG)
250	485	345	372	192	39	184	412	

Ports		Standard	Size	p _{max} [bar] ¹⁾	State ²⁾
P	Control pressure	DIN 3852-1	M22 × 1.5; 14 deep	100	O
S _p	Control pressure accumulator	DIN 3852-1	M22 × 1.5; 14 deep	100	X
R _{kv}	Control fluid return flow	DIN 3852-1	M22 × 1.5; 14 deep	4	O
M ₁ , M ₂	Control pressure measuring	DIN 3852-1	M14 × 1.5; 12 deep (NG 125) M18 × 1.5; 12 deep (NG 250)	100 100	X X
R ₂ ... R ₇	Air bleeding the stroking chamber	DIN 3852-1	M10 × 1; 8 deep	100	X

1) Depending on the application, momentary pressure peaks can occur. Keep this in mind when selecting measuring devices and fittings.

2) O= Must be connected (plugged on delivery)
 X = Plugged (in normal operation)

Technical data EO2

Size		NG	40	71	125	180	250	355	500	750	1000
Control pressure (in P)	p_{\min}	bar	50	50	50	100	100	100	125	125	125
	$p_{\max}^{1)}$	bar	315	315	315	315	315	315	315	315	315
Control stroke	s_{\max}	mm	14.2	17.1	20.7	20.7	25.9	25.9	32.6	37.0	41.4
Control area	A	cm ²	8.1	12.6	18.1	18.1	28.3	28.3	38.2	56.8	63.6
Control volume	$V_{S \max}$	cm ³	11.4	21.5	37.5	37.5	73.2	73.2	124.5	210	263.3
Setting time ²⁾	t_{\min}	s	0.1	0.12	0.2	0.2	0.25	0.25	0.3	³⁾	³⁾
Weight: approx. (A4VSO...EO2...N00)	m	kg	42	59	98	122	200	220	338	481	611
Maximum hysteresis $\Delta V_g^{4)}$											$\leq \pm 2\%$ of $V_{g \max}$
Minimum repeatability ⁴⁾											$\leq \pm 1.5\%$ of $V_{g \max}$
Linearity deviation ⁴⁾											$\leq 2.5\%$ of $V_{g \max}$

1) Due to the permissible data of the proportional valve
 2) With minimum control pressure
 3) Values are valid for a constant operating temperature of 50 °C
 4) On request

Circuit diagrams EO2 – size 40 to 355

The control fluid to be supplied externally on port **P** is drained internally via the drain port **R(L)** of the pump. For A4CSG with EO2, the control pressure relief valve is not required and is replaced with a threaded plug. To minimize the control fluid consumption, the stroking chambers are sealed in sizes 125...355 and can be bled via the ports **R₂** to **R₇**.

▼ **Sizes 40 and 71**

Example: open circuit A4VSO

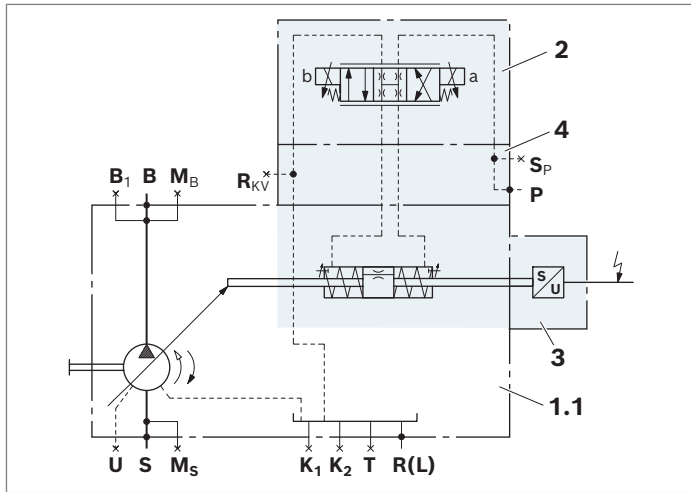

▼ **Sizes 125 to 355**

Example: open circuit A4VSO

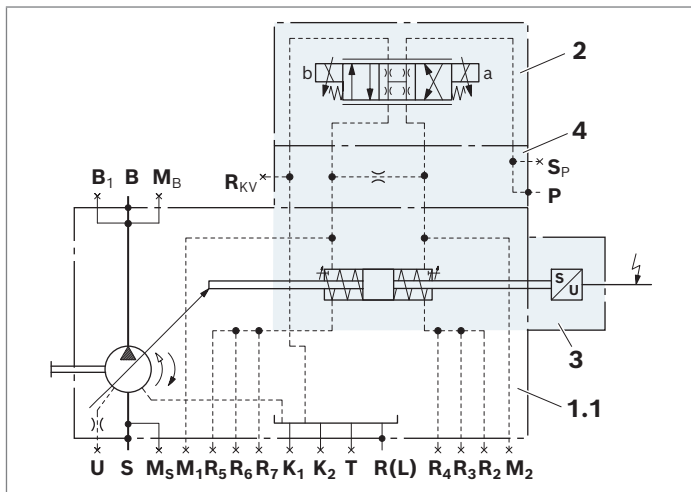

Circuit diagram EO2 – size 500 to 1000

The control fluid to be supplied externally on port **P** is drained via the port **R_{KV}** to be connected externally to the reservoir.

For A4CSG with EO2, the control pressure relief valve is not required and is replaced with a threaded plug. To minimize the control fluid consumption, the stroking chambers are sealed and can be bled via the ports **R₂** to **R₇**.

▼ **Sizes 500 to 1000**

Example: closed circuit A4VSG

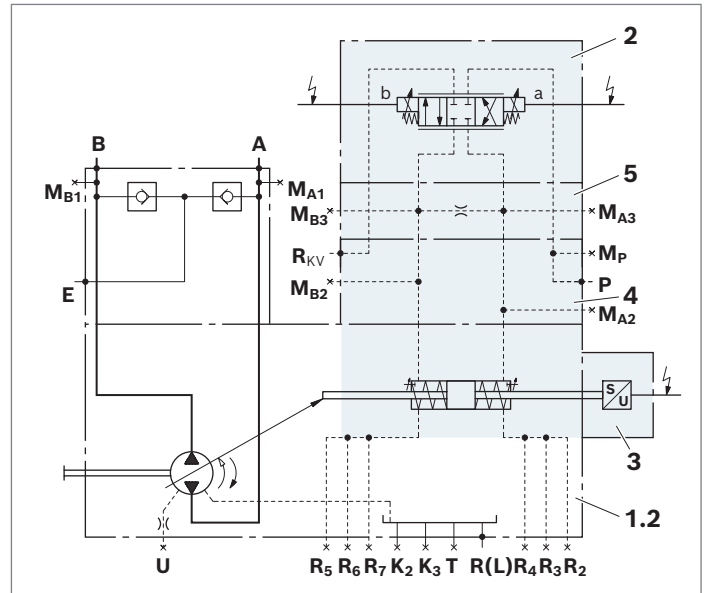

- 1 Pump with hydraulic control device
- 1.1 A4VSO (see data sheet 92050)
- 1.2 A4VSG (see data sheet 92100)
- 2 4/3-way proportional valve (see data sheet 29055 or 29061)

NG	Type ¹⁾
40 and 71	4WRA6V15-2X/G24N9K4/V-589
125 to 355	4WRA6V30-2X/G24N9K4/V-589
500 to 1000	4WRE10E25-2X/24K4/V-93

- 3 Inductive position transducer AWXX004D02¹⁾
- 4 Intermediate plate
- 5 Flow control plate

1) Solenoids with plug-in connector according to DIN EN 175.301-803 / ISO 4400 Cable gland M16 × 1.5 for cable diameters 4.5 to 10 mm

Dimensions EO2

▼ **A4VSO, A4VSG and A4CSG, size 40 to 355**

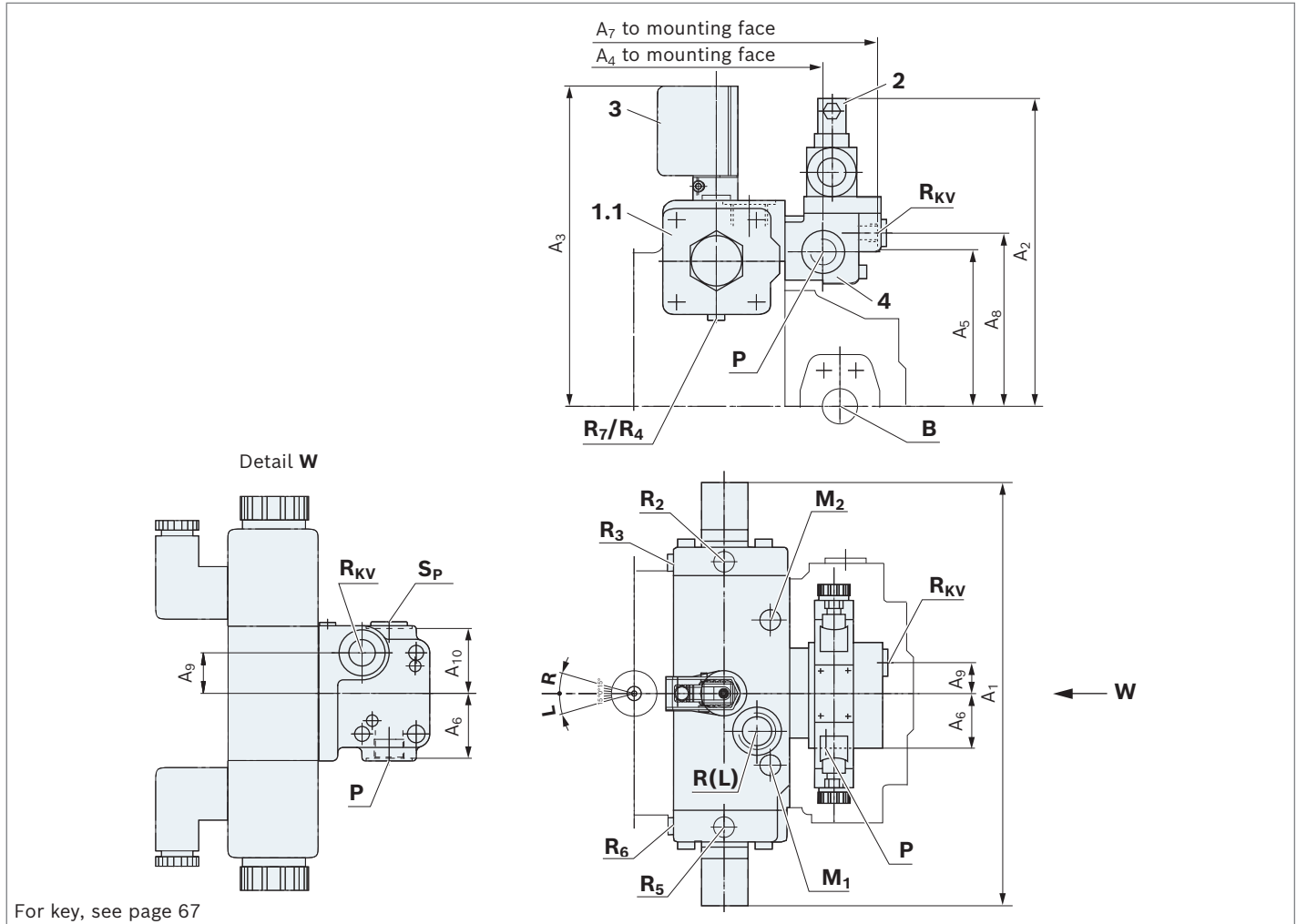

NG	A ₁	A ₂	A ₃	A ₄	A ₅	A ₆	A ₇	A ₈	A ₉	A ₁₀	
40	296	248	246	222	108	43	273	128	35	53	For detailed dimensions and technical data for the variable pump, see data sheet 92050 (A4VSO), 92100 (A4VSG) or 92105 (A4CSG)
71	332	264	265	249	123	48	300	143	30	48	
125/180	402	281	298	310	156	39	350	148	0	39	
250/355	485	317	345	372	192	39	412	184	0	39	

Ports	Standard	Size	p _{max} [bar] ¹⁾	State ²⁾
P	Control pressure	DIN 3852-1 M22 × 1.5; 14 deep	315	O
S_P	Control pressure accumulator	DIN 3852-1 M22 × 1.5; 14 deep	315	X
R_{KV}	Control fluid return flow	DIN 3852-1 M22 × 1.5; 14 deep	4	X
M₁, M₂	Control pressure measuring	DIN 3852-1 M14 × 1.5; 12 deep (NG 125 and 180) M18 × 1.5; 12 deep (NG 250 and 355)	315 315	X X
R₂ ... R₇	Air bleeding the stroking chamber	DIN 3852-1 M10 × 1; 8 deep (NG 125 to 355)	315	X

1) Depending on the application, momentary pressure peaks can occur. Keep this in mind when selecting measuring devices and fittings.

2) O = Must be connected (plugged on delivery)
X = Plugged (in normal operation)

▼ **A4VSO, A4VSG and A4CSG, sizes 500 to 1000**

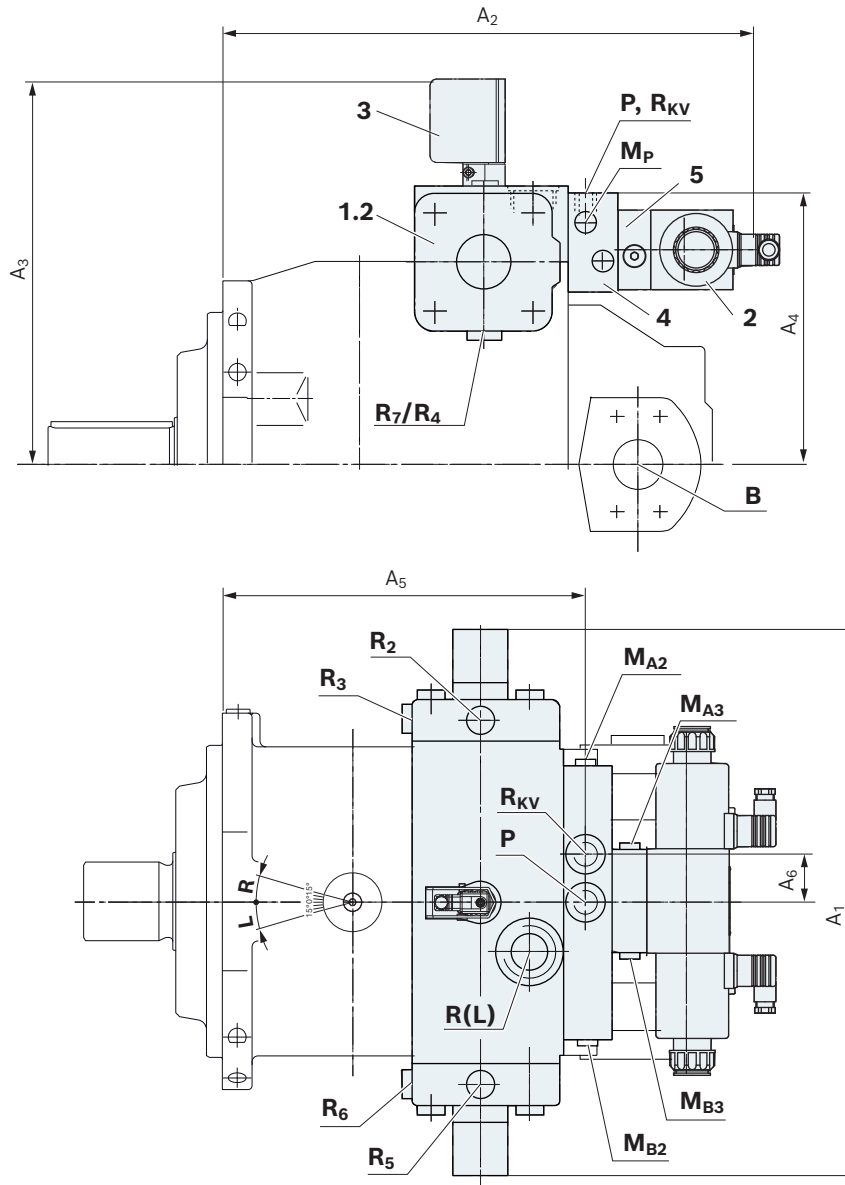

For key, see page 67

NG	A ₁	A ₂	A ₃	A ₄	A ₅	A ₆
500	555	559	392	274	388	50
750	630	591	427	304	420	50
1000	670	657	456	327	486	50

For detailed dimensions and technical data for the variable pump, see data sheet 92050 (A4VSO), 92100 (A4VSG) or 92105 (A4CSG)

Ports	Standard	Size ¹⁾	p _{max} [bar] ²⁾	State
P	Control pressure	DIN 3852-1 M27 × 2; 16 deep	315	O
R_{KV}	Control fluid return flow	DIN 3852-1 M27 × 2; 16 deep	4	O
M_P, M_{A2}, M_{B2}	Control pressure measuring	DIN 3852-1 M14 × 1.5; 12 deep	315	X
M_{A3}, M_{B3}	Control pressure measuring	DIN 3852-1 G 1/4 in	315	X
R₂ ... R₇	Air bleeding the stroking chamber	DIN 3852-1 M14 × 1.5; 12 deep	315	X

1) Depending on the application, momentary pressure peaks can occur. Keep this in mind when selecting measuring devices and fittings.

2) O = Must be connected (plugged on delivery)
 X = Plugged (in normal operation)

EO2M – Suitable for use under fluid

Type	NG	40	71	125	180	250	355	500	750	1000	
A4VSO		•	•	•	•	•	•	•	•	•	EO2M

The **EO2M** variant corresponds to the EO2 version, but without proportional valve, but with pilot pressure ports **X₁** and **X₂**.

The proportional valve can be positioned separately in the system and piped up via the designated ports **X₁** and **X₂** of the pump.

The unit can be installed in the reservoir together with the

directly mounted position transducer.

Approved for HLP fluids DIN 51524.

With the separately placed valve (type see page 67) and a separate VT3025-1x amplifier according to data sheet 29955, an analog EO pump control system can be installed.

Technical data EO2M

Size		NG	40	71	125	180	250	355	500	750	1000
Control pressure (in X₁ , X₂)	p_{\min}	bar	50	50	50	100	100	100	125	125	125
	$p_{\max}^{1)}$	bar	315	315	315	315	315	315	315	315	315
Control stroke	s_{\max}	mm	14.2	17.1	20.7	20.7	25.9	25.9	32.6	37.0	41.4
Control area	A	cm ²	8.1	12.6	18.1	18.1	28.3	28.3	38.2	56.8	63.6
Control volume	$V_{S \max}$	cm ³	11.4	21.5	37.5	37.5	73.2	73.2	124.5	210	263.3
Weight approx. (A4VSO...EO2M...N00)	m	kg	42	59	98	122	200	220	338	481	611

1) Due to the permissible data of the proportional valve

Circuit diagrams EO2M – size 40 to 355

To minimize the control fluid consumption, the stroking chambers are sealed in sizes 125...355 and can be bled via the ports **R₂** to **R₇**.

▼ **Sizes 40 and 71**

Example: open circuit A4VSO

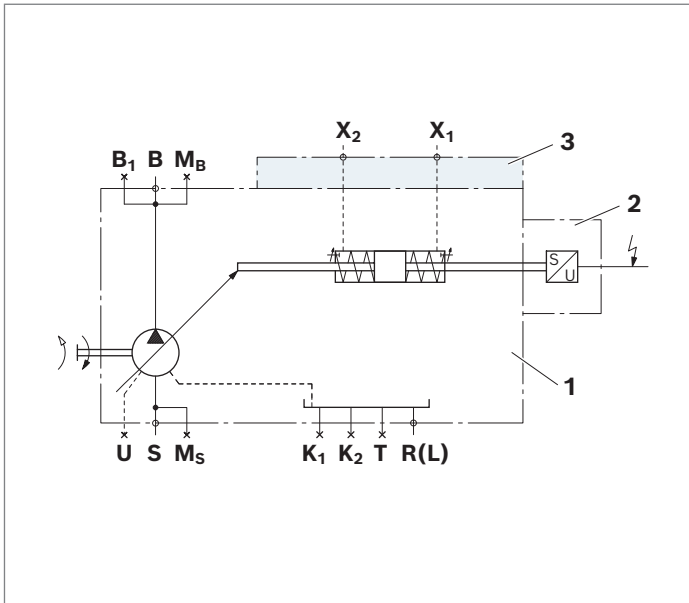

Circuit diagram EO2M – size 500 to 1000

To minimize the control fluid consumption, the stroking chambers are sealed and can be bled via the ports **R₂** to **R₇**.

▼ **Sizes 500 to 1000**

Example: closed circuit A4VSO

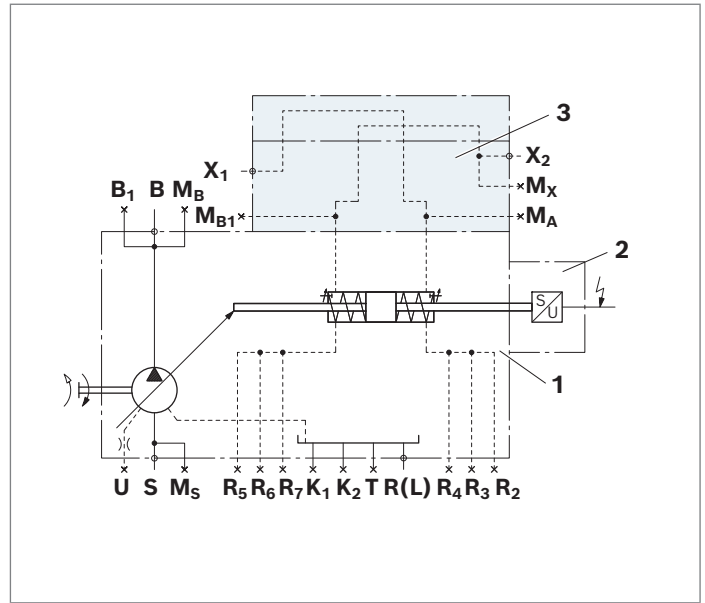

▼ **Sizes 125 to 355**

Example: open circuit A4VSO

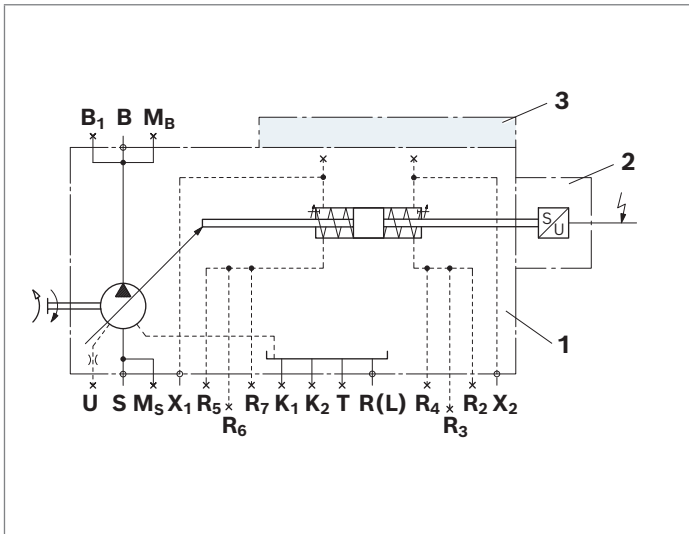

- 1 Pump with hydraulic control device (see data sheet 92050)
- 2 Inductive position transducer AWXX004D02¹⁾
- 3 Intermediate plate

Dimensions EO2M

▼ **A4VSO, size 40 to 355**

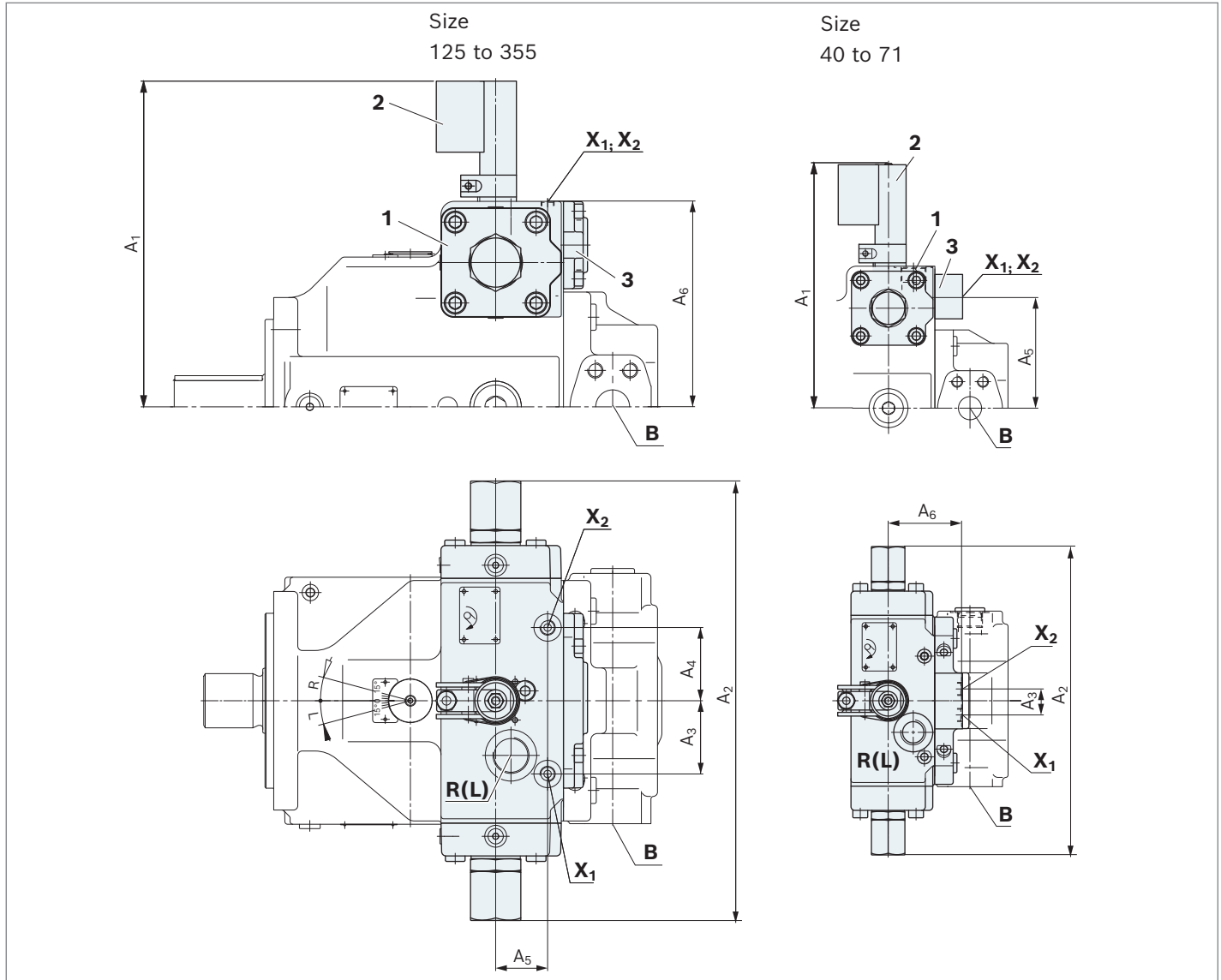

NG	A ₁	A ₂	A ₃	A ₄	A ₅	A ₆	
40/71	264.5	332	28	–	119.5	79	For detailed dimensions and technical data for the variable pump, see data sheet 92050 (A4VSO)
125/180	298	402	67	67	47.5	186.5	
250/355	345	485	71	71	62.5	233	

Ports		Standard	Size	p _{max} [bar] ¹⁾	State ²⁾
X ₁ , X ₂	Pilot pressure	DIN 3852-1	M14 x 1.5; 12 deep (NG 40 and 180) M18 x 1.5; 12 deep (NG 250 and 355)	315 315	O O

1) Depending on the application, momentary pressure peaks can occur. Keep this in mind when selecting measuring devices and fittings.

2) O = Must be connected (plugged on delivery)
X = Plugged (in normal operation)

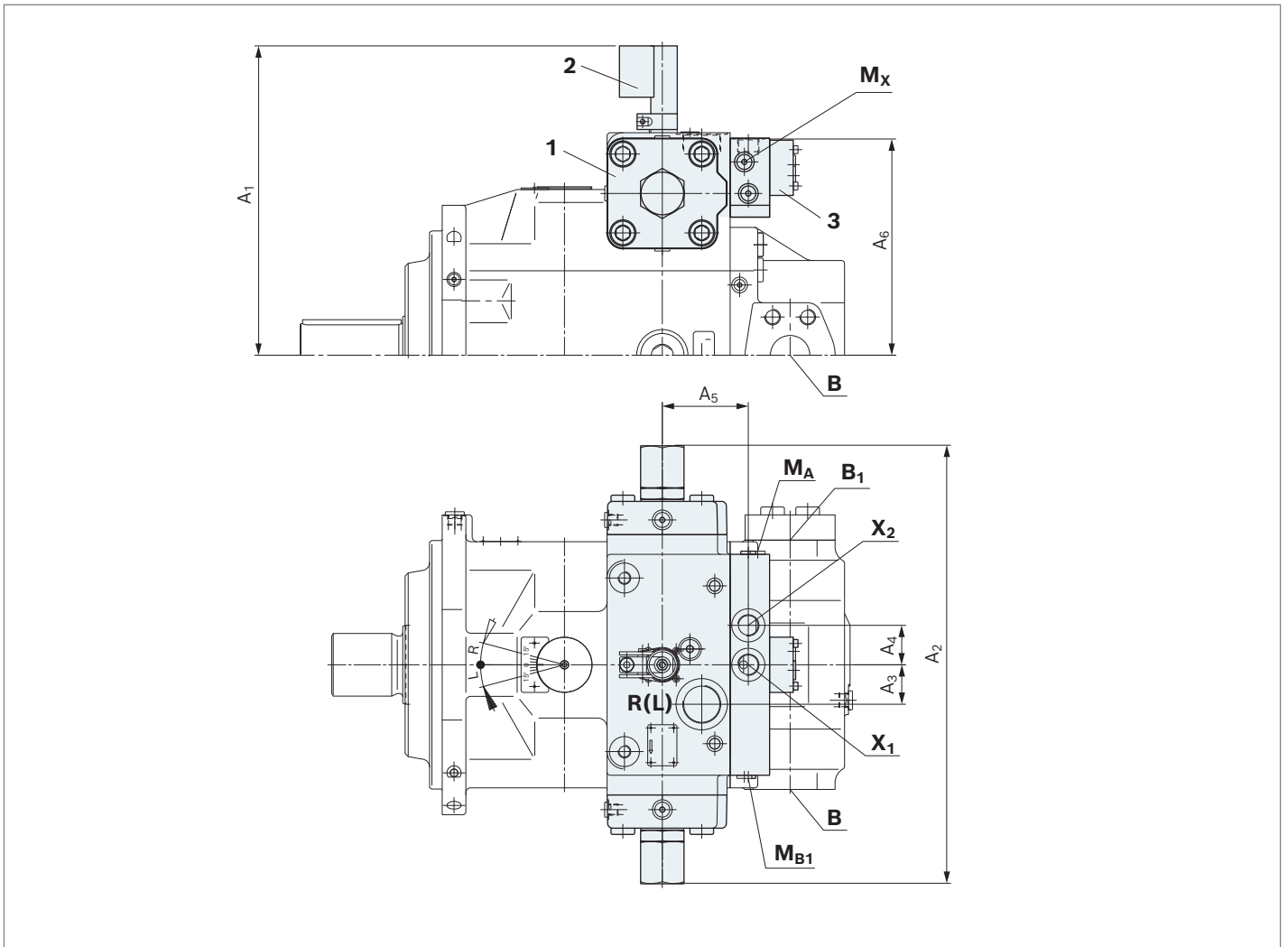
▼ **A4VSO, sizes 500 to 750**

NG	A ₁	A ₂	A ₃	A ₄	A ₅	A ₆	
500	392	555	50	50	109	274	For detailed dimensions and technical data for the variable pump, see data sheet 92050 (A4VSO)
750	427	630	50	50	119	304	

Ports		Standard	Size	p_{\max} [bar] ¹⁾	State ²⁾
X ₁ , X ₂	Pilot pressure	DIN 3852-1	M27 × 2; 16 deep	315	O
M _A , M _{B1} , M _X	Control pressure measuring	DIN 3852-1	M14 × 1.5; 12 deep (NG 500)	315	X

1) Depending on the application, momentary pressure peaks can occur. Keep this in mind when selecting measuring devices and fittings.

2) O = Must be connected (plugged on delivery)
X = Plugged (in normal operation)

Project planning notes

- ▶ The control devices HM, HS5 and EO are designed for use in the open circuit (A4VSO, A4VBO) or closed circuit (A4VSG, A4CSG) depending on the pump.
- ▶ Project planning, installation and commissioning of the axial piston units requires the involvement of skilled personnel.
- ▶ Before using the axial piston unit, please read the corresponding instruction manual completely and thoroughly. If necessary, this can be requested from Bosch Rexroth.
- ▶ Before finalizing your design, request a binding installation drawing. If you need a 3D installation model, please consult the responsible contact person at Bosch Rexroth.
- ▶ The specified data and notes contained herein must be observed.
More information on the products can be found in the data sheets listed on page 1.
- ▶ Depending on the operating conditions of the axial piston unit (working pressure, fluid temperature), the characteristic curve may shift.
- ▶ The characteristic curve may also shift due to the dither frequency or control electronics.
- ▶ Preservation: Our axial piston units are supplied as standard with preservation protection for a maximum of 12 months. If longer preservation protection is required (maximum 24 months), please specify this in plain text when placing your order. The preservation periods apply under optimal storage conditions, details of which can be found in the data sheet 90312 or the instruction manual.
- ▶ Not all configuration variants of the product are approved for use in safety functions according to ISO 13849. Please consult the proper contact at Bosch Rexroth if you require reliability parameters (e.g. $MTTF_d$) for functional safety.
- ▶ Depending on the type of control used, electromagnetic effects can be produced when using solenoids. Use of the recommended direct current (DC) on the electromagnet does not produce any electromagnetic interference (EMI) nor is the electromagnet influenced by EMI. A possible electromagnetic interference (EMI) exists if the solenoid is supplied with modulated direct current (e.g. PWM signal). The machine manufacturer should conduct appropriate tests and take appropriate measures to ensure that other components or operators (e.g. with a pacemaker) are not affected by this potentiality.
- ▶ Pressure controllers are not safeguards against pressure overload. Be sure to add a pressure relief valve to the hydraulic system.
- ▶ For drives that are operated for a long period of time with constant rotational speed, the natural frequency of the hydraulic system can be stimulated by the excitation frequency of the pump (rotational speed frequency x 9). This can be prevented with suitably designed hydraulic lines.
- ▶ For controllers requiring external pilot pressure, sufficient control fluid must be provided to the associated ports to ensure the required pilot pressures for the respective controller function. These controllers are subject to leakage due to their design. An increase in control fluid demand has to be anticipated over the total operating time. The design of the control fluid supply must thus be sufficiently large. If the control fluid is too low, the respective controller function may be impaired and undesired system behavior may result.
- ▶ Please note the details regarding the tightening torques of port threads and other threaded joints in the instruction manual.
- ▶ The ports and fastening threads are designed for the p_{max} permissible pressures of the respective ports, see the connection tables. The machine or system manufacturer must ensure that the connecting elements and lines correspond to the specified application conditions (pressure, flow, hydraulic fluid, temperature) with the necessary safety factors.
- ▶ The working ports and function ports are only intended to accommodate hydraulic lines.

Installation instructions

The installation instructions for the relevant variable pump apply:

- ▶ A4VSO, data sheet 92050
- ▶ A4VBO, data sheet 92122
- ▶ A4VSG, data sheet 92100
- ▶ A4CSG, data sheet 92105

Only the controls **HM1**, **HM2**, **EO2M** and **HS5M** are suitable for use under fluid.

Safety instructions

- ▶ During and shortly after operation, there is a risk of burning on the axial piston unit and especially on the solenoids. Take the appropriate safety measures (e.g. by wearing protective clothing).
- ▶ Moving parts in control equipment (e.g. valve spools) can, under certain circumstances, get stuck in position as a result of contamination (e.g. contaminated hydraulic fluid, abrasion, or residual dirt from components). As a result, the hydraulic fluid flow and the build-up of torque in the axial piston unit can no longer respond correctly to the operator's specifications. Even the use of various filter elements (external or internal flow filtration) will not rule out a fault but merely reduce the risk. The machine/system manufacturer should test whether additional measures are required on the machine for the relevant application in order to bring the driven consumer into a safe position (e.g. safe stop) and make sure any measures are properly implemented.

Related documentation

Product-specific documentation

Document type	Title	Document number
Data sheet	Axial piston variable pump A4VSO series 1x and 3x	92050
	Axial piston variable pump A4VSG series 1x and 3x	92100
	Axial piston variable pump A4CSG series 3x	92105
	Axial piston variable pump A4VBO series 1x and 3x	92122
Instruction manuals	Axial piston variable pump A4VSO series 1x and 3x	92050-01-B
	Axial piston variable pump A4VSG series 1x and 3x	92100-01-B
	Axial piston variable pump A4CSG series 3x	92105-01-B
	Axial piston variable pump A4VBO series 1x and 3x	92122-01-B
	Control system HS5E(V)(L) for Axial piston variable pump A4VSO, A4VBO, A4VSG and A4CSG	92076-01-B
	VT-HPC-1-1X Digital control electronics for axial piston pumps	30237-B

Documentation for control valves and control electronics

Control	Title	Document number
HM2C	4/2 and 4/3 proportional directional valves direct operated, with electric position feedback, without/with integrated electronics (OBE)	29061
HS5.../HS5M/HS5V/HS5L	Pressure transducer for hydraulic applications; type HM20	30272
	Digital control electronics for axial piston pumps; type VT-HPC	30237
	Directional control valves, direct operated, without electric position feedback; type 4WRPH	29027
HS5E.../HS5EV/HS5EL	Swivel angle sensor; type ASSEMBLY KIT VT-SWA-LIN	30263
	Compact power supply units VT-NE30, unit series 2X, VT-NE31, unit series 1X	29929
	Directional spool valves, direct operated, with solenoid actuation; type Z4WE	23193
	4/2 and 4/3 directional shut-off valves, internally pilot operated, externally pilot operated; type Z4WEH and Z4WH	24753
	Electric amplifier for 1/8 flow adjuster with proportional valves; type VT 5035	29955
	Electric amplifiers; type VT-VSPA1-5...-1X/V0/RTP	29055
	Plug-in connectors and wiring harnesses for valves and sensors in hydraulic systems	08006
	Rexroth HydraulicDrive; HDx-20 pump control	30237-Z

Documentation for hydraulic fluids

Document type	Title	Document number
Data sheet	Hydraulic fluids based on mineral oils and related hydrocarbons	90220
	Environmentally acceptable hydraulic fluids	90221
	Bosch Rexroth Fluid Rating List for Rexroth hydraulic components (pumps and motors)	90245

Bosch Rexroth AG

An den Kelterwiesen 14
72160 Horb a.N.
Germany
Tel. +49 7451 92-0
sales.industry.horb@boschrexroth.de
www.boschrexroth.com

© Bosch Rexroth AG 1993. All rights reserved, also regarding any disposal, exploitation, reproduction, editing, distribution, as well as in the event of applications for industrial property rights. The data specified within only serves to describe the product. No statements concerning a certain condition or suitability for a certain application can be derived from our information. The information given does not release the user from the obligation of own judgment and verification.. It must be remembered that our products are subject to a natural process of wear and aging.