

Axial piston variable pump A11V(L)O series 1x

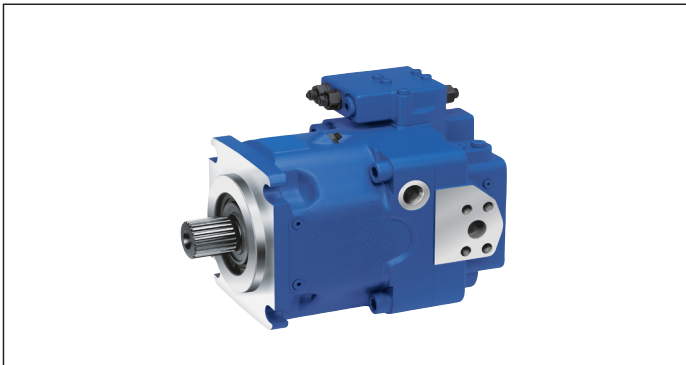

- ▶ All-purpose high pressure pump
- ▶ Size 40 ... 260
- ▶ Nominal pressure 350 bar
- ▶ Maximum pressure 400 bar
- ▶ Open circuit

Features

- ▶ Through-drive for mounting of further pumps up to same size
- ▶ Optional with charge pump for sizes 130 ... 260
- ▶ Higher speeds are possible for the version with charge pump (A11VLO)
- ▶ Large variety of controls
- ▶ Swashplate design
- ▶ Compact design
- ▶ High efficiency
- ▶ High power density

Contents

Type code	2
Hydraulic fluid	5
Working pressure range	7
Technical data	8
Power controller	11
Pressure controller	22
Hydraulic control, pilot-pressure related	26
Electrical control with proportional solenoid	28
Dimensions, size 40	32
Dimensions, size 60	36
Dimensions, size 75	40
Dimensions, size 95	44
Dimensions, size 130/145	48
Dimensions, size 190	52
Dimensions, size 260	57
Dimensions, through-drive	62
Overview of mounting options	65
Combination pumps A11V(L)O + A11V(L)O	66
Swivel angle indicator	67
Connector for solenoids	69
Installation instructions	70
Project planning notes	74
Safety instructions	75

Type code

01	02	03	04	05	06	07	08	09	10	11	12	13	14	15
A11V				/			N			12				-

Axial piston unit

01	Swashplate design, variable, nominal pressure 350 bar, maximum pressure 400 bar	A11V
----	---	-------------

Operating mode

		40	60	75	95	130	145	190	260
02	Pump, open circuit								
	without charge pump	●	●	●	●	●	●	●	●
	with charge pump	-	-	-	-	●	●	●	●
									O
									LO

Sizes (NG)

03	Geometric displacement, see technical data on page 8	40	60	75	95	130	145	190	260
----	--	-----------	-----------	-----------	-----------	------------	------------	------------	------------

Control device¹⁾

		40	60	75	95	130	145	190	260
04	Power controller								
	fixed setting	●	●	●	●	●	●	●	●
	with override								
	cross sensing	●	●	●	●	●	●	●	●
	negative control	●	●	●	●	●	●	●	●
	high pressure dependent	●	●	●	●	●	●	●	●
	negative control	●	●	●	●	●	●	●	●
	pilot-pressure related	●	●	●	●	●	●	●	●
	negative control	●	●	●	●	●	●	●	●
	positive control	●	●	●	●	●	●	●	●
	electric	●	●	●	●	●	●	●	●
	negative control	●	●	●	●	●	●	●	●
	$U = 24\text{ V}$	●	●	●	●	●	●	●	●
	LR								
	with pressure cut-off	●	●	●	●	●	●	●	●
hydraulic remote controlled	●	●	●	●	●	●	●	●	
L.D..									
with load sensing	●	●	●	●	●	●	●	●	
L...S									
electric proportional override	●	●	●	●	●	●	●	●	
$U = 24\text{ V}$	●	●	●	●	●	●	●	●	
hydraulic proportional override	-	-	-	●	●	●	●	●	
L...S2									
L...S5									
with stroke limiter	●	●	●	●	●	●	●	●	
negative control	●	●	●	●	●	●	●	●	
$\Delta p = 25\text{ bar}$	●	●	●	●	●	●	●	●	
positive control	●	●	●	●	●	●	●	●	
$\Delta p = 25\text{ bar}$	●	●	●	●	●	●	●	●	
$U = 24\text{ V}$	●	●	●	●	●	●	●	●	
L...H1									
L...H2									
L...U2									
with manual override and spring return	○	○	○	○	○	○	○	○	
$U = 24\text{ V}$	○	○	○	○	○	○	○	○	
L...U6									
Pressure controller	●	●	●	●	●	●	●	●	
DR									
with load sensing	●	●	●	●	●	●	●	●	
DRS									
hydraulic remote controlled	●	●	●	●	●	●	●	●	
DRG									
for parallel operation	●	●	●	●	●	●	●	●	
DRL									
Hydraulic control, pilot-pressure related	●	●	●	●	●	●	●	●	
positive control	●	●	●	●	●	●	●	●	
$\Delta p = 25\text{ bar}$	●	●	●	●	●	●	●	●	
with pressure cut-off	●	●	●	●	●	●	●	●	
$\Delta p = 25\text{ bar}$	●	●	●	●	●	●	●	●	
HD2									
HD2D									
Electrical control with proportional solenoid	●	●	●	●	●	●	●	●	
positive control	●	●	●	●	●	●	●	●	
$U = 24\text{ V}$	●	●	●	●	●	●	●	●	
with manual override and spring return	○	○	○	○	○	○	○	○	
$U = 24\text{ V}$	○	○	○	○	○	○	○	○	
EP2									
EP6									
with pressure cut-off	●	●	●	●	●	●	●	●	
EP2D									
hydraulic remote controlled	●	●	●	●	●	●	●	●	
EP2G									
with pressure cut-off, electric remote controlled	-	-	-	●	●	●	●	●	
positive control	-	-	-	●	●	●	●	●	
EP2G2									
negative control	-	-	-	●	●	●	●	●	
EP2G4									

● = Available ○ = On request - = Not available

1) The following combinations are not available with the power controller: LRDS2, LRDS5, L...GS, L...GS2, L...GS5 and the combination L...DG in conjunction with the stroke limiters H1, H2, H5, U2, U6.

01	02	03	04	05	06	07	08	09	10	11	12	13	14	15
A11V			/				N			12				-

Series

05		1
----	--	---

Index

06	Size 40 ... 130	0
	Size 145 ... 260	1

Direction of rotation

07	Viewed on drive shaft	clockwise	R
		counter-clockwise	L

Seals

08	NBR (nitrile rubber), shaft seal ring made of FKM (fluorocarbon rubber)	N
	FKM (fluorocarbon rubber)	V

Drive shafts (for permissible input torque, see page 10)

		40	60	75	95	130	145	190	260		
09	Splined shaft DIN 5480 for single and combination pump	●	●	●	●	●	●	●	●	Z	
	Parallel keyed shaft DIN 6885	●	●	●	●	●	●	●	●	P	
	Splined shaft ANSI B92.1a-1976	for single pump	●	●	●	●	●	●	●	●	S
		for combination pump	●	●	●	⊖ ²⁾	⊖ ²⁾	⊖ ²⁾	●	●	T

Mounting flange

		40	60	75	95	130	145	190	260	
10	SAE J744 – 2-hole	●	●	–	–	–	–	–	–	C
	SAE J744 – 4-hole	–	–	●	●	●	●	●	●	D
	SAE J617 ³⁾ (SAE 3)	–	–	–	●	●	●	●	–	G

Working port (connection thread and fastening thread)

		40	60	75	95	130	145	190	260	
11	SAE pressure and suction port at side, opposite, metric fastening thread according to DIN 13. Fastening thread, metric with profile sealing ring based on DIN 3852	●	●	●	●	●	●	●	●	12
	SAE pressure and suction port at side, opposite, metric fastening thread according to DIN 13. Fastening thread, UNF with profile sealing ring based on ISO 11926	○	●	●	●	●	●	●	●	07

● = Available ○ = On request – = Not available

2) S-shaft suitable for combination pump!
3) Suitable for flywheel housing of the internal combustion engine

4 **A11V(L)O series 1x** | Axial piston variable pump
Type code

01	02	03	04	05	06	07	08	09	10	11	12	13	14	15
A11V			/				N			12			P	-

Through-drives (for mounting options, see page 62)

12	Flange SAE J744 ⁴⁾	Hub for splined shaft ⁴⁾			40	60	75	95	130	145	190	260		
	Diameter	Diameter	Designation											
	-	-			●	●	●	●	●	●	●	●	N00	
82-2 (A)	5/8 in	9T 16/32DP	A	●	●	●	●	●	●	●	●	●	K01	
		3/4 in	11T 16/32DP	A-B	●	●	●	●	●	●	●	●	K52	
101-2 (B)	7/8 in	13T 16/32DP	B	●	●	●	●	●	●	●	●	●	K02	
		1 in	15T 16/32DP	B-B	●	●	●	●	●	●	●	●	K04	
		W 35 × 2 × 16 × 9g			●	●	●	●	○	○	●	●	●	K79
127-2/-2+4 (C) ⁵⁾	1 1/4 in	14T 12/24DP	C	-	●	●	●	●	●	●	●	●	K07	
		1 1/2 in	17T 12/24DP	C-C	-	-	-	●	●	●	●	●	K24	
		W 30 × 2 × 14 × 9g			-	●	●	●	● ⁶⁾	● ⁶⁾	●	●	●	K80
		W 35 × 2 × 16 × 9g			-	●	●	●	●	●	●	●	●	K61
152-4 (D)	1 1/4 in	14T 12/24DP	C	-	-	●	●	●	●	●	●	●	K86	
		1 3/4 in	13T 8/16DP	D	-	-	-	-	●	●	●	●	K17	
		W 40 × 2 × 18 × 9g			-	-	●	●	●	●	●	●	●	K81
		W 45 × 2 × 21 × 9g			-	-	-	●	●	●	●	●	●	K82
		W 50 × 2 × 24 × 9g			-	-	-	-	●	●	●	●	●	K83
165-4 (E)	1 3/4 in	13T 8/16DP	D	-	-	-	-	-	-	-	●	●	K72	
		W 50 × 2 × 24 × 9g			-	-	-	-	-	-	-	●	●	K84
		W 60 × 2 × 28 × 9g			-	-	-	-	-	-	-	-	●	K67

Swivel angle indicator (see page 68)

13		40	60	75	95	130	145	190	260	
	without swivel angle indicator (without code)	●	●	●	●	●	●	●	●	
	with optical swivel angle indicator	●	-	●	●	●	●	●	●	V
	with electric swivel angle sensor	●	-	●	●	●	●	●	●	R

Connector for solenoids (see page 69)

14		40	60	75	95	130	145	190	260	
	DEUTSCH connector molded	●	●	●	●	●	●	●	●	P
	2-pin, without suppressor diode									

Standard/special version

15		
	Standard version (without code)	
	Special version	S
	Installation variant	Y

● = Available ○ = On request - = Not available

4) 2 ≙ 2-hole; 4 ≙ 4-hole

5) NG190 and NG260 with 2 + 4 hole flange

6) Not available for version with charge pump

Hydraulic fluid

The axial piston unit is designed for operation with HLP mineral oil according to DIN 51524. Application instructions and requirements for hydraulic fluid selection, behavior during operation as well as disposal and environmental protection should be taken from the following data sheets before the start of project planning:

- ▶ 90220: Hydraulic fluids based on mineral oils and related hydrocarbons
- ▶ 90221: Environmentally acceptable hydraulic fluids
- ▶ 90223: Fire-resistant, water-containing hydraulic fluids (HFC/HFB/HFAE/HFAS)

Selection of hydraulic fluid

Bosch Rexroth evaluates hydraulic fluids on the basis of the Fluid Rating according to the technical data sheet 90235.

Hydraulic fluids with positive evaluation in the Fluid Rating are provided in the following technical data sheet:

- ▶ 90245: Bosch Rexroth Fluid Rating List for Rexroth hydraulic components (pumps and motors)

Selection of hydraulic fluid shall make sure that the operating viscosity in the operating temperature range is within the optimum range (v_{opt} ; see selection diagram).

Viscosity and temperature of hydraulic fluids

	Viscosity	Shaft seal	Temperature ³⁾	Remarks
Cold start	$v_{max} \leq 1600 \text{ mm}^2/\text{s}$	NBR ²⁾	$\vartheta_{St} \geq -40 \text{ }^\circ\text{C}$	$t \leq 3 \text{ min}$, without load ($p \leq 50 \text{ bar}$), $n \leq 1000 \text{ rpm}$ Permissible temperature difference between axial piston unit and hydraulic fluid in the system maximum 25 K
		FKM	$\vartheta_{St} \geq -25 \text{ }^\circ\text{C}$	
Warm-up phase	$v = 1600 \dots 400 \text{ mm}^2/\text{s}$			$t \leq 15 \text{ min}$, $p \leq 0.7 \times p_{nom}$ and $n \leq 0.5 \times n_{nom}$
Continuous operation	$v = 400 \dots 10 \text{ mm}^2/\text{s}^1)$	NBR ²⁾	$\vartheta \leq +85 \text{ }^\circ\text{C}>$	Measured at port T
		FKM	$\vartheta \leq +110 \text{ }^\circ\text{C}>$	
	$v_{opt} = 36 \dots 16 \text{ mm}^2/\text{s}$			Optimal operating viscosity and efficiency range
Short-term operation	$v_{min} = 10 \dots 7 \text{ mm}^2/\text{s}$	NBR ²⁾	$\vartheta \leq +85 \text{ }^\circ\text{C}>$	$t \leq 3 \text{ min}$, $p \leq 0.3 \times p_{nom}$, measured at port T
		FKM	$\vartheta \leq +110 \text{ }^\circ\text{C}>$	

▼ Selection diagram

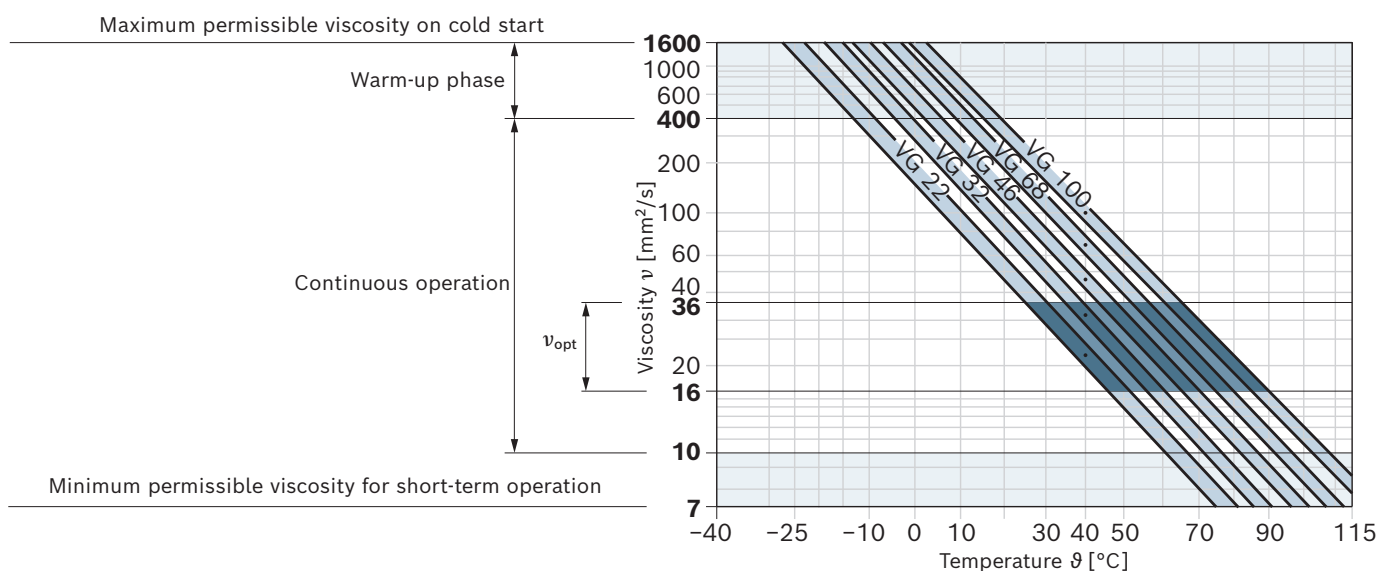

1) This corresponds, for example on the VG 46, to a temperature range of +4 °C to +85 °C (see selection diagram)

2) Special version, please contact us

3) If the temperature at extreme operating parameters cannot be adhered to, please contact us.

Filtration of the hydraulic fluid

Finer filtration improves the cleanliness level of the hydraulic fluid, which increases the service life of the axial piston unit.

A cleanliness level of at least 20/18/15 is to be maintained according to ISO 4406.

At a hydraulic fluid viscosity of less than 10 mm²/s (e.g. due to high temperatures during short-term operation) at the drain port, a cleanliness level of at least 19/17/14 according to ISO 4406 is required.

For example, a viscosity of 10 mm²/s corresponds to the following temperatures with the following media:

- ▶ HLP 32 a temperature of 73 °C
- ▶ HLP 46 corresponds to a temperature of 85 °C

Case flushing

If a variable displacement pump with control device EP, HD or with stroke limiter (H1, H2, U2, U6) is operated for a longer period of time ($t > 10$ min) with zero flow or working pressure < 15 bar, housing flushing via the connections **T₁**, **T₂** or **R** is required.

NG	40	60	75	95	130	145	190	260
$q_{V \text{ flush}}$ (l/min)	2	3	3	4	4	4	5	6

The need for housing flushing is eliminated at the version with charge pump (A11VLO).

Charge pump (impeller)

The charge pump is a centrifugal pump with which the A11VLO is filled and therefore can be operated at higher rotational speeds. This also simplifies cold starting at low temperatures and high viscosity of the hydraulic fluid. Externally increasing the inlet pressure is therefore unnecessary in most cases. Charging the reservoir with compressed air is permissible at 2 bar absolute.

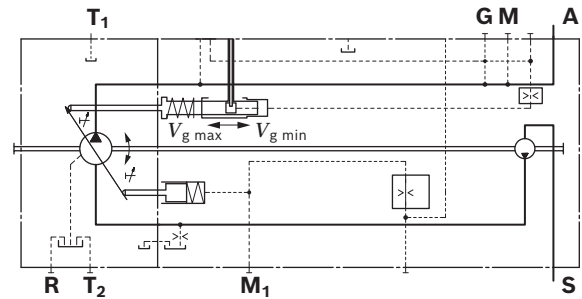

Working pressure range

Pressure at port for working line A		Definition
Nominal pressure p_{nom}	350 bar	The nominal pressure corresponds to the maximum design pressure.
Maximum pressure p_{max}	400 bar	The maximum pressure corresponds to the maximum working pressure within a single operating period. The sum of single operating periods must not exceed the total operating period.
Single operating period	< 1 s	
Total operating period	300 h	
Minimum pressure p_A absolute (high-pressure side)	see diagram "Minimum pressure (high-pressure side)"	Minimum pressure at the high-pressure side A which is required in order to prevent damage to the axial piston unit.
Rate of pressure change $R_{A\ max}$	16000 bar/s	Maximum permissible speed of pressure build-up and reduction during a pressure change across the entire pressure range.
Pressure at suction port S (inlet)		
Version without charge pump		
Minimum pressure $p_{S\ min}$	≥ 0.8 bar absolute	Minimum pressure at suction port S (inlet) which is required to prevent damage to the axial piston unit. The minimum pressure is dependent on the rotational speed and displacement of the axial piston unit (see diagram "Maximum permissible rotational speed" on page 9).
Maximum pressure $p_{S\ max}$	≤ 30 bar absolute ¹⁾	
Version with charge pump		
Minimum pressure $p_{S\ min}$	≥ 0.6 bar absolute	Minimum pressure at suction port S (inlet) which is required to prevent damage to the axial piston unit.
Maximum pressure $p_{S\ max}$	≤ 2 bar absolute	
Case pressure at port T ₁ , T ₂		
Maximum case pressure $p_{T\ max}$	2 bar	Measured at port T₁ , T₂ Maximum 1.2 bar higher than inlet pressure at port S , but not higher than $p_{T\ max}$. A drain line to the reservoir is required.

Minimum pressure (high-pressure side)

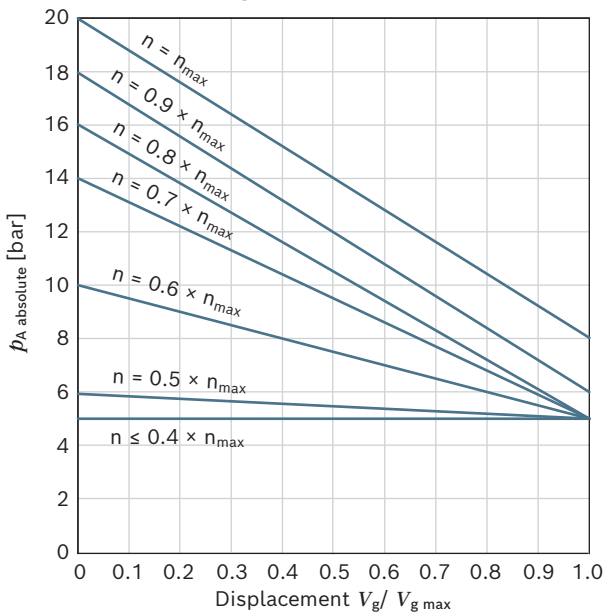

1) > 5 bar, please contact us

Pressure definition

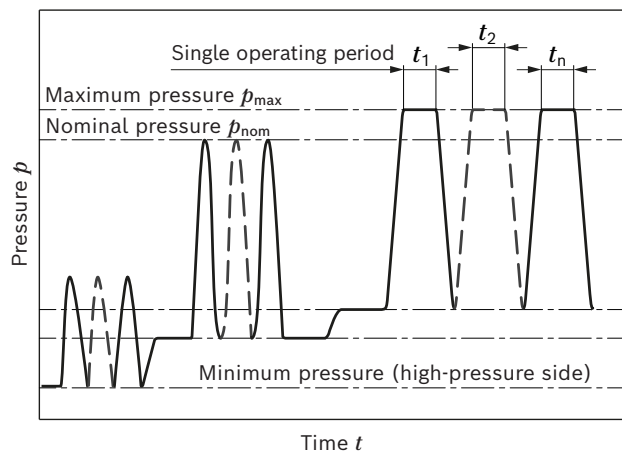

$$\text{Total operating period} = t_1 + t_2 + \dots + t_n$$

Notice

- ▶ Working pressure range applies when using hydraulic fluids based on mineral oils. Please contact us for values for other hydraulic fluids.
- ▶ The case pressure must be greater than the external pressure (ambient pressure) at the shaft seal.

Technical data

Without charge pump (A11VO)

Size	NG		40	60	75	95	130	145	190	260	
Geometric displacement, per revolution	$V_{g \max}$	cm ³	42.0	58.5	74.0	93.5	130.0	145.0	193.0	260.0	
	$V_{g \min}$	cm ³	0	0	0	0	0	0	0	0	
Maximum rotational speed	at $V_{g \max}^{1)}$	n_{nom}	rpm	3000	2700	2550	2350	2100	2200	2100	2000
	at $V_{g \leq V_{g \max}^{3)}$	n_{max}	rpm	3500	3250	3000	2780	2500	2500	2100 ⁵⁾	2300
Flow	at n_{nom} and $V_{g \max}$	q_v	l/min	126	158	189	220	273	319	405	468
Power	at n_{nom} , $V_{g \max}$ and $\Delta p = 350$ bar	P	kW	74	92	110	128	159	186	236	273
Torque	at $V_{g \max}$ and $\Delta p = 350$ bar ²⁾	M	Nm	234	326	412	521	724	808	1075	1448
Rotary stiffness drive shaft	Z	c	kNm/rad	88.9	102.4	145.8	199.6	302.5	302.5	346.2	686.5
	P	c	kNm/rad	87.5	107.9	143.1	196.4	312.4	312.4	383.2	653.8
	S	c	kNm/rad	58.3	86.3	101.9	173.7	236.9	236.9	259.8	352.0
	T	c	kNm/rad	74.5	102.4	125.6	148.3	–	–	301.9	567.1
Moment of inertia of the rotary group	J_{TW}	kgm ²	0.0048	0.0082	0.0115	0.0173	0.0318	0.0341	0.055	0.0878	
Maximum angular acceleration ⁴⁾	α	rad/s ²	22000	17500	15000	13000	10500	9000	6800	4800	
Case volume	V	L	1.1	1.35	1.85	2.1	2.9	2.9	3.8	4.6	
Weight (without through-drive) approx.	m	kg	32	40	45	53	66	67	95	125	

With charge pump (A11VLO)

Size	NG		130	145	190	260	
Geometric displacement, per revolution	$V_{g \max}$	cm ³	130.0	145.0	193.0	260.0	
	$V_{g \min}$	cm ³	0	0	0	0	
Maximum rotational speed	at $V_{g \max}^{2)}$	n_{nom}	rpm	2500	2500	2500	2300
	at $V_{g \leq V_{g \max}^{3)}$	n_{max}	rpm	2500	2500	2500	2300
Flow	at n_{nom} and $V_{g \max}$	q_v	l/min	325	363	483	598
Power	at n_{nom} , $V_{g \max}$ and $\Delta p = 350$ bar	P	kW	190	211	281	349
Torque	at $V_{g \max}$ and $\Delta p = 350$ bar ²⁾	M	Nm	724	808	1075	1448
Rotary stiffness drive shaft	Z	c	kNm/rad	302.5	302.5	346.2	686.5
	P	c	kNm/rad	312.4	312.4	383.3	653.8
	S	c	kNm/rad	236.9	236.9	259.8	352.0
	T	c	kNm/rad	–	–	301.9	567.1
Moment of inertia of the rotary group	J_{TW}	kgm ²	0.0337	0.036	0.0577	0.0895	
Maximum angular acceleration ⁴⁾	α	rad/s ²	10500	9000	6800	4800	
Case volume	V	L	2.9	2.9	3.8	4.6	
Weight (without through-drive) approx.	m	kg	72	73	104	138	

- 1) The values apply for an absolute pressure (p_{absolute}) of 1 bar at suction port **S** and for operation with mineral operating fluid.
- 2) The values apply for an absolute pressure (p_{absolute}) of at least 0.8 bar at suction port **S** and for operation with mineral operating fluid.
- 3) The values apply at $V_{g \leq V_{g \max}}$ or when the inlet pressure (p_{absolute}) is increased at the suction port **S** (see diagram "Maximum permissible rotational speed" page 9)

- 4) The scope of application lies between 0 and the maximum permissible rotational speed. It applies for external stimuli (e.g. diesel engine 2 to 8 times rotary frequency, cardan shaft 2 times rotary frequency).
The limit value is only valid for a single pump.
The load capacity of the connection parts must be considered.
- 5) Higher rotational speed possible with special version after consultation.

▼ **Maximum permissible rotational speed (speed limit)**
(p_{absolute} = inlet pressure)

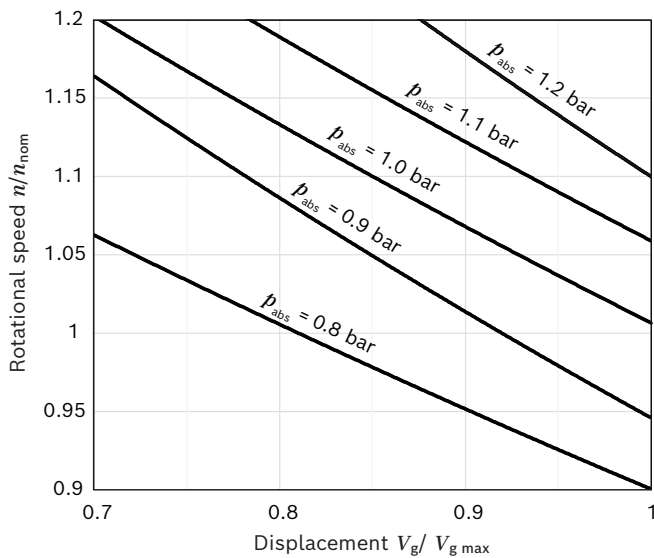

Permissible rotational speed depending on inlet pressure p_{absolute} and displacement volume $V_g/V_{g \text{ max}}$. Observe the max. rotational speed n_{max}

Determination of the characteristics

Flow	$q_v = \frac{V_g \times n \times \eta_v}{1000}$	[l/min]
Torque	$M = \frac{V_g \times \Delta p}{20 \times \pi \times \eta_{hm}}$	[Nm]
Power	$P = \frac{2 \pi \times M \times n}{60000} = \frac{q_v \times \Delta p}{600 \times \eta_t}$	[kW]

Key		
V_g	=	Displacement per revolution [cm ³]
Δp	=	Differential pressure [bar]
n	=	Rotational speed [rpm]
η_v	=	Volumetric efficiency
η_{hm}	=	Hydraulic-mechanical efficiency
η_t	=	Total efficiency ($\eta_t = \eta_v \times \eta_{hm}$)

Permissible radial and axial loading on the drive shafts

Size	NG		40	60	75	95	130	145	190	260
Maximum radial force at distance a, b, c (from shaft collar)	$F_{q \text{ max}}$	N	3600	5000	6300	8000	11000	11000	16925	22000
	a	mm	17.5	17.5	20	20	22.5	22.5	26	29
	$F_{q \text{ max}}$	N	3891	4046	4950	6334	8594	8594	13225	16809
	b	mm	30	30	35	35	40	40	46	50
	$F_{q \text{ max}}$	N	2416	3398	4077	5242	7051	7051	10850	13600
	c	mm	42.5	42.5	50	50	57.5	57.5	66	71
Maximum axial force	$+ F_{ax \text{ max}}$	N	1500	2200	2750	3500	4800	4800	6000	4150
	$- F_{ax \text{ max}}$	N	1500	2200	2750	3500	4800	4800	6000	4150

Notice

- ▶ Theoretical values, without efficiency and tolerances; values rounded.
- ▶ Operation above the maximum values or below the minimum values may result in a loss of function, a reduced service life or in the destruction of the axial piston unit. Bosch Rexroth recommends testing the loads by means of experiment or calculation / simulation and comparison with the permissible values.
- ▶ Special requirements apply in the case of belt drives. Please contact us.

Permissible input and through-drive torques

Size		NG	40	60	75	95	130	145	190	260
Torque at $V_{g \max}$ and $\Delta p = 350 \text{ bar}^1$	M_{\max}	Nm	234	326	412	521	724	808	1075	1448
Maximum input torque on drive shaft ²⁾										
P	$M_{E \max}$	Nm	468	648	824	1044	1448	1448	2226	2787
Shaft key DIN 6885			Ø32	Ø35	Ø40	Ø45	Ø50	Ø50	Ø55	Ø60
Z	$M_{E \max}$	Nm	912	912	1460	2190	3140	3140	3140	5780
DIN 5480			W35	W35	W40	W45	W50	W50	W50	W60
S	$M_{E \max}$	Nm	314	602	602	1640	1640	1640	1640	1640
ANSI B92.1a-1976 (SAE J744)			1 in	1 1/4 in	1 1/4 in	1 3/4 in	1 3/4 in	1 3/4 in	1 3/4 in	1 3/4 in
T	$M_{E \max}$	Nm	602	970	970	–	–	–	2670	4070
ANSI B92.1a-1976 (SAE J744)			1 1/4 in	1 3/8 in	1 3/8 in	–	–	–	2 in	2 1/4 in
Through-drive torque, maximum ³⁾	$M_{D \max}$	Nm	314	521	660	822	1110	1110	1760	2065

▼ **Distribution of torques**

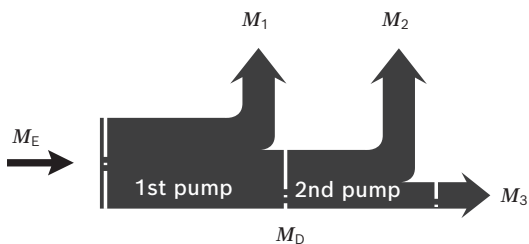

Torque at 1st pump	M_1
Torque at 2nd pump	M_2
Torque at 3rd pump	M_3
Input torque	$M_E = M_1 + M_2 + M_3$
	$M_E < M_{E \max}$
Through-drive torque	$M_D = M_2 + M_3$
	$M_D < M_{D \max}$

1) Efficiency not considered
 2) For drive shafts free of radial force
 3) Note maximum input torque for shaft **S**!

Power controller

LR – Power controller, fixed setting

The power controller regulates the displacement of the pump depending on the working pressure so that a given drive power is not exceeded at constant drive speed. The precise control with a hyperbolic characteristic curve, provides an optimum utilization of available power. The working pressure acts on a rocker via a measuring spool moved together with the control. An externally adjustable spring force counteracts this, it determines the power setting. The depressurized basic position is $V_{g \max}$. If the working pressure exceeds the set spring force, the control valve will be actuated by the rocker and the pump will swivel back from the basic position $V_{g \max}$ toward $V_{g \min}$. Here, the leverage at the rocker may be shortened and the working pressure may rise in the same relation as the displacement is reduced ($p_B \times V_g = \text{constant}$; $p_B = \text{working pressure}$; $V_g = \text{displacement}$).

The hydraulic output power (characteristic curve LR) is influenced by the efficiency of the pump.

Setting range for beginning of control 50 to 350 bar

When ordering, state in plain text:

- ▶ Drive power P [kW]
- ▶ Drive speed n [rpm]
- ▶ Maximum flow $q_{V \max}$ [l/min]

Please contact us if you need a performance chart.

▼ Characteristic curve LR

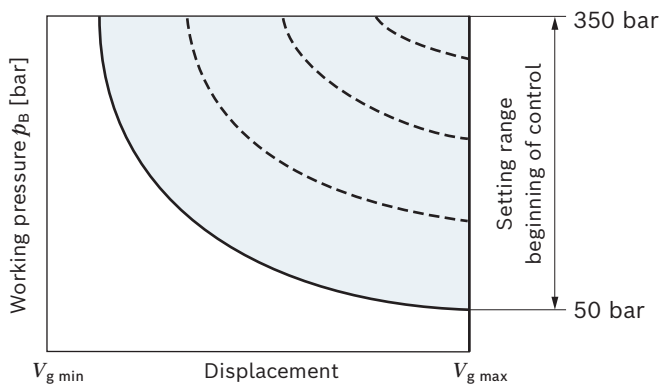

▼ Circuit diagram NG 40 to 145

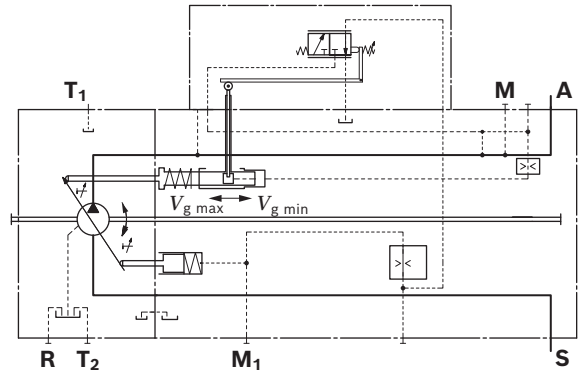

▼ Circuit diagram NG 190 to 260

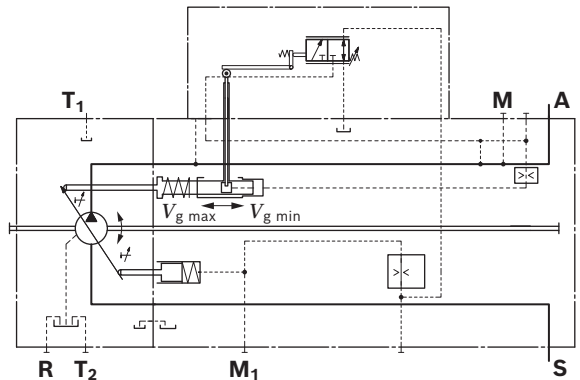

LRC – Override with cross sensing

Cross sensing is total capacity control (high-pressure-dependent) that connects two equally sized A11VO pumps with LRC controllers in power control. If one pump is operating at pressures below the set beginning of control, the unused drive power is available to the other pump, up to 100 % in borderline cases. A total drive power is thus distributed between two consumers according to demand. Freed-up power due to pressure cut-off or other overrides is not taken into account.

Half-sided cross sensing function

When using the LRC controller on the 1st pump (A11VO) and a power-controlled pump with through-drive and without cross-sensing, which is also mounted at the drive, the required power for the 2nd pump deducted from the settings of the 1st pump. The 2nd pump has priority in the total power setting. For design of the controller of the 1st pump, the size and the beginning of control of the power controller of the 2nd pump are required.

▼ Circuit diagram NG 40 to 145

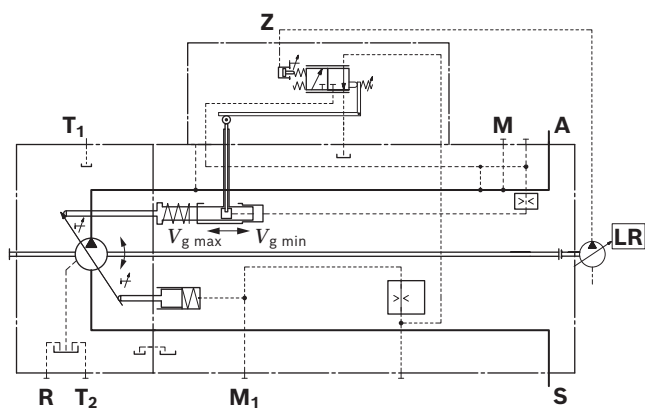

▼ Circuit diagram NG 190 to 260

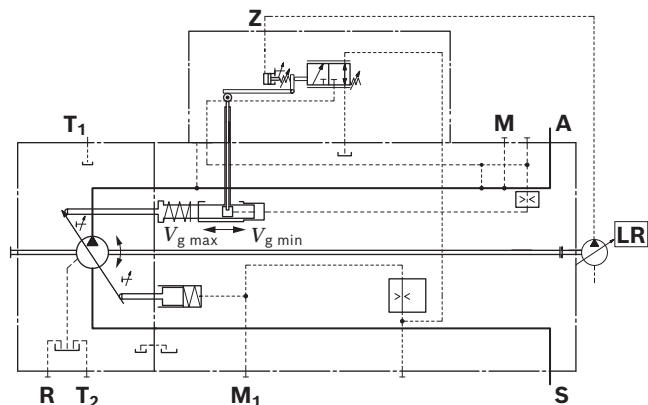

LR3 – High-pressure-dependent override

The high-pressure-dependent power override is a total power control where the working pressure of a mounted fixed pump is applied to the power setting (port Z). Therefore, the A11VO can be set to 100 % of the total drive power. The power setting of the A11VO is reduced proportionally to the load-dependent increase in the working pressure of the fixed pump. The fixed pump has priority in the total power setting. The measuring surface for the power reduction is adapted to the displacement of the fixed pump.

▼ Circuit diagram NG 40 to 145

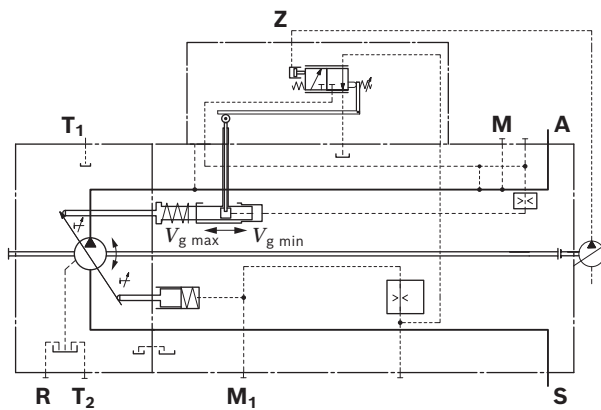

▼ Circuit diagram NG 190 to 260

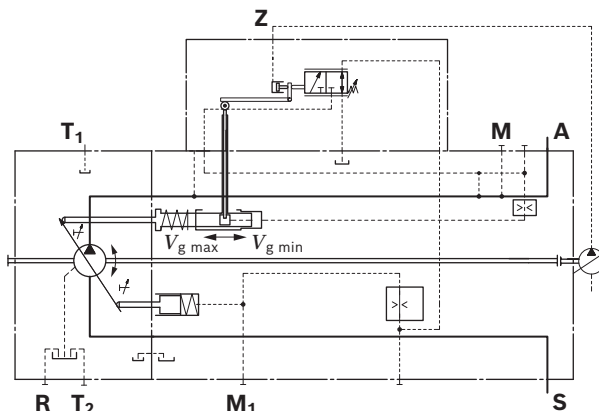

LG1/2 – Pilot-pressure related override

An external pilot pressure acts on the setting spring of the power controller via port **Z**.

The mechanically adjusted basic power setting can be varied by means of different pilot pressure settings. If the pilot pressure signal is adjusted by a load limiting control, the power reduction of all consumers is reduced to match the available power from the diesel engine. The pilot pressure for power influencing is generated by an external control element which is not part of the A11VO (e.g. BODAS LLC – Application software Load limiting control (data sheet 95312)).

LG1 Negative power override

With negative power override LG1, the force resulting from the pilot pressure counteracts the setting spring of the power controller.

Higher pilot pressure = reduced power.

▼ **Circuit diagram NG 40 to 145**

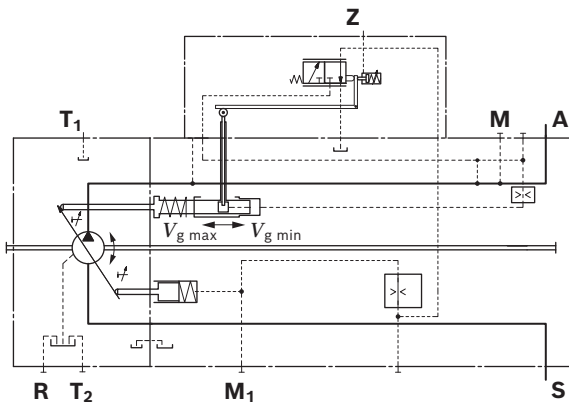

▼ **Circuit diagram NG 190 to 260**

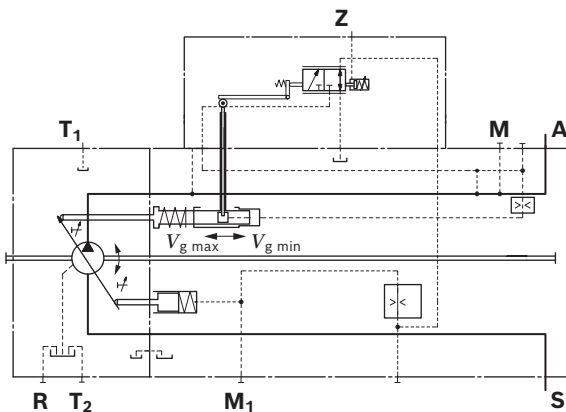

LG2 Positive power override

With positive power override LG2, the force resulting from the pilot pressure supports the setting spring of the power controller.

Higher pilot pressure = increased power.

▼ **Circuit diagram NG 40 to 145**

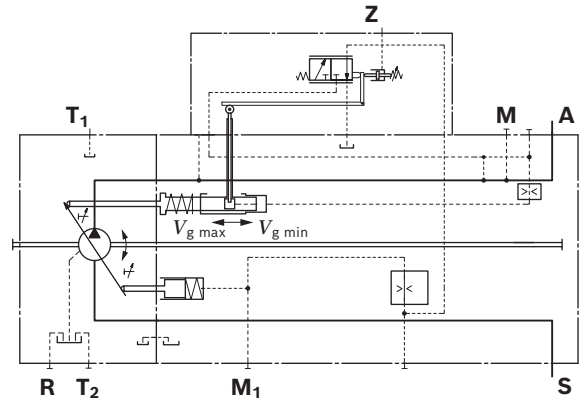

▼ **Circuit diagram NG 190 to 260**

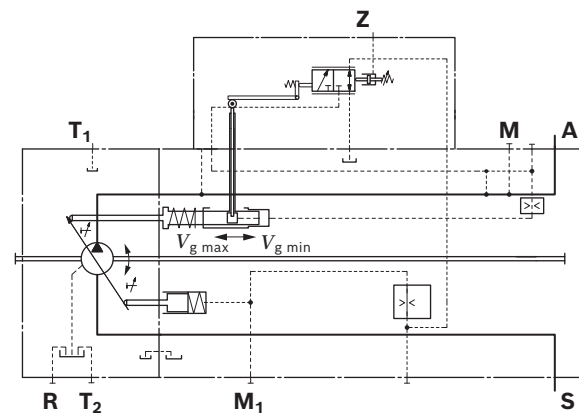

LE2 – Electrically proportional override (negative control)

A control current acts against the adjustment spring of the power controller via a proportional solenoid.

The mechanically adjusted basic power setting can be reduced by means of different control current settings. Increasing control current = reduced power.

If the control current signal is variably controlled via a load limiting control, the power draw of all consumers is adjusted to the power draw possible for the diesel engine (e.g. BODAS LLC – Application software Load limiting control (data sheet 95312) in BODAS controller RC2-2). Direct current of 24 V (LE2) is required to control the proportional solenoid.

Technical data, solenoid	LE2
Voltage	24 V (±20 %)
Control current	
Start of control	200 mA
End of control	600 mA
Current limit	0.77 A
Nominal resistance (at 20 °C)	22.7 Ω
Dither frequency	100 Hz
Duty cycle	100 %
Type of protection: see connector version page 69	

Effect of power override with increasing pressure or current

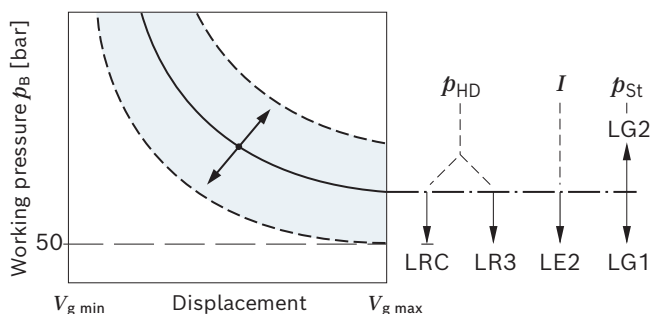

Circuit diagram NG 40 to 145

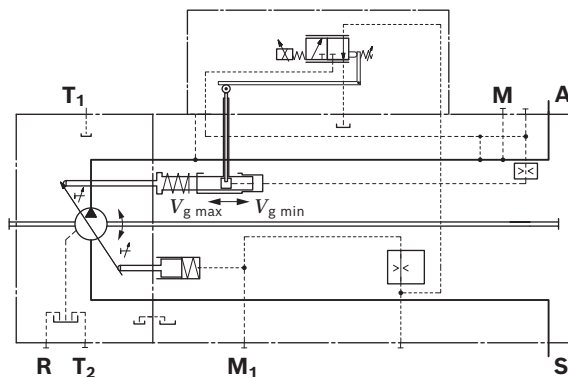

Circuit diagram NG 190 to 260

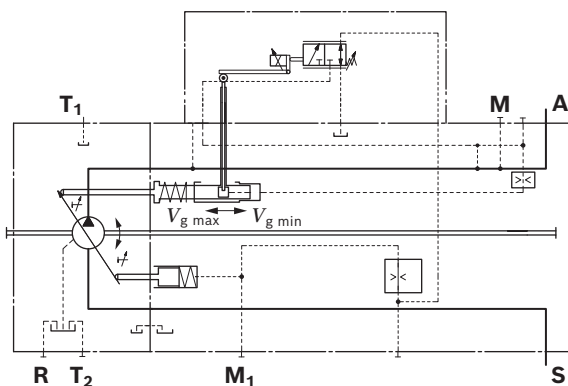

LRD – With pressure cut-off

The pressure cut-off is a pressure control which adjusts the displacement of the pump back to $V_{g \text{ min}}$ after reaching the set pressure command value.

This function overrides the power controller, i.e. the power control function is executed below the pressure command value.

The valve for pressure cut-off is integrated in the controller housing and is permanently set to a pressure command value at the factory.

Setting range from 50 to 350 bar.

▼ **Characteristic curve**

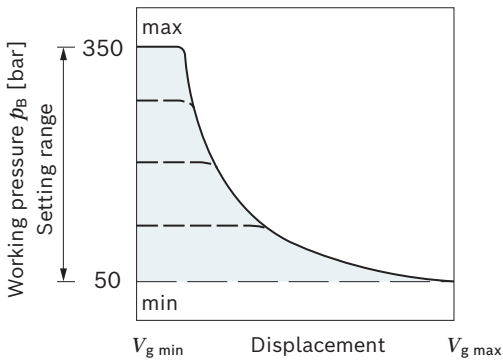

▼ **Circuit diagram NG 40 to 145**

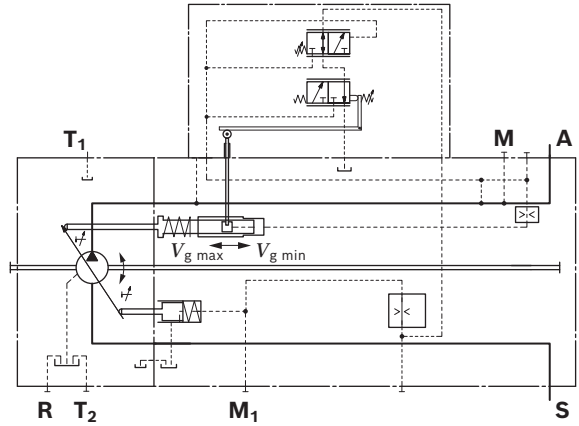

▼ **Circuit diagram NG 190 to 260**

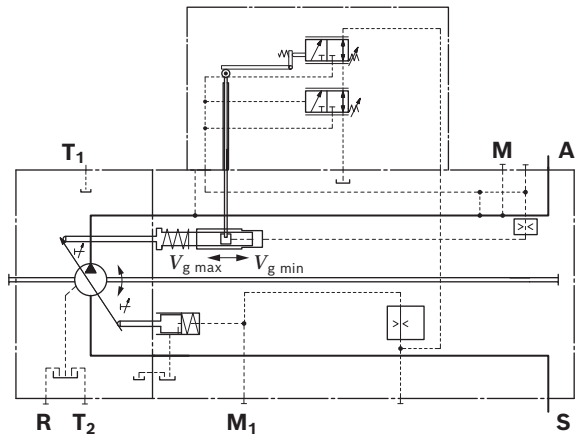

LRDS – With pressure cut-off and load sensing

The load sensing controller works as a load-pressure controlled flow controller and adjusts the displacement of the pump to the volume required by the consumer.

The flow of the pump is then dependent on the cross section of the external metering orifice (1), which is located between the pump and the consumer. Below the power curve and the setting of the pressure cut-off and within the control range of the pump, the flow is independent of the load pressure.

The metering orifice is usually a separately located load sensing directional valve (control block).

The position of the directional valve spool determines the opening cross-section of the metering orifice and thus the flow of the pump.

The load sensing controller compares pressure before and after the metering orifice and keeps the pressure drop (differential pressure Δp) across the orifice and therefore the flow constant.

If the differential pressure Δp at the metering orifice increases, the pump is swiveled back (towards $V_{g \min}$), if the differential pressure Δp decreases the pump is swiveled out (towards $V_{g \max}$), until equilibrium in the valve is restored.

$$\Delta p_{\text{metering orifice}} = p_{\text{pump}} - p_{\text{consumer}}$$

The setting range for Δp is between 14 bar and 25 bar.

The default setting is 18 bar (please specify in plain text).

The stand-by pressure in zero-stroke operation

(metering orifice plugged) is slightly above the Δp setting.

In a standard LS system, the pressure cut-off is integrated in the pump controller. In an LUDV system, the pressure cut-off is integrated in the LUDV valve block.

The metering orifice 1 (control block) is not included in the scope of delivery.

▼ Circuit diagram NG 40 to 145

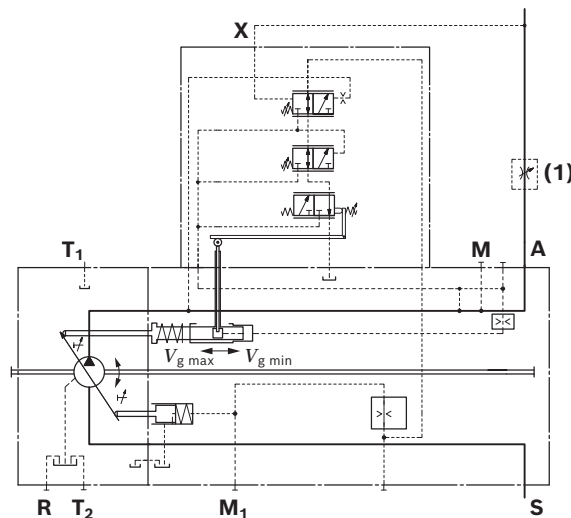

▼ Circuit diagram NG 190 to 260

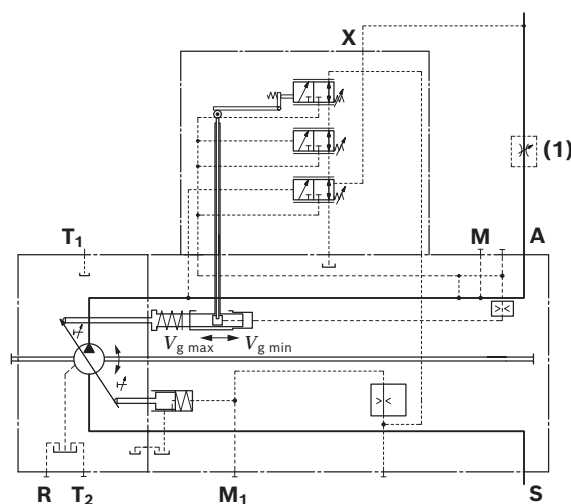

▼ Characteristic curve

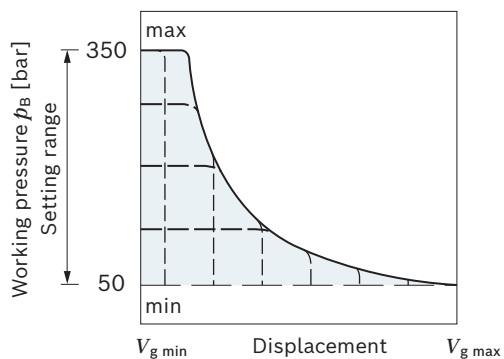

LRS2 – With load sensing, electrically overridable

By connecting a control current on a proportional solenoid, the differential pressure Δp of the load sensing control can be overridden proportionally.

Increasing current = lower Δp setting.

An example of this is shown in the characteristic curve below. Please consult us before carrying out project planning.

For technical data of solenoid, see page 14 (LE2)

▼ **Characteristic curve**

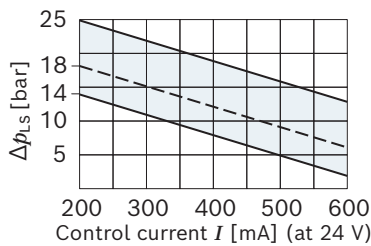

▼ **Circuit diagram NG 40 to 145**

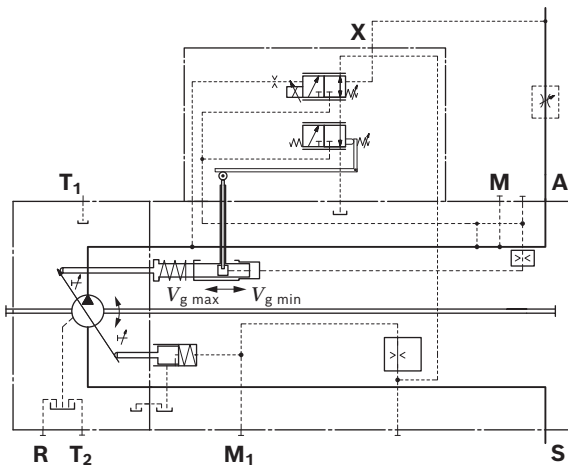

▼ **Circuit diagram NG 190 to 260**

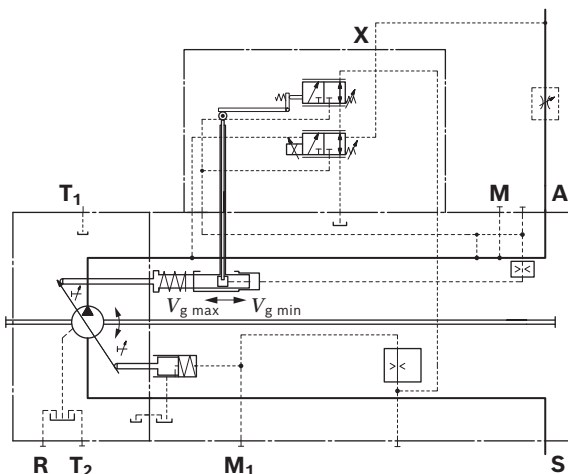

LRS5 – With load sensing, hydraulically overridable

By connecting an external pilot pressure to port Z, the differential pressure Δp of the load sensing control can be overridden proportionally.

Increasing pilot pressure = lower Δp setting.

An example of this is shown in the characteristic curve below. Please consult us before carrying out project planning.

▼ **Characteristic curve**

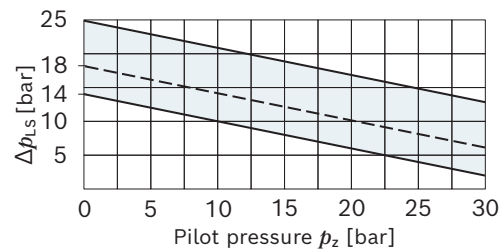

▼ **Circuit diagram NG 40 to 145**

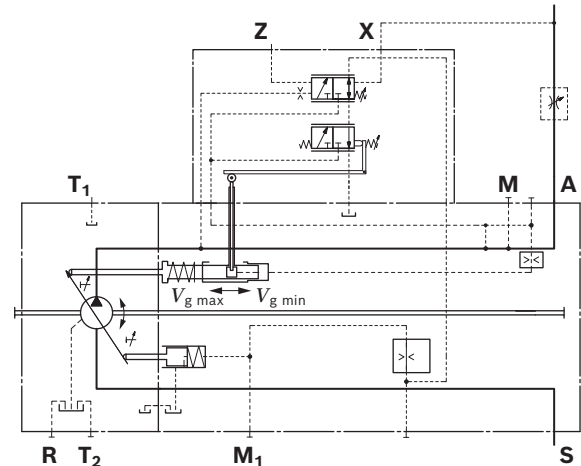

▼ **Circuit diagram NG 190 to 260**

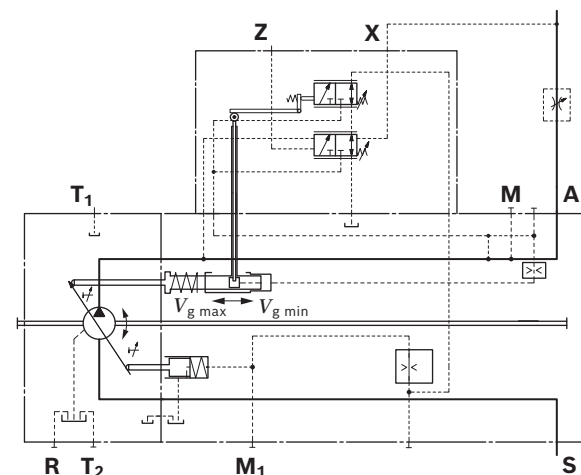

LR... – with stroke limiter

Due to the stroke limiter, it is possible to change or limit the displacement of the pump continuously across the entire control range. At the LRH, the displacement is adjusted proportionally to the pilot pressure p_{st} (max. 40 bar) applied at port **Y** or, at LRU, by the control current applied at the proportional solenoid. Direct current of 24 V (U2, U6) is required to control the proportional solenoid.

The stroke limiter is overridden by the power controller, i.e. below the power controller characteristic curve (hyperbolic characteristic curve) the displacement volume is adjusted depending on the control current or pilot pressure. If the set flow or working pressure exceeds the power control characteristic, the power control overrides and reduces the displacement along the hyperbolic characteristic.

With electric stroke limiter LRU2, LRU6 and hydraulic stroke limiter LRH2, a control pressure of 30 bar is needed to swivel the pump from its initial position $V_{g \max}$ to $V_{g \min}$.

The required control power is taken from the working pressure or the external control pressure applied to port **G**.

To ensure that the stroke limiter functions at a low working pressure of < 30 bar, port **G** must be supplied with an external control pressure of about 30 bar.

Notice

- ▶ If no external control pressure is connected to **G**, the shuttle valve must be removed or relieved to the reservoir.
- ▶ The proportional solenoids in the U6 version have manual override and spring return.

LRH1 – Hydraulic stroke control (negative control)

With pilot-pressure related control, the pump displacement is adjusted proportionally and continuously with a pilot pressure applied at port **Y**.

Basic position without pilot signal is $V_{g \max}$.

- ▶ Control from $V_{g \max}$ to $V_{g \min}$
With increasing pilot pressure the pump swivels to a smaller displacement.
- ▶ Setting range for beginning of control (at $V_{g \max}$)
4 to 10 bar State the beginning of control in plain text in the order.

- ▶ Maximum permissible pilot pressure $p_{st \max} = 40$ bar
The required control fluid is taken from the working pressure or the external control pressure applied to port **G**.

In order for the pump to be moved from the basic position zero or at low working pressure, port **G** must be supplied with external control pressure of at least 30 bar, maximum 40 bar.

Notice

If no external control pressure is connected to **G**, this must be indicated in plain text.

In this case, the shuttle valve is not included in the scope of delivery.

Without external control pressure, the stroke control has only limited functionality. Please contact us.

▼ **Characteristic curve H1**

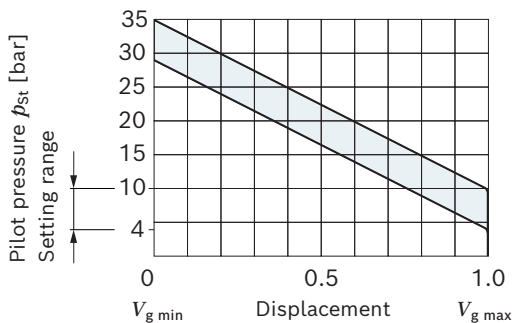

Pilot pressure increase $V_{g \max}$ to $V_{g \min}$: $\Delta p = 25$ bar

▼ **Circuit diagram NG 40 to 145**

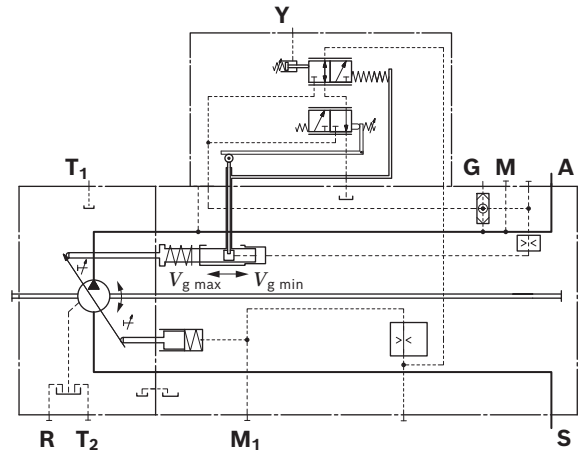

▼ **Circuit diagram NG 190 to 260**

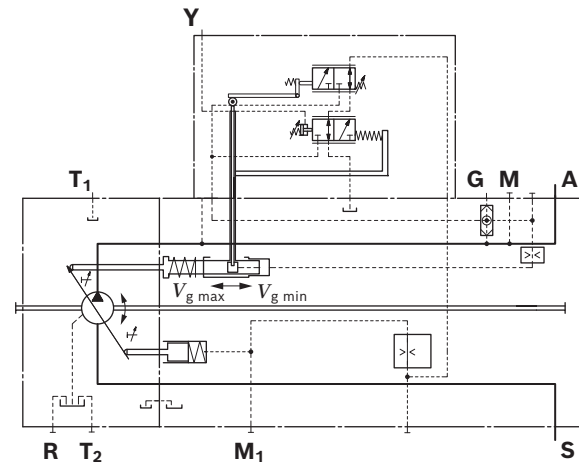

LRH2 – Hydraulic stroke control (positive control)

With pilot-pressure related control, the pump displacement is adjusted proportionally and continuously with a pilot pressure applied at port **Y**.
Start of adjustment without pilot signal is $V_{g \min}$ (at working pressure or external control pressure >30 bar).

- ▶ Control from $V_{g \min}$ to $V_{g \max}$
With increasing pilot pressure the pump swivels to a higher displacement.
- ▶ Setting range for beginning of control (at $V_{g \min}$)
4 to 10 bar State the beginning of control in plain text in the order.
- ▶ Maximum permissible pilot pressure $p_{St \max} = 40$ bar
The required control fluid is taken from the working pressure or the external control pressure applied to port **G**. In order for the pump to be moved from the basic position zero or at low working pressure, port **G** must be supplied with external control pressure of at least 30 bar, maximum 40 bar.

Notice

- ▶ If no external control pressure is connected to **G**, this must be indicated in plain text.
In this case, the shuttle valve is not included in the scope of delivery.
- ▶ Without external control pressure, the stroke control has only limited functionality. Please contact us.

▼ Characteristic curve H2

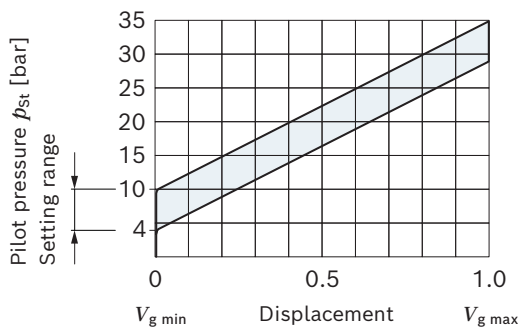

Pilot pressure increase $V_{g \min}$ to $V_{g \max}$: $\Delta p = 25$ bar

▼ Circuit diagram NG 40 to 145

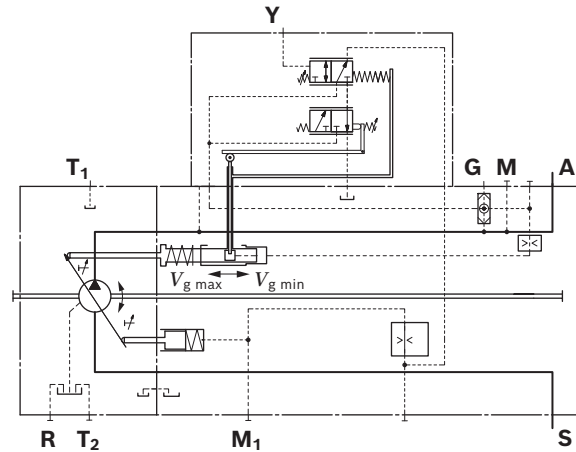

▼ Circuit diagram NG 190 to 260

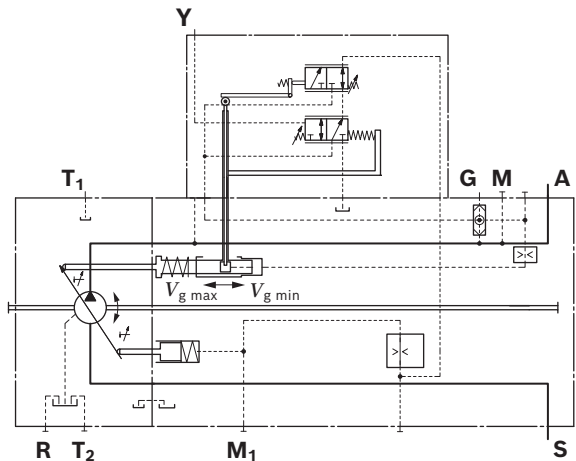

LRU2/LRU6 – Electric stroke control (positive control)

With the electrical stroke control with proportional solenoid, the pump displacement is steplessly adjusted in proportion to the current via the magnetic force. Beginning of control without pilot signal is $V_{g \min}$ (at working or external control pressure > 30 bar). The mechanically depressurized basic position is $V_{g \max}$. With increasing control current the pump swivels to a greater displacement (from $V_{g \min}$ to $V_{g \max}$). The required control fluid is taken from the working pressure or the external control pressure applied to port **G**. In order for the pump to be moved from the basic position zero or at low working pressure, port **G** must be supplied with external control pressure of at least 30 bar, maximum 40 bar.

Notice

- ▶ If no external control pressure is connected to **G**, this must be indicated in plain text. In this case, the shuttle valve is not included in the scope of delivery.
- ▶ Without external control pressure, the stroke control has only limited functionality. Please contact us.

▼ **Characteristic curve**

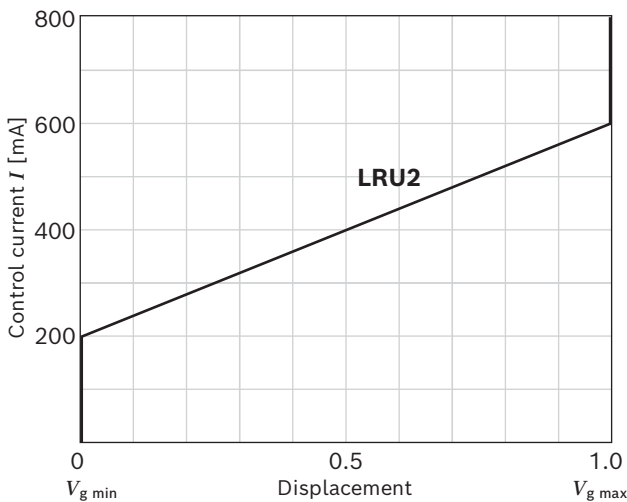

Technical data, solenoid	LRU2/LRU6
Voltage	24 V ($\pm 20\%$)
Control current	
Beginning of control at $V_{g \min}$	200 mA
End of control at $V_{g \max}$	600 mA
Current limit	0.77 A
Nominal resistance (at 20 °C)	22.7 Ω
Dither frequency	100 Hz
Duty cycle	100 %
Type of protection: see connector version page 69	

A wide range of BODAS controllers with application software and analog amplifiers are available to control the proportional solenoids.

Further information can also be found online under www.boschrexroth.com/mobile-electronics.

▼ **Circuit diagram NG 40 to 145**

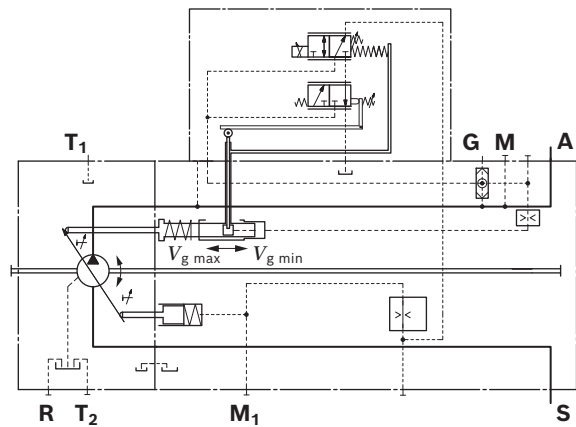

▼ **Circuit diagram NG 190 to 260**

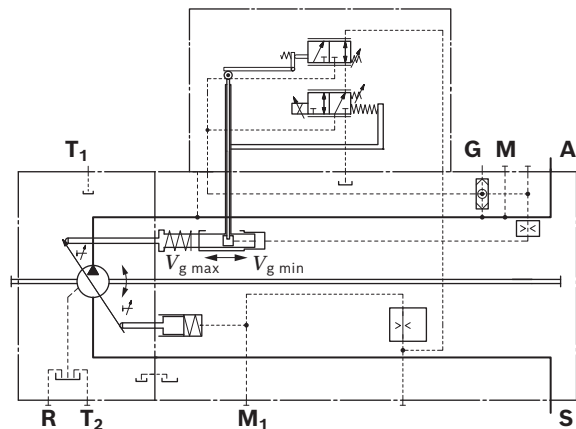

Pressure controller

DR – Pressure controller

The pressure controller limits the maximum pressure at the pump outlet within the control range of the variable pump. The variable pump only supplies as much hydraulic fluid as is required by the consumers.

If the working pressure exceeds the pressure command value at the pressure valve, the pump will regulate to a smaller displacement to reduce the control differential.

- ▶ Basic position in depressurized state: $V_{g \max}$
- ▶ Setting range for pressure control: 50 to 350 bar.
Specify pressure controller setting in plain text when ordering.

▼ Characteristic curve

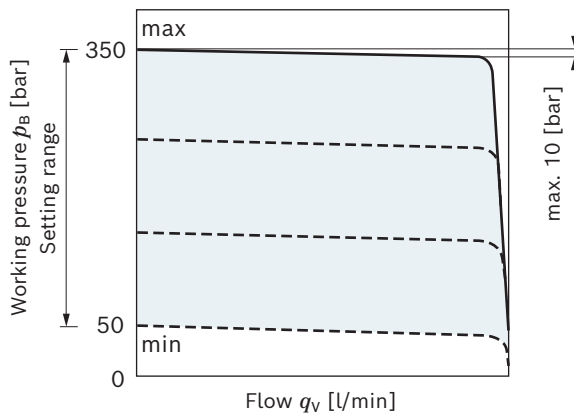

▼ Circuit diagram NG 40 to 145

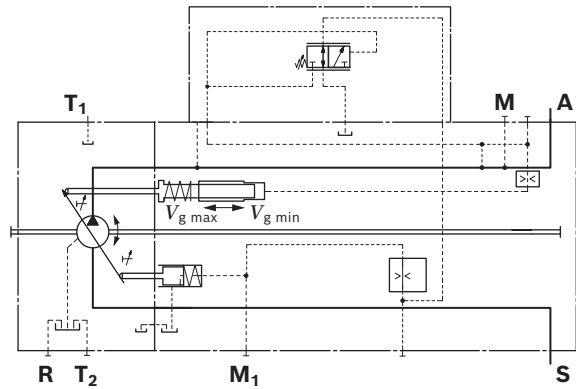

▼ Circuit diagram NG 190 to 260

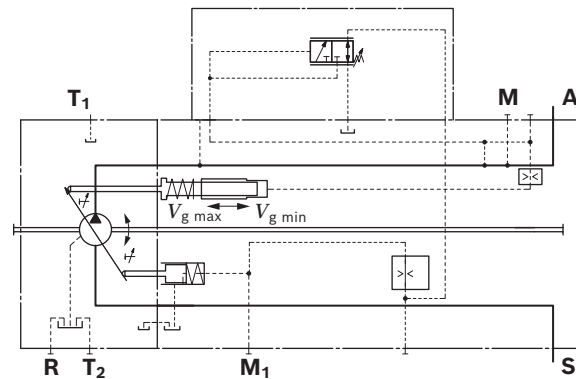

DRS – Pressure controller with load sensing

The load sensing controller works as a load-pressure controlled flow controller and adjusts the displacement of the pump to the volume required by the consumer. The flow of the pump is then dependent on the cross section of the external metering orifice (1), which is located between the pump and the consumer. Below the setting of the pressure controller and within the control range of the pump, the flow is not dependent on the load pressure.

The metering orifice is usually a separately located load sensing directional valve (control block).

The position of the directional valve spool determines the opening cross-section of the metering orifice and thus the flow of the pump.

The load sensing controller compares the pressure upstream the metering orifice to the one downstream the orifice and keeps the pressure drop (differential pressure Δp) occurring here and thus the flow constant.

If the differential pressure Δp at the metering orifice rises, the pump is swiveled back (toward $V_{g \text{ min}}$). If the differential pressure Δp drops, the pump is swiveled out (toward $V_{g \text{ max}}$) until equilibrium at the metering orifice is restored.

$$\Delta p_{\text{metering orifice}} = p_{\text{pump}} - p_{\text{consumer}}$$

- ▶ Setting range for Δp 14 to 25 bar (please state in plain text)
- ▶ Standard setting 18 bar

The stand-by pressure in zero-stroke operation (metering orifice closed) is slightly higher than the Δp setting.

The metering orifice 1 (control block) is not included in the scope of delivery.

▼ **Characteristic curve**

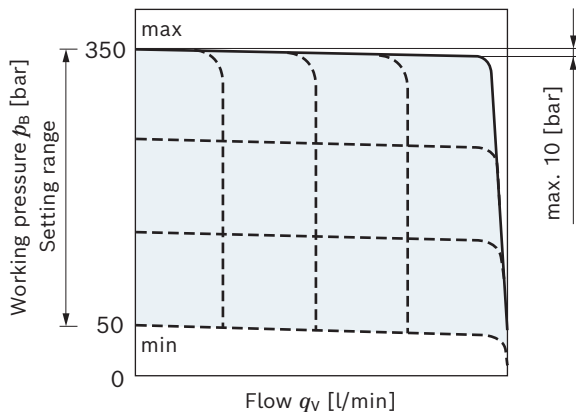

▼ **Circuit diagram NG 40 to 145**

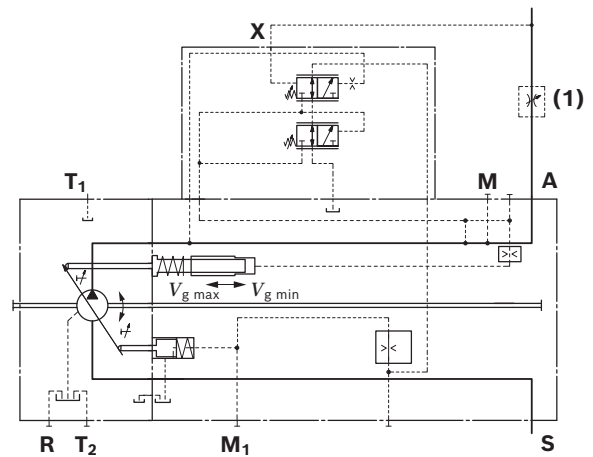

▼ **Circuit diagram NG 190 to 260**

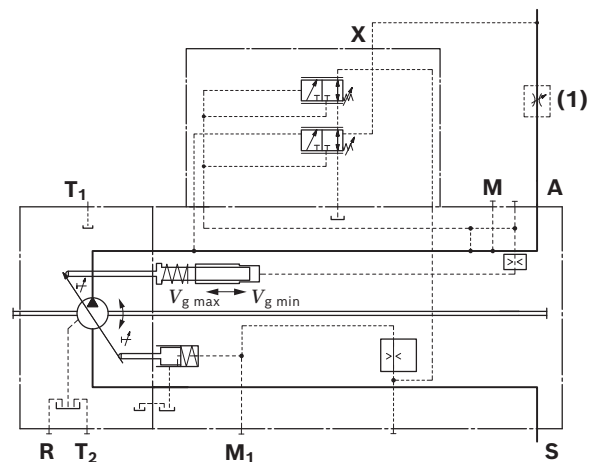

DRG – Pressure controller, hydraulically remote-controlled

On the remote-controlled pressure controller, the setting of the pressure controller can be overridden by a separate pressure relief valve (1) to set a lower pressure command value.

Setting range from 50 to 350 bar.

In addition a separately configured 2/2 directional valve (2) can be operated to start the pump with low working pressure (standby pressure).

Setting range for Δp 14 to 25 bar, standard setting 22 bar (when ordering, please state in plain text)

Both functions can be used individually or in combination (see circuit diagram).

The external valves are not included in the scope of delivery.

As a separate pressure relief valve (1) we recommend: DBDH 6 (manual actuation) see data sheet 25402.

▼ **Characteristic curve**

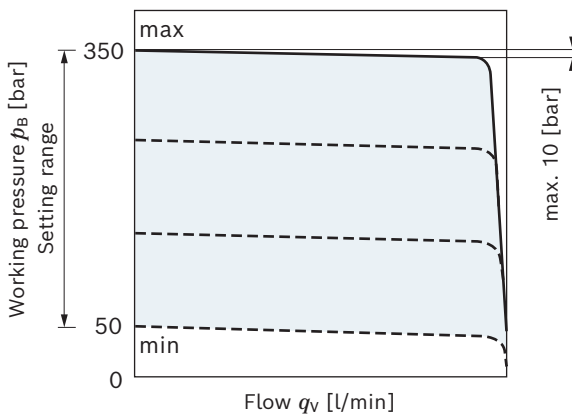

Notice

Remote-controlled pressure cut-off is also possible in connection with LR, HD and EP.

▼ **Circuit diagram NG 40 to 145**

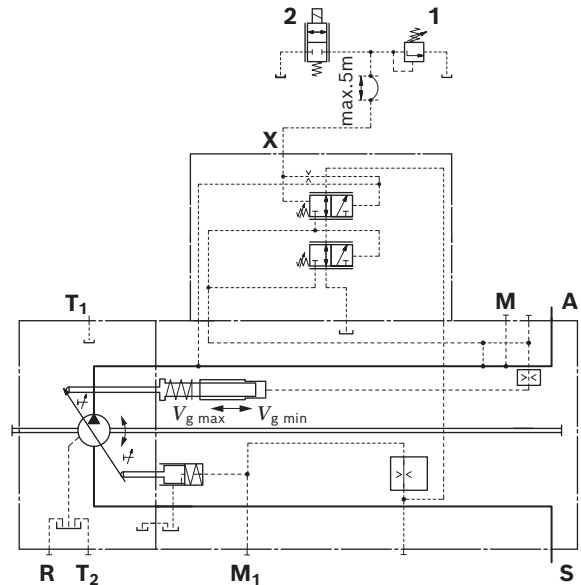

▼ **Circuit diagram NG 190 to 260**

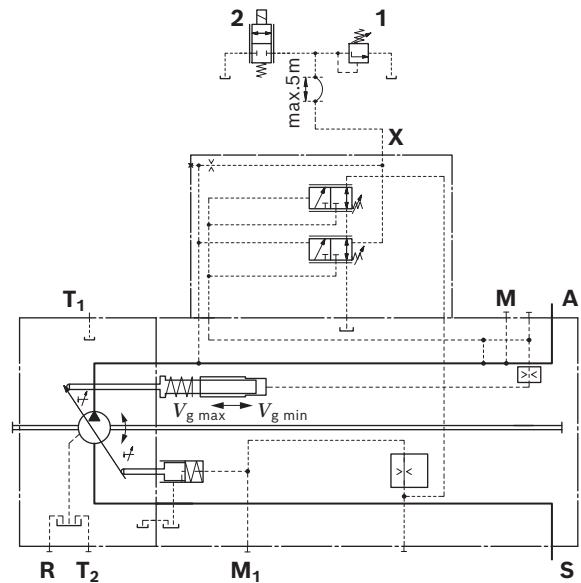

DRL – Pressure controller for parallel operation

The DRL pressure controller is suitable for pressure control of several A11VO axial piston pumps in parallel operation pumping into a common pressure line. The pressure cut-off has a pressure increase of approx. 15 bar from $q_{v \max}$ to $q_{v \min}$. The pump regulates therefore to a pressure dependent swivel angle. This results in a stable controller behavior. With the externally installed pressure relief valve (1) the nominal pressure command value of all pumps connected to the system is adjusted to the same value. Setting range from 50 to 350 bar. Each pump can be individually unloaded from the system by a separately installed 3/2 directional valve (2). The check valves (3) in the working line (port A) or control line (connection X) must be generally provided. The external valves are not included in the scope of delivery. As a separate pressure relief valve (1) we recommend: DBDH 6 (manual actuation) see data sheet 25402.

▼ **Circuit diagram NG 40 to 260**

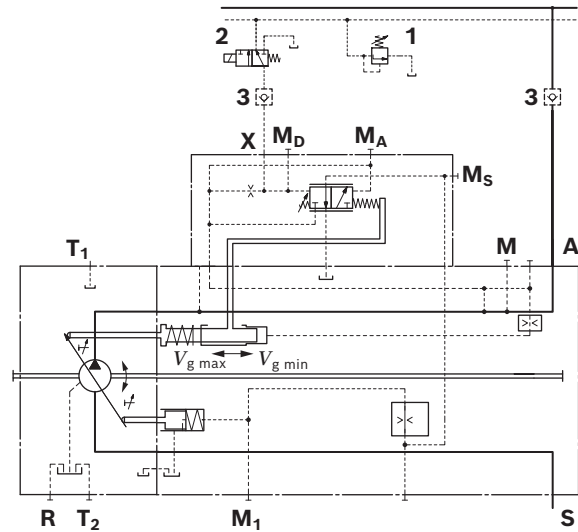

▼ **Characteristic curve**

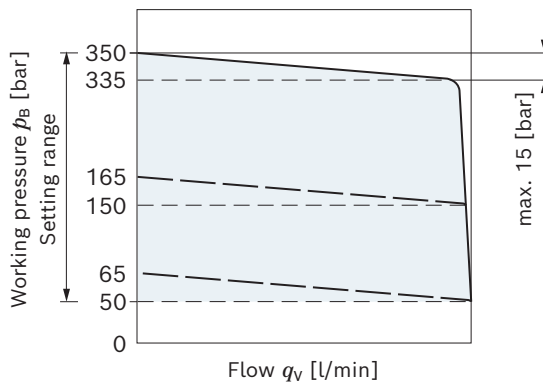

Hydraulic control, pilot-pressure related

HD2 – Hydraulic control

With pilot-pressure related control, the pump displacement is adjusted proportionally and continuously with a pilot pressure applied at port **Y**.

Start of adjustment without pilot signal is $V_{g \min}$ (at working pressure or external control pressure >30 bar).

- ▶ Control from $V_{g \min}$ to $V_{g \max}$
With increasing pilot pressure the pump swivels to a higher displacement.
- ▶ Setting range for beginning of control (at $V_{g \min}$)
4 to 10 bar State the beginning of control in plain text in the order.
- ▶ Maximum permissible pilot pressure $p_{st \max} = 40$ bar
The required control fluid is taken from the working pressure or the external control pressure applied to port **G**. In order for the pump to be moved from the basic position zero or at low working pressure, port **G** must be supplied with external control pressure of at least 30 bar, maximum 40 bar.

▼ Circuit diagram NG 40 to 260

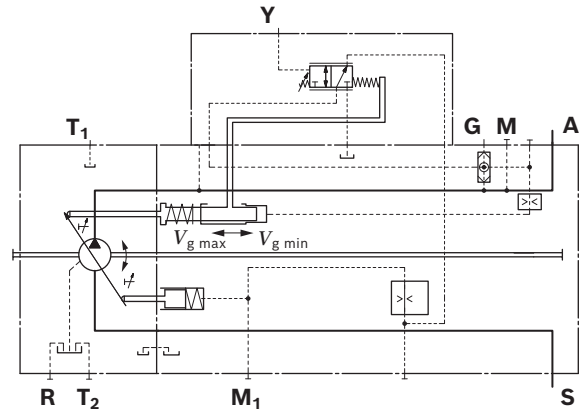

Notice

- ▶ If no external control pressure is connected to **G**, this must be indicated in plain text.
In this case, the shuttle valve is not included in the scope of delivery.
- ▶ Without external control pressure, the stroke control by $V_{g \min}$ has only limited functionality. Please contact us.

▼ HD2 characteristic curve

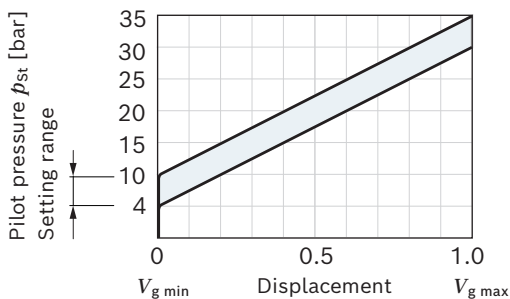

Pilot pressure increase $V_{g \min}$ to $V_{g \max}$: $\Delta p = 25$ bar

HD2D – Hydraulic control with pressure cut-off

The pressure cut-off is a pressure control which adjusts the displacement of the pump back to $V_{g \text{ min}}$ after reaching the set pressure command value.

This function overrides the hydraulic stroke control, i.e. the stroke control function is executed below the pressure command value.

The valve for pressure cut-off is integrated in the controller housing and is permanently set to a pressure command value at the factory.

Setting range from 50 to 350 bar.

▼ **Characteristic curve**

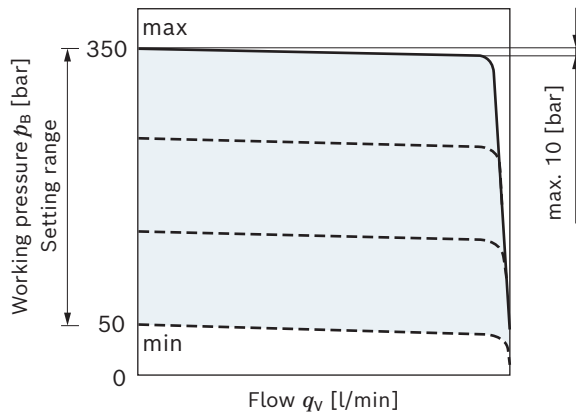

▼ **Circuit diagram NG 40 to 145**

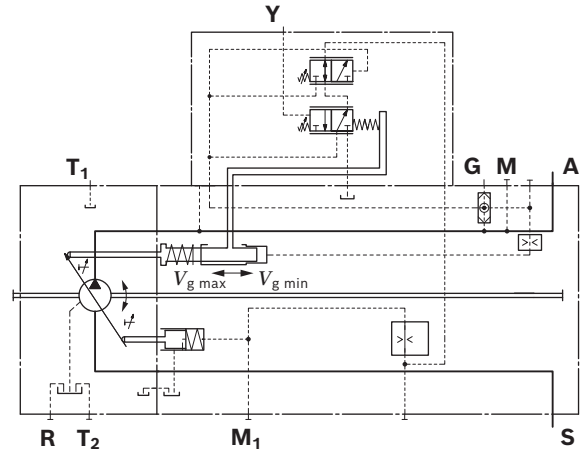

▼ **Circuit diagram NG 190 to 260**

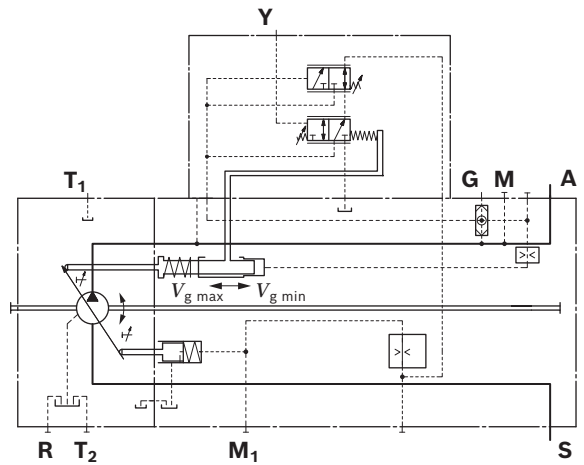

Electrical control with proportional solenoid

EP2/EP6 – Electric control

With the electrical control with proportional solenoid, the pump displacement is steplessly adjusted in proportion to the current via the magnetic force.

Beginning of control without pilot signal is $V_{g \min}$ (at working or external control pressure > 30 bar).

Control from $V_{g \min}$ to $V_{g \max}$

With increasing control current the pump swivels to a higher displacement.

The required control fluid is taken from the working pressure or the external control pressure applied to port **G**. In order for the pump to be moved from the basic position zero or at low working pressure, port **G** must be supplied with external control pressure¹⁾ of at least 30 bar, maximum 40 bar.

Notice

- ▶ If no external control pressure is connected to **G**, this must be indicated in plain text. In this case, the shuttle valve is not included in the scope of delivery.
- ▶ Without external control pressure, the stroke control has only limited functionality. Please contact us
- ▶ The proportional solenoids in the EP6 version have manual override and spring return.

▼ Characteristic curve

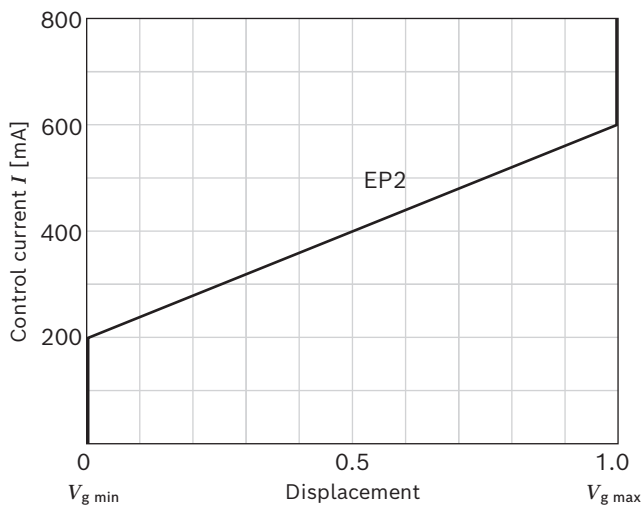

¹⁾ With an external control pressure supply, it is possible for the pump to swivel slightly beyond the zero position (to the mechanical stop).

Technical data, proportional solenoid	EP2/EP6
Voltage	24 V ($\pm 20\%$)
Control current	
Beginning of control at $V_{g \min}$	200 mA
End of control at $V_{g \max}$	600 mA
Current limit	0.77 A
Nominal resistance (at 20 °C)	22.7 Ω
Dither frequency	100 Hz
Duty cycle	100 %
Type of protection: see connector version page 69	

A wide range of BODAS controllers with application software and analog amplifiers are available to control the proportional solenoids.

Further information can also be found online under www.boschrexroth.com/mobile-electronics.

▼ Circuit diagram NG 40 to 260

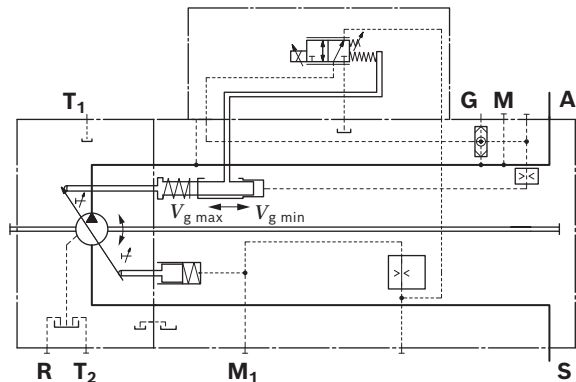

EP2D/EP6D – Electric control with pressure cut-off

The pressure cut-off is a pressure control which adjusts the displacement of the pump back to $V_{g \text{ min}}$ after reaching the set pressure command value.

This function overrides the electric control, i.e. the control-current-dependent function is executed below the pressure command value.

The valve for pressure cut-off is integrated in the controller housing and is permanently set to a pressure command value at the factory.

Setting range from 50 to 350 bar.

▼ **Characteristic curve**

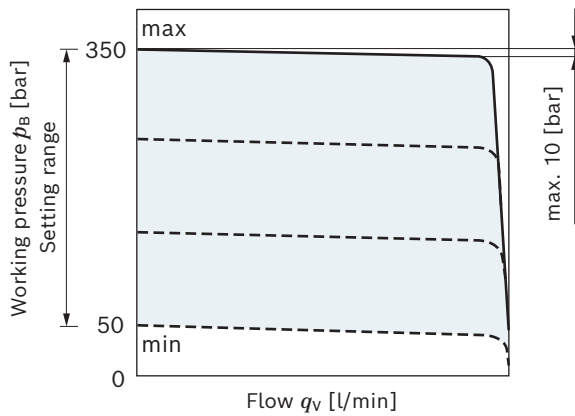

▼ **Circuit diagram NG 40 to 145**

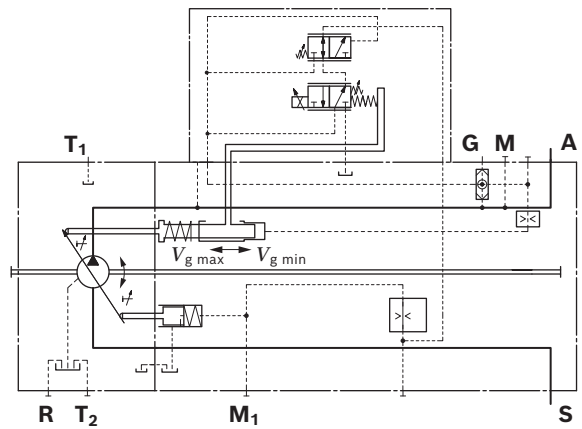

▼ **Circuit diagram NG 190 to 260**

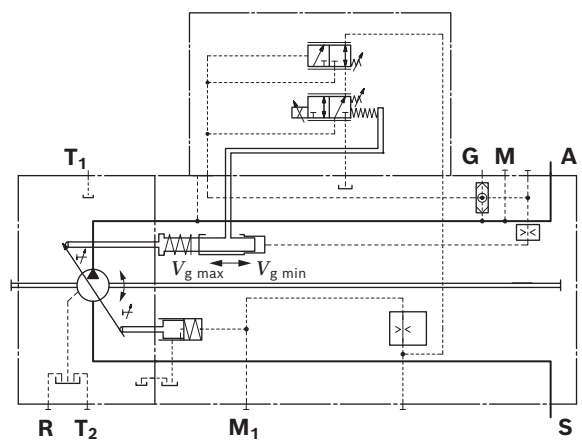

EP2G2 – Electric control with electrically overridable pressure cut-off (negative control)

The remote-controlled G2 pressure controller has a fixed Δp value. An electric pressure relief valve (pilot valve) integrated in the controller enables remote pressure control.

- ▶ Recommendation for fixed set value at Δp 22 bar.

When ordering, state in plain text:

- ▶ Maximum pressure p_{max} [bar] (pressure on port **A**) with 0 mA current.

Pilot valve G2

The electro proportional pressure relief valve is directly controlled with negative control as cartridge version (see KBPS.8B data sheet 18139-05).

▼ **Characteristic curve G2**

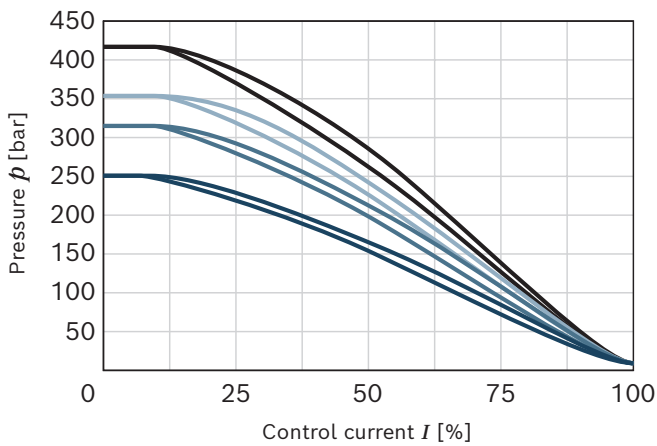

Technical data, proportional solenoid	G2
Voltage	24 V
Control current	
Minimum pressure p_{min}	1200 mA
Maximum pressure p_{max}	0 mA
Maximum rated current	1200 mA
Nominal resistance (at 20 °C)	4.8 Ω
Dither frequency	200 Hz
Duty cycle	100 %
Type of protection: see connector version page 69	

A wide range of BODAS controllers with application software and analog amplifiers are available to control the proportional solenoids.

Further information can also be found online under www.boschrexroth.com/mobile-electronics.

▼ **Circuit diagram NG 95 to 260**

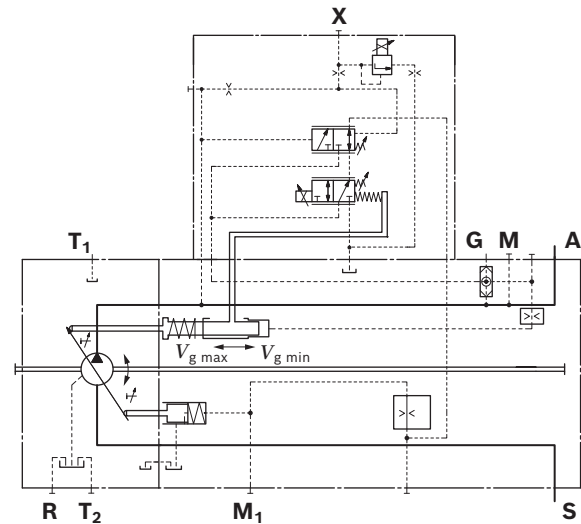

EP2G4 – Electric control with electrically overridable pressure cut-off (positive control)

The remote-controlled G4 pressure controller has a fixed Δp value. An electric pressure relief valve (pilot valve) integrated in the controller enables remote pressure control.

- ▶ Recommendation for fixed set value at Δp 22 bar.

When ordering, state in plain text:

- ▶ Maximum pressure p_{max} [bar] (pressure on port **A**) with maximum current.

Pilot valve G4

The electro proportional pressure relief valve is directly controlled with positive control as cartridge version (see KBPS.8A data sheet 18139-04).

▼ **Characteristic curve G4**

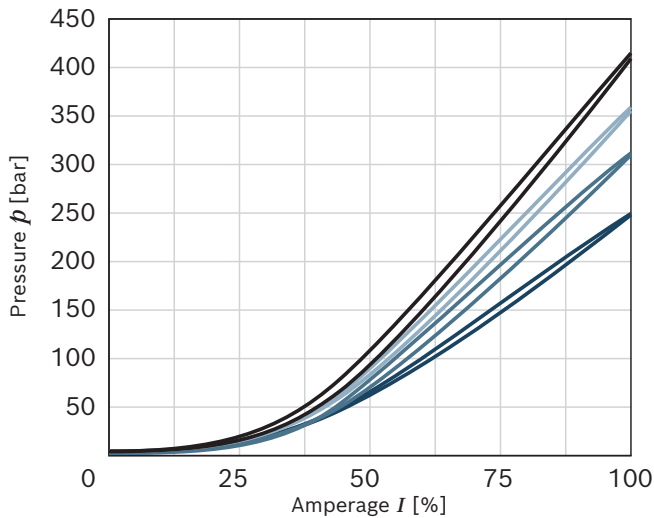

A wide range of BODAS controllers with application software and analog amplifiers are available to control the proportional solenoids.

Further information can also be found online under www.boschrexroth.com/mobile-electronics.

▼ **Circuit diagram NG 95 to 260**

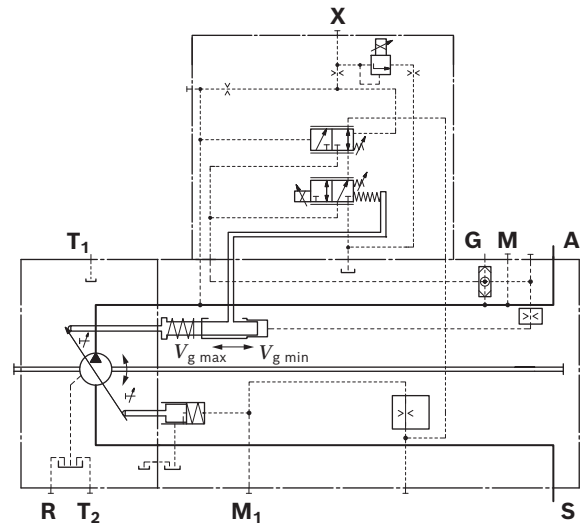

Technical data, proportional solenoid	G4
Voltage	24 V
Control current	
Minimum pressure p_{min}	0 mA
Maximum pressure p_{max}	1200 mA
Maximum rated current	1200 mA
Nominal resistance (at 20 °C)	4.8 Ω
Dither frequency	200 Hz
Duty cycle	100 %
Type of protection: see connector version	page 69

Dimensions, size 40

LRDCS – Power controller with pressure cut-off, cross-sensing and load sensing

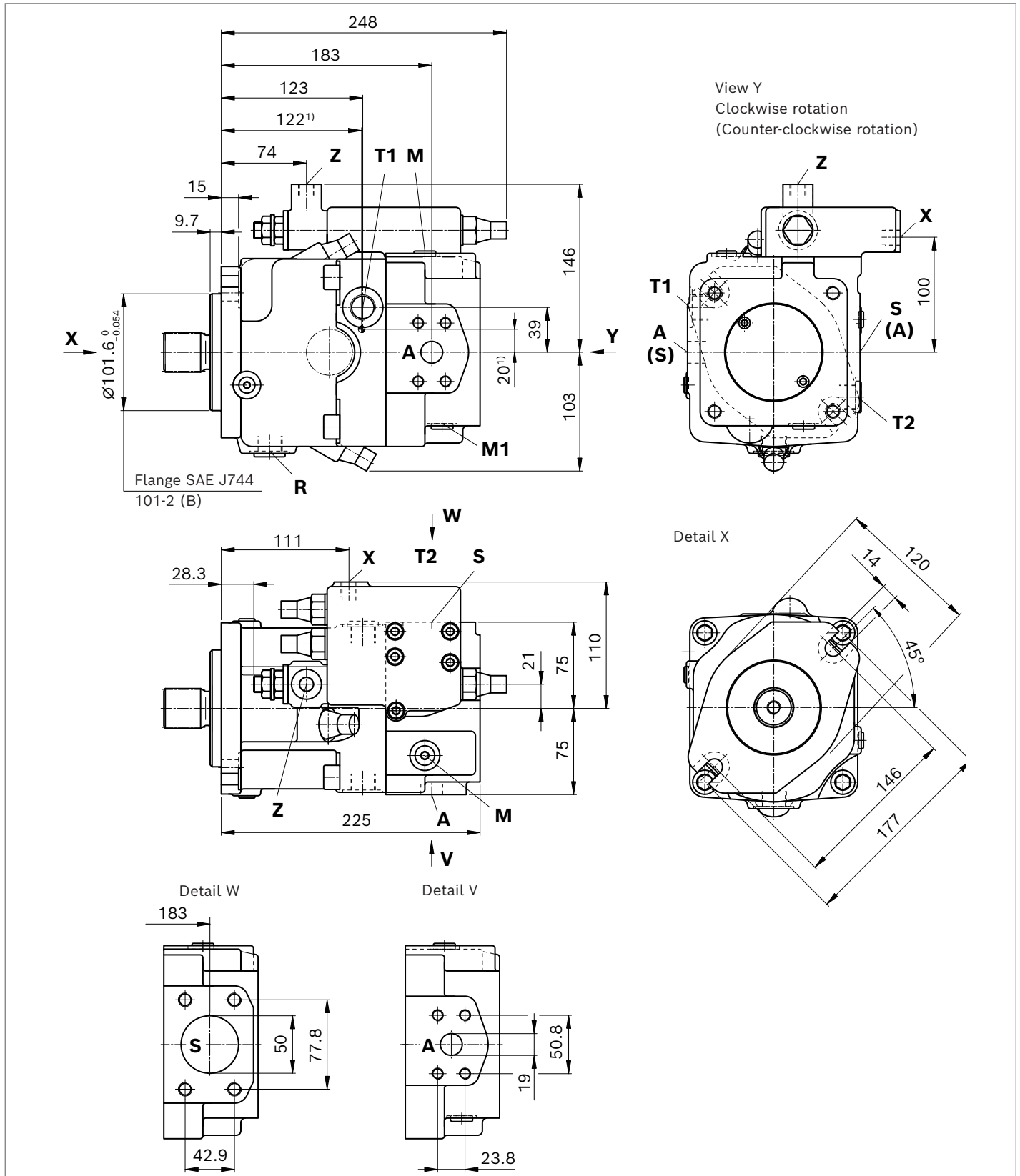

1) Center of gravity.

▼ **Splined shaft DIN 5480**

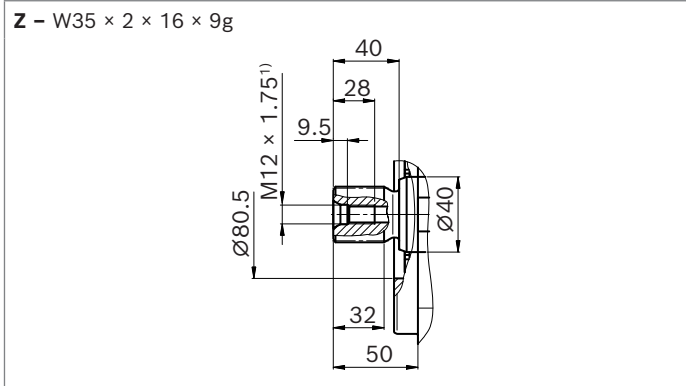

▼ **Parallel keyed shaft DIN 6885**

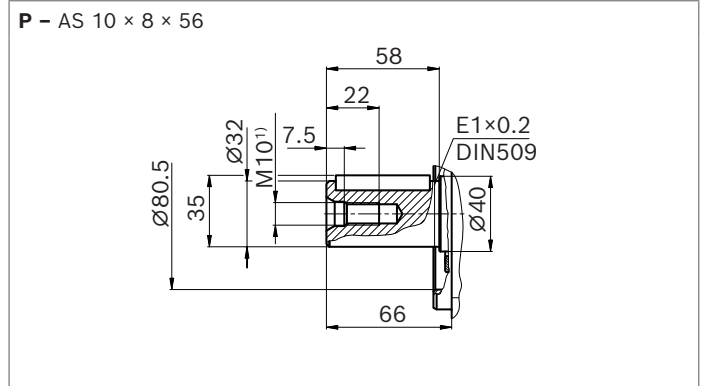

▼ **Splined shaft SAE J744**

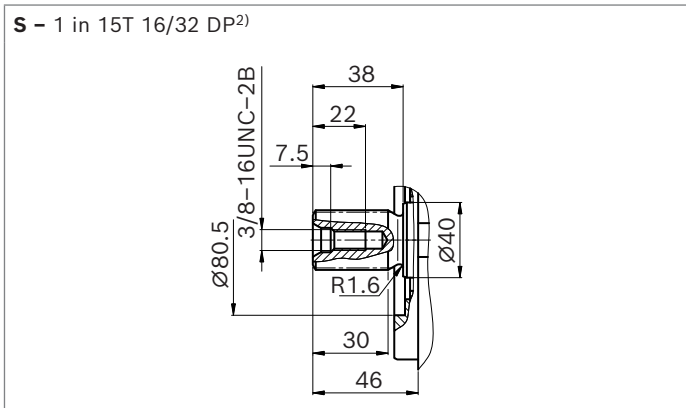

▼ **Splined shaft SAE J744**

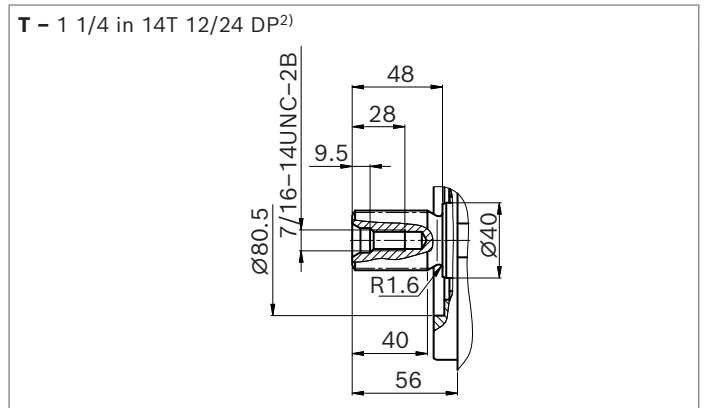

Ports		Standard	Size	p_{max} [bar] ³⁾	State ⁵⁾
A	Working port Fastening thread	SAE J518 DIN 13	3/4 in M10 × 1.5; 16 deep	400	O
S	Suction port (without charge pump) Fastening thread	SAE J518 DIN 13	2 in M12 × 1.75; 17 deep	30	O
T₁	Drain port	DIN 3852	M22 × 1.5; 14 deep	10	4)
T₂	Drain port	DIN 3852	M22 × 1.5; 14 deep	10	4)
R	Air bleed port	DIN 3852	M22 × 1.5; 14 deep	10	X
M₁	Measuring port control pressure	DIN 3852	M12 × 1.5; 12 deep	400	X
M	Measuring port pressure A	DIN 3852	M12 × 1.5; 12 deep	400	X
X	Pilot pressure port for version with load sensing (S) and remote-controlled pressure cut-off (G)	DIN 3852	M14 × 1.5; 12 deep	400	O
Y	Pilot pressure port for version with stroke limiter (H..) and HD	DIN 3852	M14 × 1.5; 12 deep	40	O
Z	Pilot pressure port for version with cross sensing (C) and power override (LR3) Power override (LG1)	DIN 3852	M14 × 1.5; 12 deep	400 40	O
G	Control pressure port (controller) for version with stroke limiter (H..., U2, U6), HP and EP (otherwise plugged)	DIN 3852	M14 × 1.5; 12 deep	40	O

1) Center bore according to DIN 332 (thread according to DIN 13)
 2) ANSI B92.1a-1976, 30° pressure angle, flat root, side fit, tolerance class 5
 3) Dependent on settings and working pressure

4) Depending on installation position, **T₁** or **T₂** must be connected (see also installation instructions on pages 70 to 73)
 5) O = Must be connected (plugged on delivery)
 X = Plugged (in normal operation)

▼ **LRDH1** – Power controller, pressure cut-off, hydraulic stroke limiter (negative control)

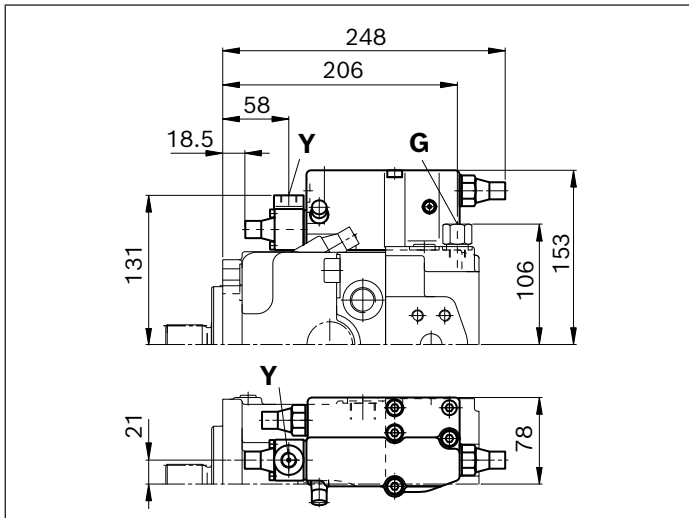

▼ **LRDH2** – Power controller, pressure cut-off, hydraulic stroke limiter (positive control)

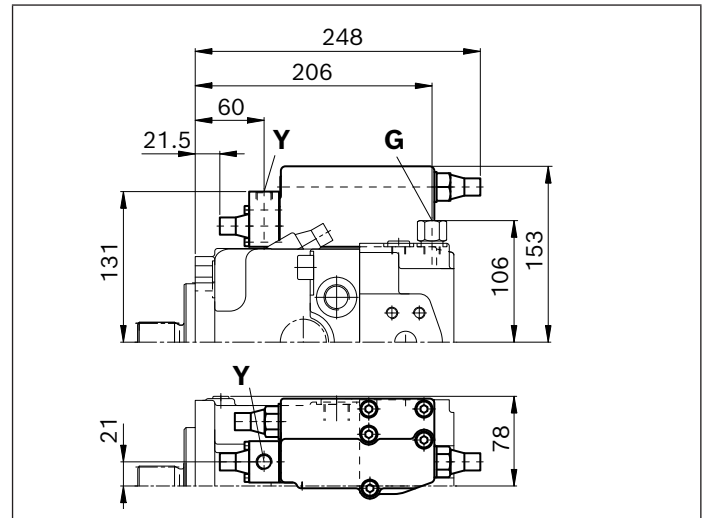

▼ **LRDU2** – Power controller, pressure cut-off, hydraulic stroke limiter (positive control)

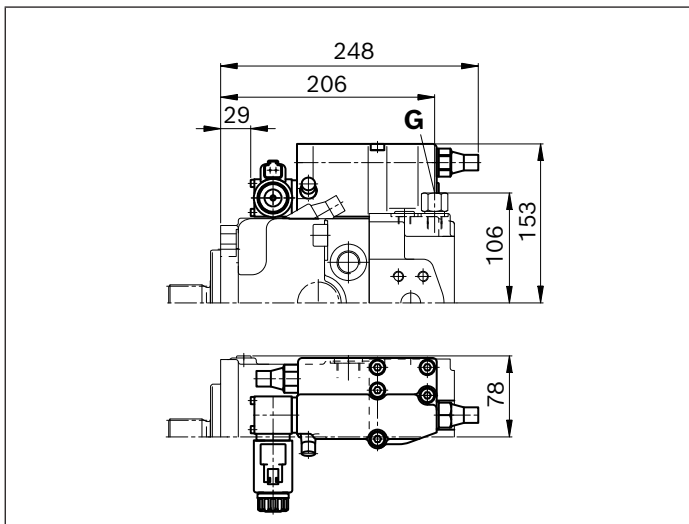

▼ **LR3DS** – Power controller, high-pressure-dependent override, pressure cut-off, load sensing

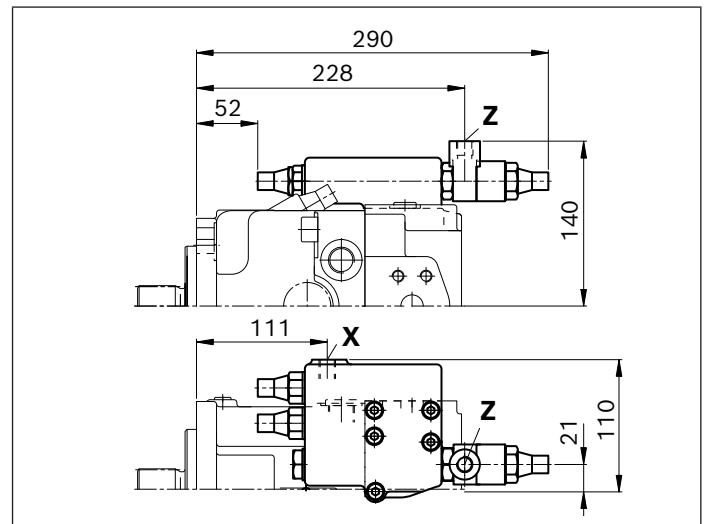

▼ **HD2D** – Hydraulic, pilot-pressure related control, pressure cut-off

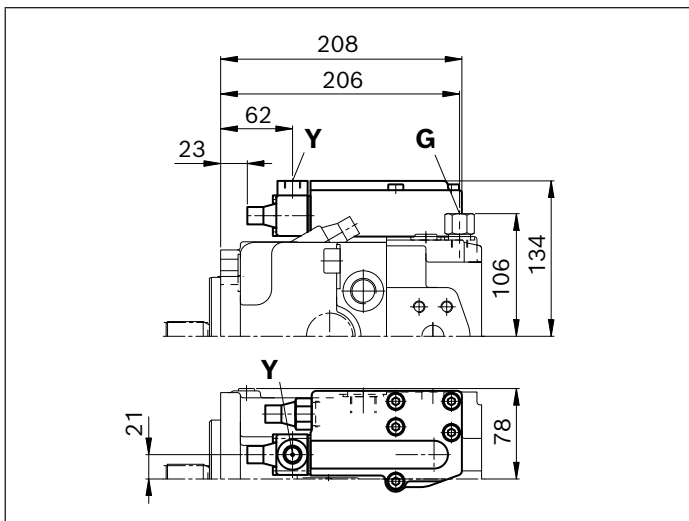

▼ **EP2D** – Electric control, proportional solenoid, pressure cut-off

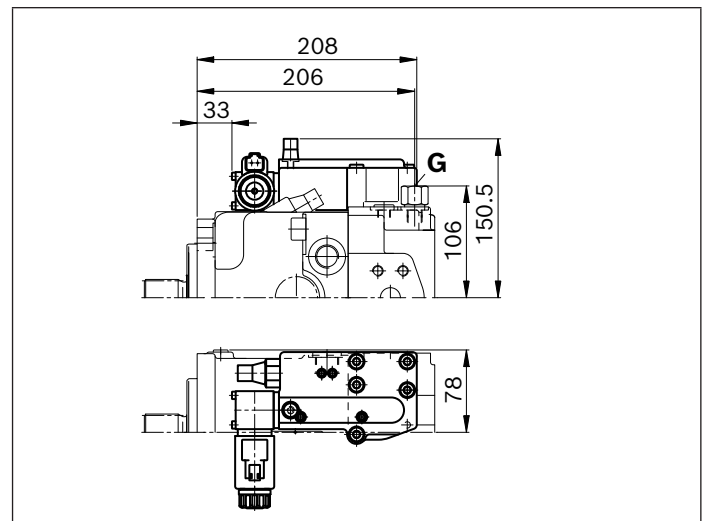

▼ **DRS/DRG – Remote-controlled pressure controller, load sensing**

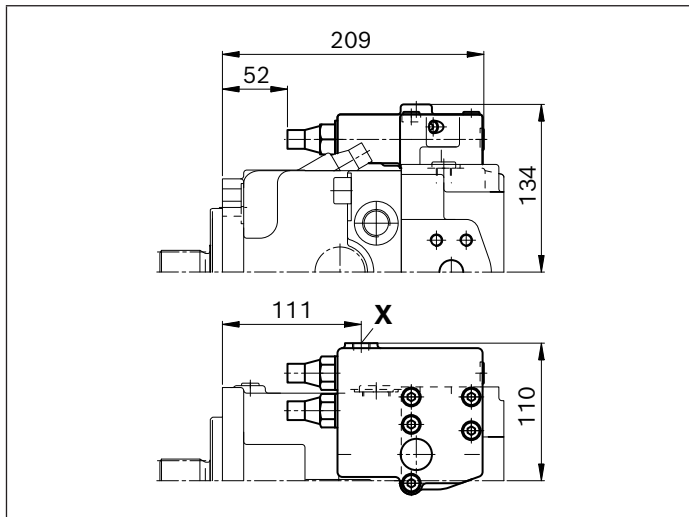

▼ **DRL – Pressure controller, parallel operation**

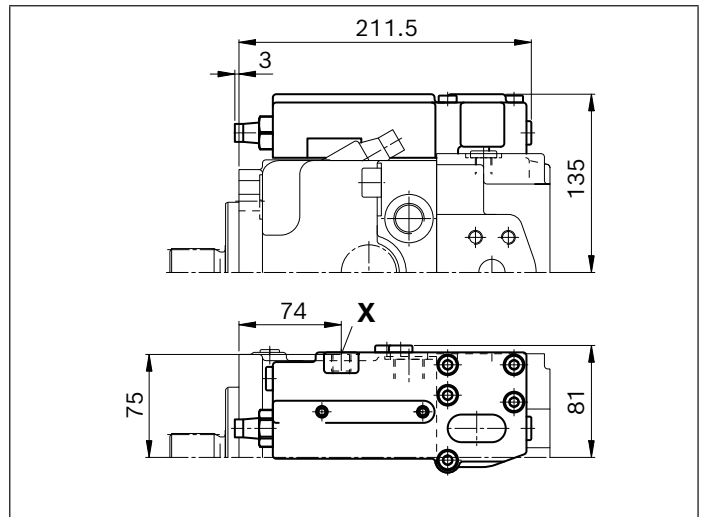

▼ **LE2S – Power controller, electrical override, load sensing (negative control)**

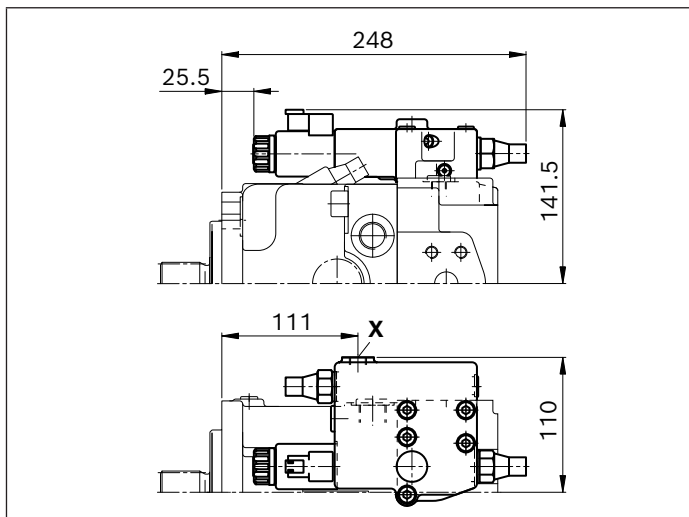

Dimensions, size 60

LRDCS – Power controller with pressure cut-off, cross-sensing and load sensing

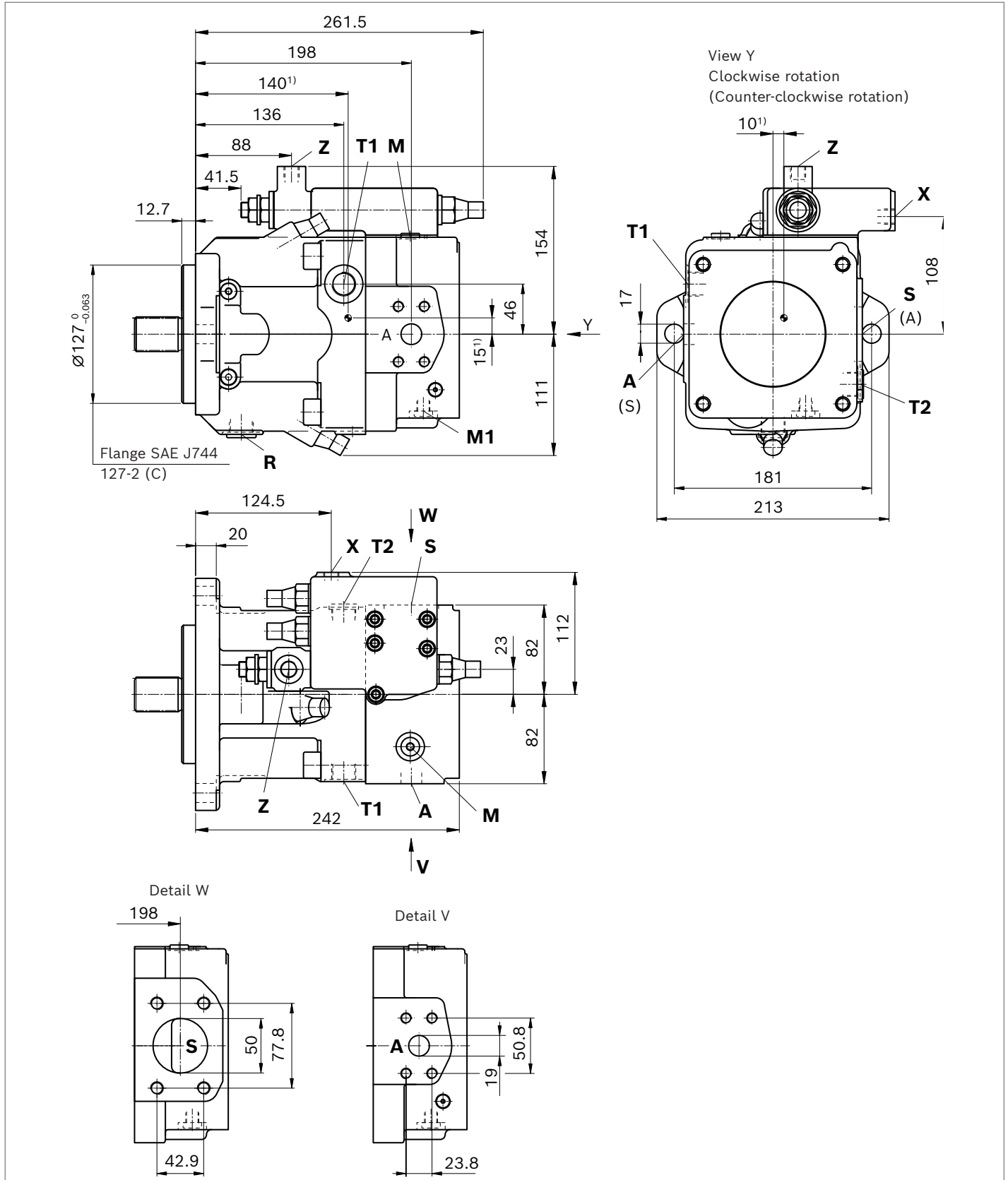

1) Center of gravity.

▼ **Splined shaft DIN 5480**

Z – W35 × 2 × 16 × 9g

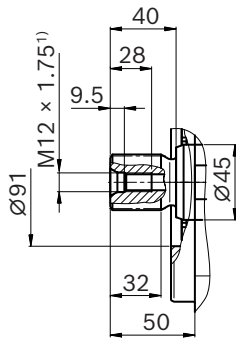

▼ **Parallel keyed shaft DIN 6885**

P – AS 10 × 8 × 56

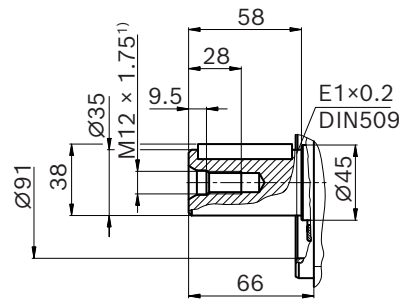

▼ **Splined shaft SAE J744**

S – 1 1/4 in 14T 12/24 DP²⁾

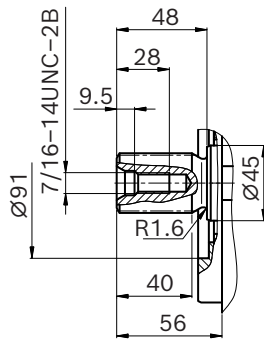

▼ **Splined shaft SAE J744**

T – 1 3/8 in 21T 16/32 DP²⁾

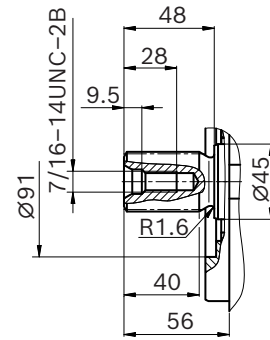

Ports	Standard	Size	p_{max} [bar] ³⁾	State ⁵⁾
A Working port Fastening thread	SAE J518 DIN 13	3/4 in M10 × 1.5; 17 deep	400	O
S Suction port (without charge pump) Fastening thread	SAE J518 DIN 13	2 in M12 × 1.75; 20 deep	30	O
T₁ Drain port	DIN 3852	M22 × 1.5; 14 deep	10	4)
T₂ Drain port	DIN 3852	M22 × 1.5; 14 deep	10	4)
R Air bleed port	DIN 3852	M22 × 1.5; 14 deep	10	X
M₁ Measuring port control pressure	DIN 3852	M12 × 1.5; 12 deep	400	X
M Measuring port pressure A	DIN 3852	M12 × 1.5; 12 deep	400	X
X Pilot pressure port for version with load sensing (S) and remote-controlled pressure cut-off (G)	DIN 3852	M14 × 1.5; 12 deep	400	O
Y Pilot pressure port for version with stroke limiter (H..) and HD	DIN 3852	M14 × 1.5; 12 deep	40	O
Z Pilot pressure port for version with cross sensing (C) and power override (LR3) Power override (LG1)	DIN 3852	M14 × 1.5; 12 deep	400 40	O
G Control pressure port (controller) for version with stroke limiter (H..., U2, U6), HP and EP (otherwise plugged)	DIN 3852	M14 × 1.5; 12 deep	40	O

1) Center bore according to DIN 332 (thread according to DIN 13)
 2) ANSI B92.1a-1976, 30° pressure angle, flat root, side fit, tolerance class 5
 3) Dependent on settings and working pressure

4) Depending on installation position, **T₁** or **T₂** must be connected (see also installation instructions on pages 70 to 73)
 5) O = Must be connected (plugged on delivery)
 X = Plugged (in normal operation)

▼ **LRDH1** – Power controller, pressure cut-off, hydraulic stroke limiter (negative control)

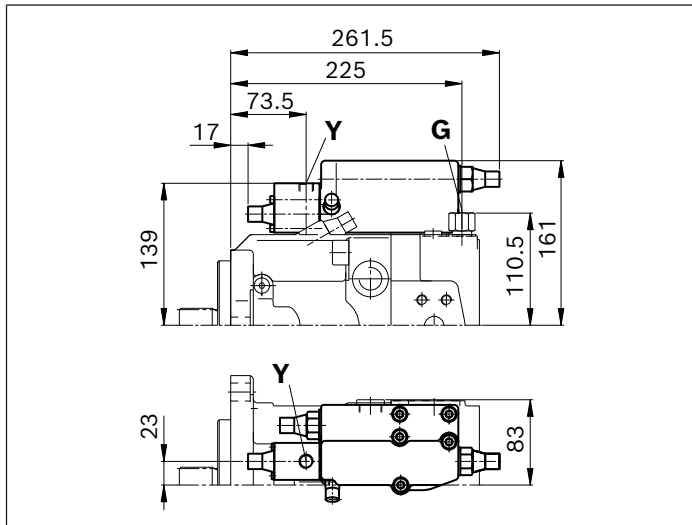

▼ **LRDH2** – Power controller, pressure cut-off, hydraulic stroke limiter (positive control)

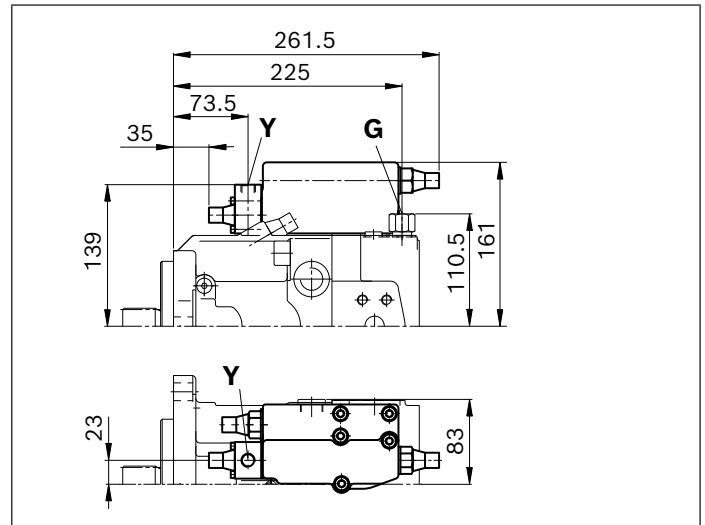

▼ **LRDU2** – Power controller, pressure cut-off, hydraulic stroke limiter (positive control)

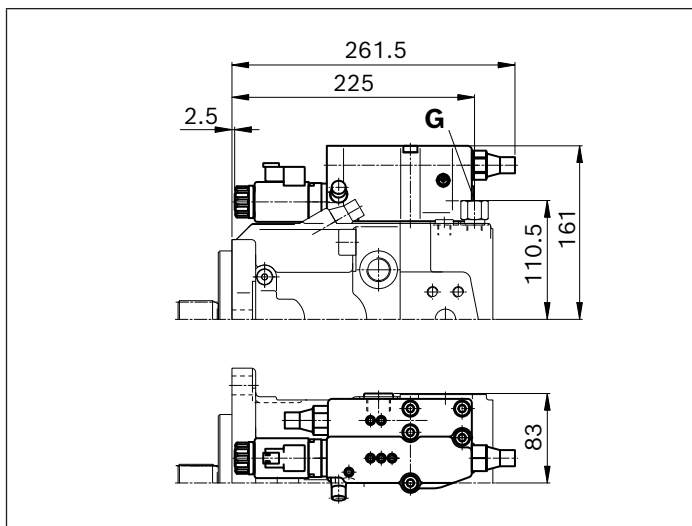

▼ **LR3DS** – Power controller, high-pressure-dependent override, pressure cut-off, load sensing

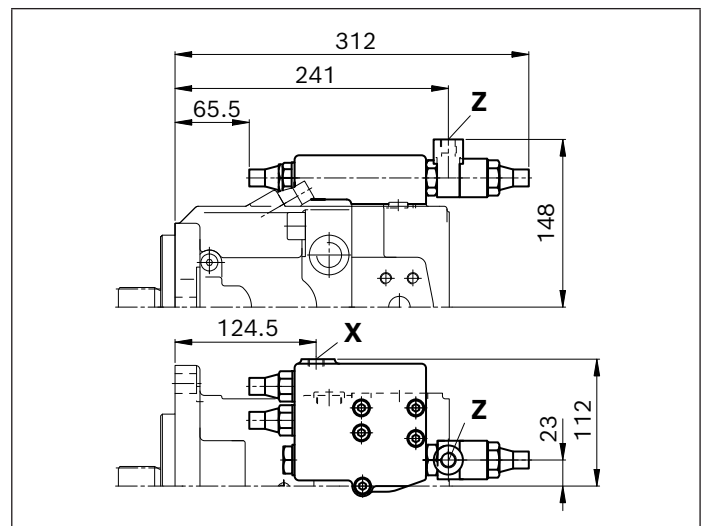

▼ **HD2D** – Hydraulic, pilot-pressure related control, pressure cut-off

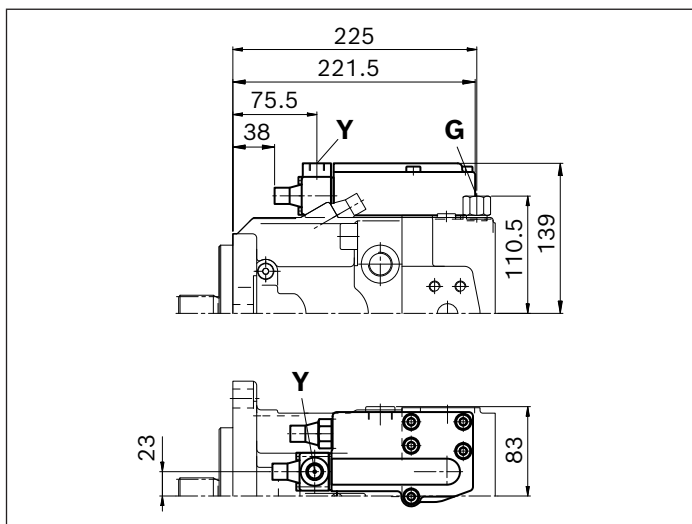

▼ **EP2D** – Electric control, proportional solenoid, pressure cut-off

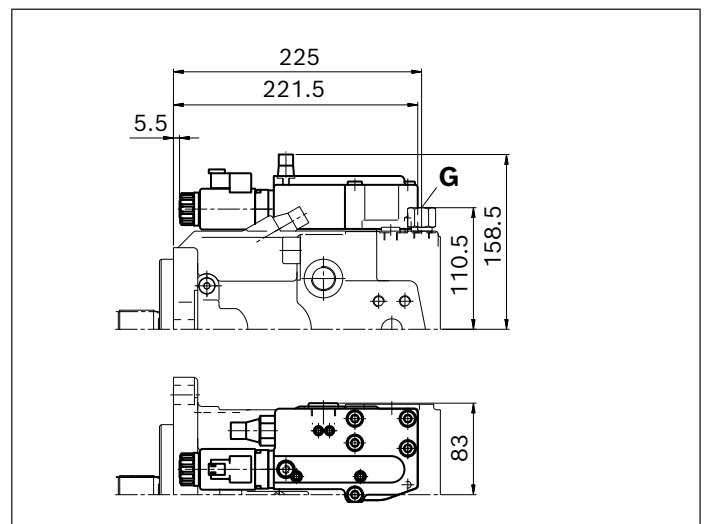

▼ **DRS/DRG – Remote-controlled pressure controller, load sensing**

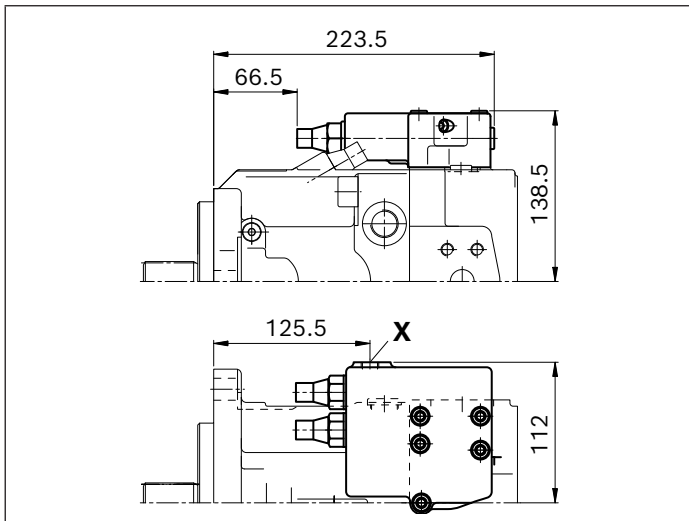

▼ **DRL – Pressure controller, parallel operation**

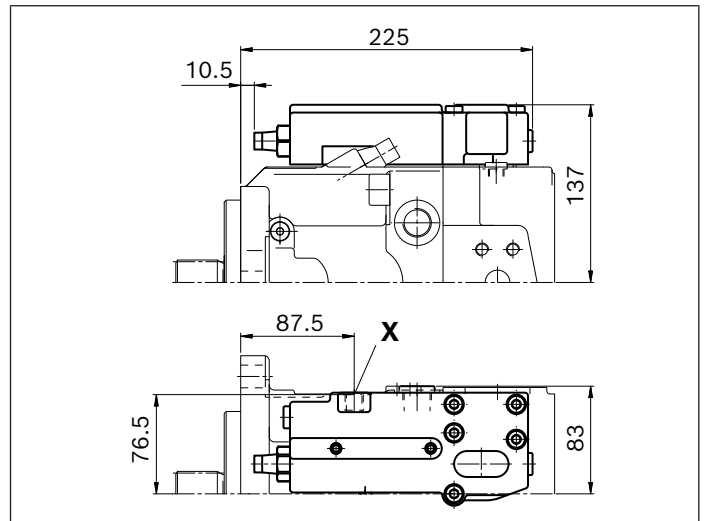

▼ **LE2S – Power controller, electrical override, load sensing (negative control)**

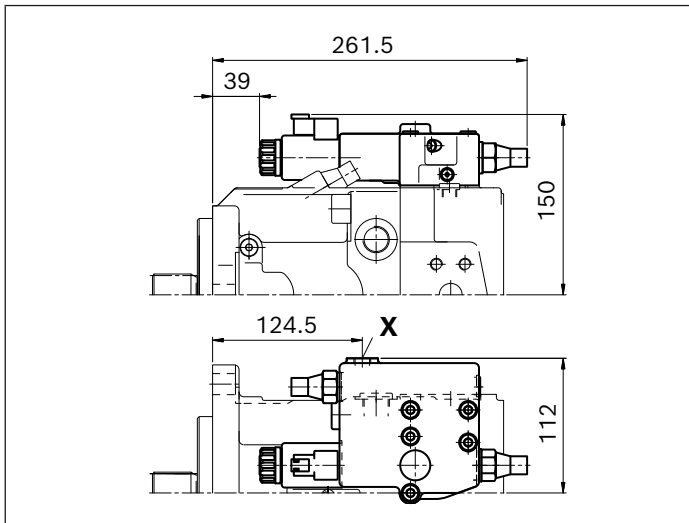

Dimensions, size 75

LRDCS – Power controller with pressure cut-off, cross-sensing and load sensing

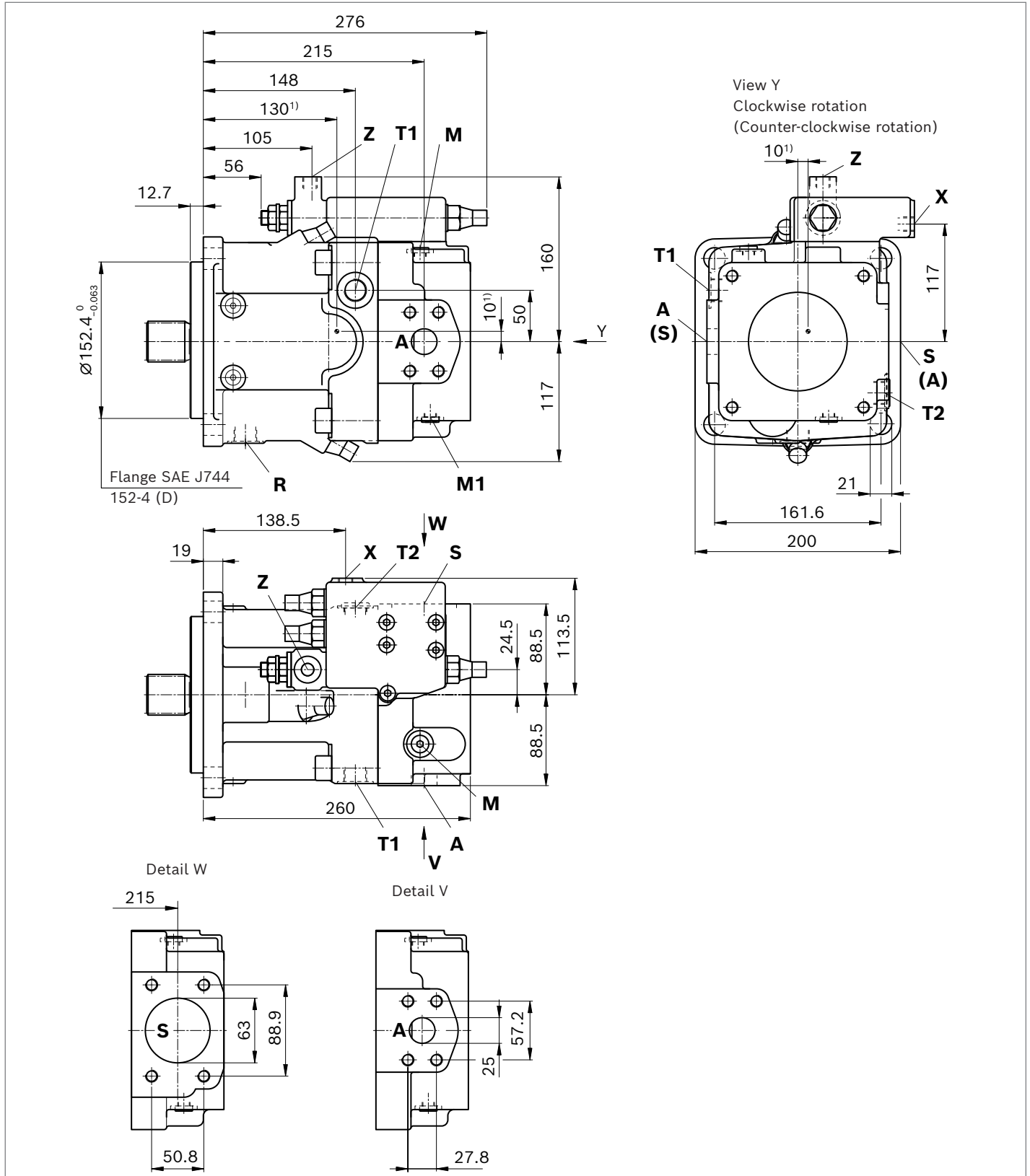

1) Center of gravity.

▼ **Splined shaft DIN 5480**

Z – W 40 × 2 × 18 × 9g

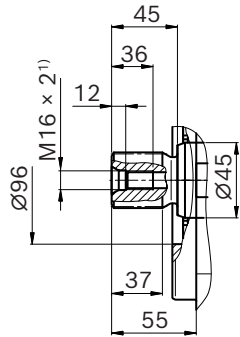

▼ **Parallel keyed shaft DIN 6885**

P – AS 12 × 8 × 80

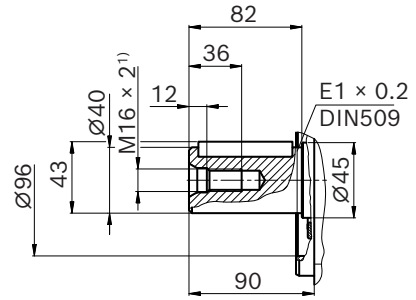

▼ **Splined shaft SAE J744**

S – 1 1/4 in 14T 12/24 DP²⁾

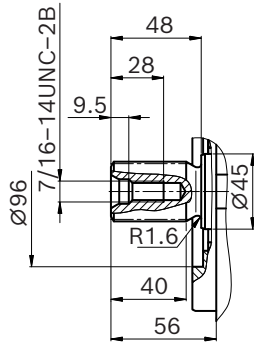

▼ **Splined shaft SAE J744**

T – 1 3/8 in 21T 16/32 DP²⁾

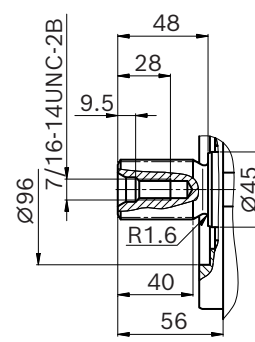

Ports		Standard	Size	p_{max} [bar] ³⁾	State ⁵⁾
A	Working port Fastening thread	SAE J518 DIN 13	1 in M12 × 1.75; 17 deep	400	O
S	Suction port (without charge pump) Fastening thread	SAE J518 DIN 13	2 1/2 in M12 × 1.75; 17 deep	30	O
T₁	Drain port	DIN 3852	M22 × 1.5; 14 deep	10	4)
T₂	Drain port	DIN 3852	M22 × 1.5; 14 deep	10	4)
R	Air bleed port	DIN 3852	M22 × 1.5; 14 deep	10	X
M₁	Measuring port control pressure	DIN 3852	M12 × 1.5; 12 deep	400	X
M	Measuring port pressure A	DIN 3852	M12 × 1.5; 12 deep	400	X
X	Pilot pressure port for version with load sensing (S) and remote-controlled pressure cut-off (G)	DIN 3852	M14 × 1.5; 12 deep	400	O
Y	Pilot pressure port for version with stroke limiter (H..) and HD	DIN 3852	M14 × 1.5; 12 deep	40	O
Z	Pilot pressure port for version with cross sensing (C) and power override (LR3) Power override (LG1)	DIN 3852	M14 × 1.5; 12 deep	400 40	O
G	Control pressure port (controller) for version with stroke limiter (H.., U2, U6), HP and EP (otherwise plugged)	DIN 3852	M14 × 1.5; 12 deep	40	O

1) Center bore according to DIN 332 (thread according to DIN 13)

2) ANSI B92.1a-1976, 30° pressure angle, flat root, side fit, tolerance class 5

3) Dependent on settings and working pressure

4) Depending on installation position, **T₁** or **T₂** must be connected (see also installation instructions on pages 70 to 73)

5) O = Must be connected (plugged on delivery)
X = Plugged (in normal operation)

▼ **LRDH1** – Power controller, pressure cut-off, hydraulic stroke limiter (negative control)

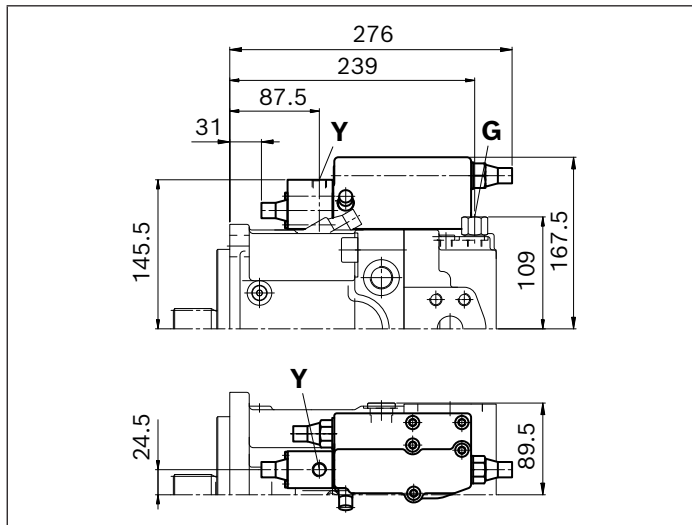

▼ **LRDH2** – Power controller, pressure cut-off, hydraulic stroke limiter (positive control)

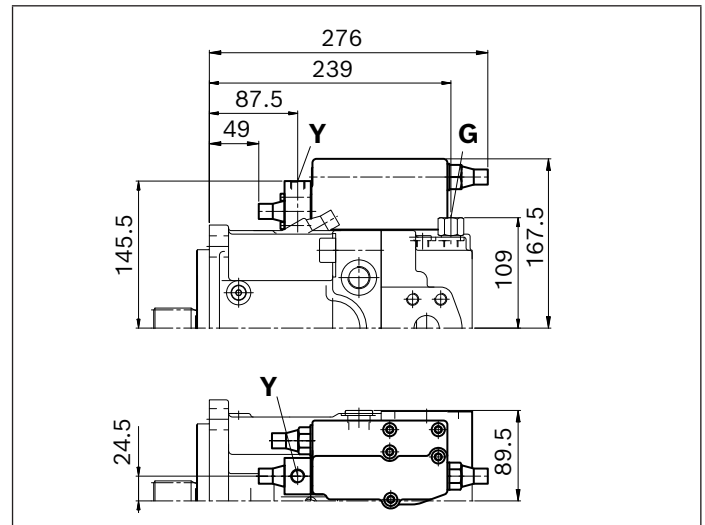

▼ **LRDU2** – Power controller, pressure cut-off, hydraulic stroke limiter (positive control)

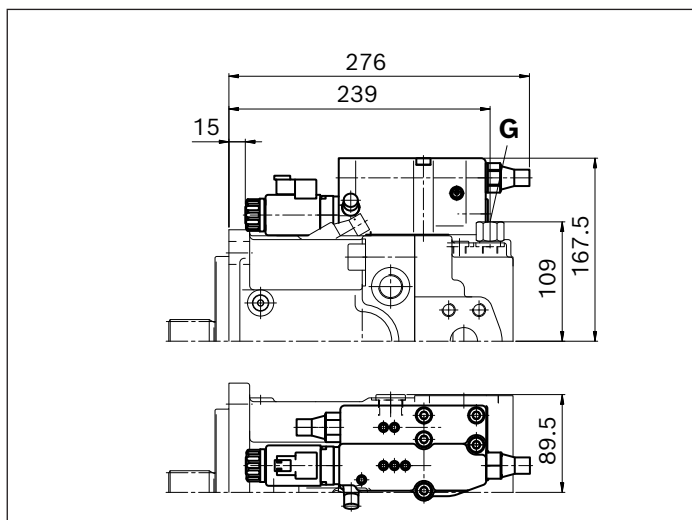

▼ **LR3DS** – Power controller, high-pressure-dependent override, pressure cut-off, load sensing

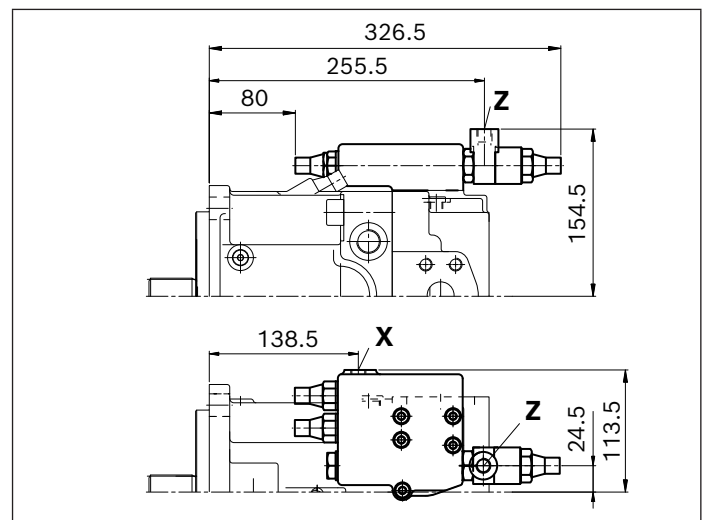

▼ **HD2D** – Hydraulic, pilot-pressure related control, pressure cut-off

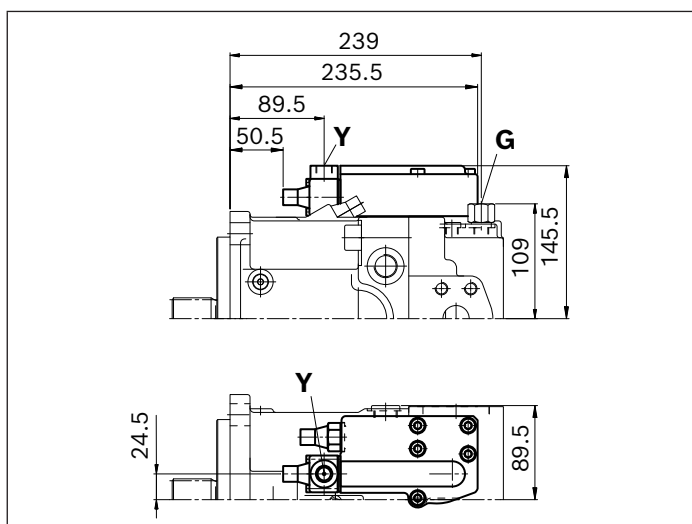

▼ **EP2D** – Electric control, proportional solenoid, pressure cut-off

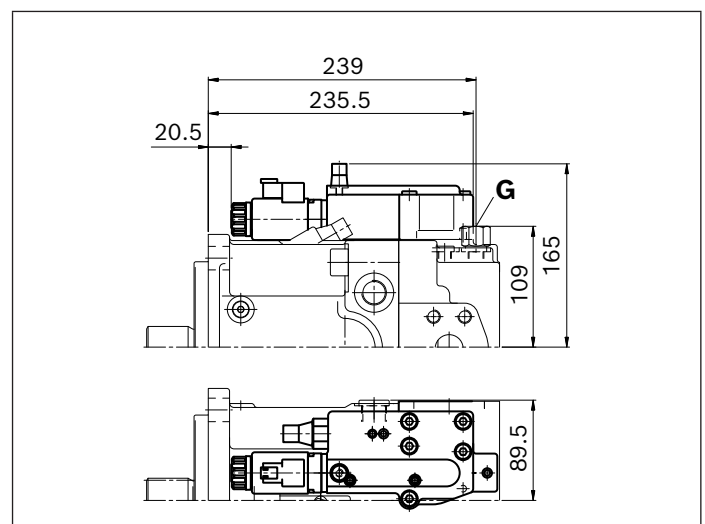

▼ **DRS/DRG – Remote-controlled pressure controller, load sensing**

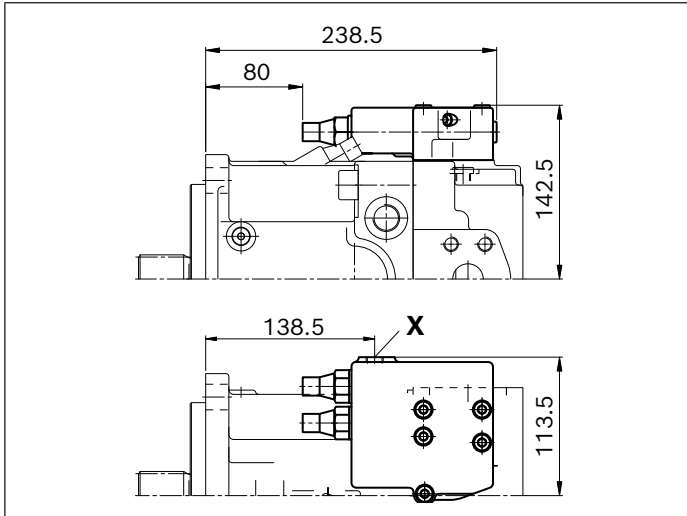

▼ **DRL – Pressure controller, parallel operation**

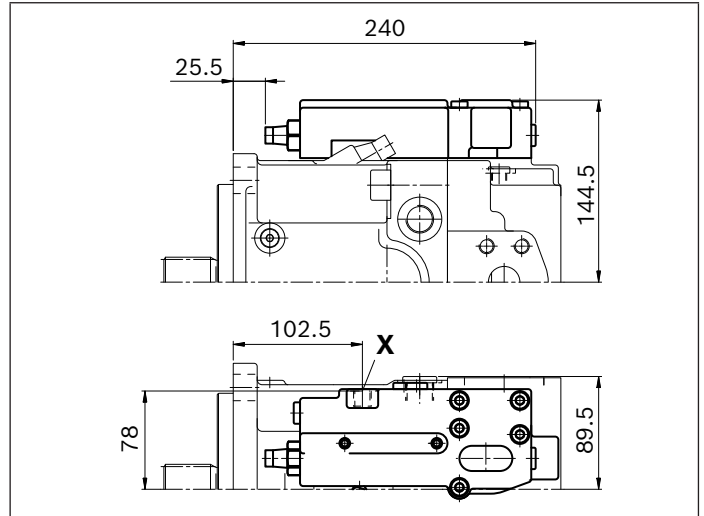

▼ **LE2S – Power controller, electrical override, load sensing (negative control)**

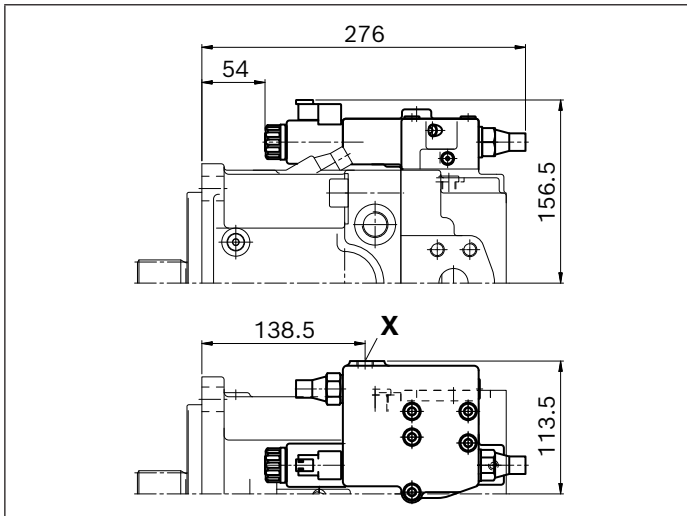

Dimensions, size 95

LRDCS – Power controller with pressure cut-off, cross-sensing and load sensing

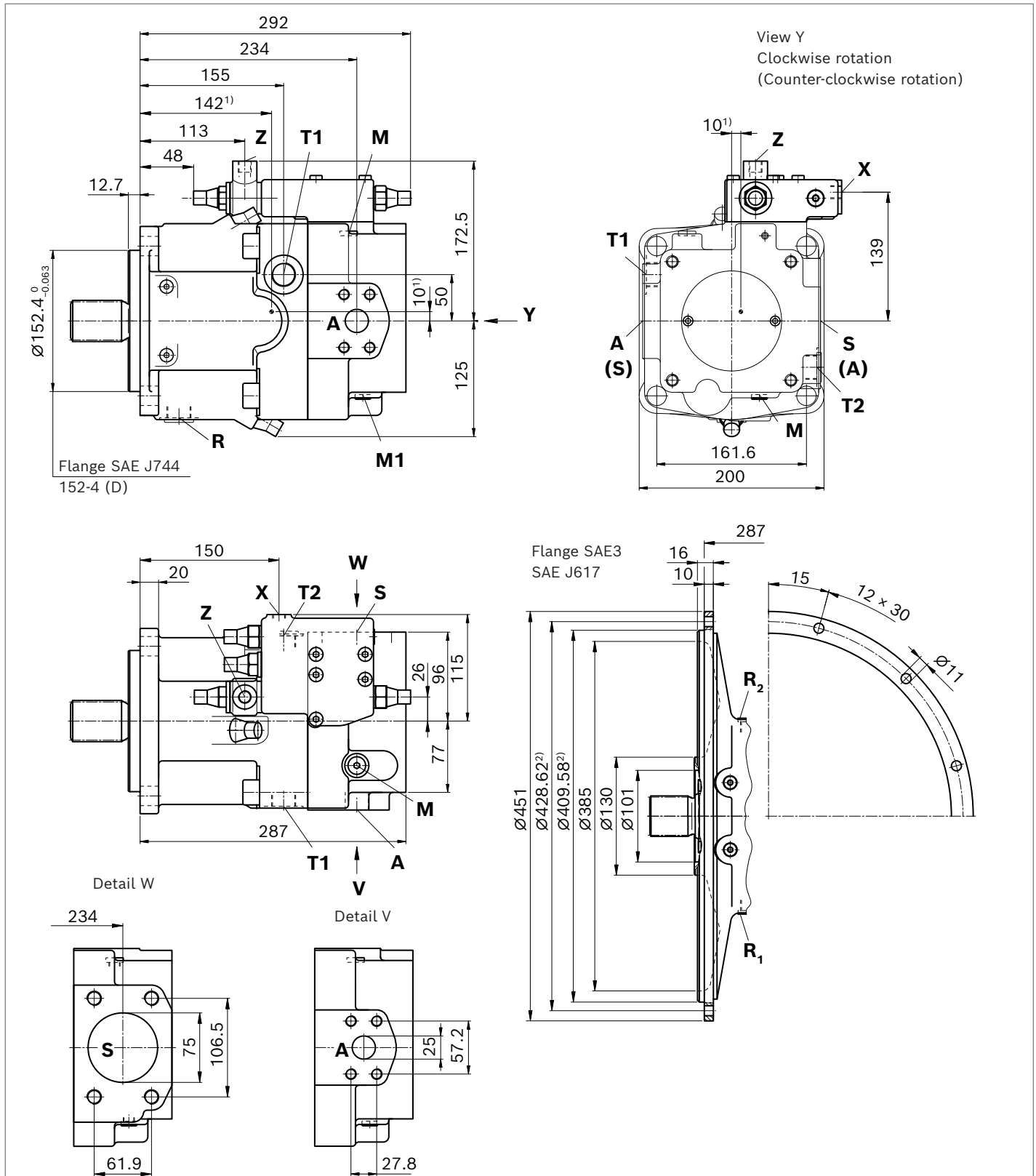

1) Center of gravity.

2) Dimensions according to SAE J617-No. 3, for connection to the flywheel housing of the combustion engine

▼ Splined shaft DIN 5480

Z – W 45 × 2 × 21 × 9g

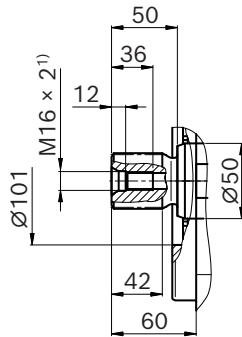

▼ Parallel keyed shaft DIN 6885

P – AS 14 × 9 × 80

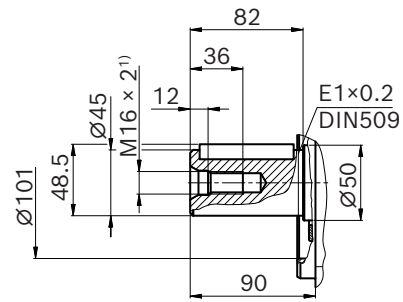

▼ Splined shaft SAE J744

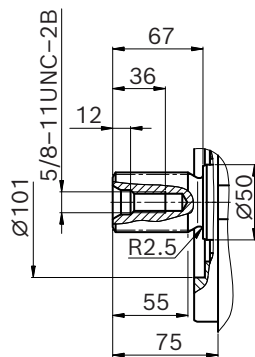
S – 1 3/4 in 13T 8/16 DP²⁾

Ports	Standard	Size	p_{max} [bar] ³⁾	State ⁵⁾
A Working port Fastening thread	SAE J518 DIN 13	1 in M12 × 1.75; 17 deep	400	O
S Suction port (without charge pump) Fastening thread	SAE J518 DIN 13	3 in M16 × 2; 24 deep	30	O
T₁ Drain port	DIN 3852	M26 × 1.5; 16 deep	10	4)
T₂ Drain port	DIN 3852	M26 × 1.5; 16 deep	10	4)
R Air bleed port (flange SAE J744)	DIN 3852	M26 × 1.5; 16 deep	10	X
R₁ Air bleed port (flange SAE 3)	DIN 3852	M26 × 1.5; 16 deep	10	X
R₂ Air bleed port (flange SAE 3)	DIN 3852	M26 × 1.5; 16 deep	10	X
M₁ Measuring port control pressure	DIN 3852	M12 × 1.5; 12 deep	400	X
M Measuring port pressure A	DIN 3852	M12 × 1.5; 12 deep	400	X
X Pilot pressure port for version with load sensing (S) and remote-controlled pressure cut-off (G)	DIN 3852	M14 × 1.5; 12 deep	400	O
Y Pilot pressure port in version with stroke limiter (H...) and 2-stage pressure cut-off (E) and HD	DIN 3852	M14 × 1.5; 12 deep	40	O
Z Pilot pressure port for version with cross sensing (C) and power override (LR3) Power override (LG1) Load sensing override (S5)	DIN 3852	M14 × 1.5; 12 deep	400 40 30	O
G Control pressure port (controller) for version with stroke limiter (H..., U2, U6), HP and EP (otherwise plugged)	DIN 3852	M14 × 1.5; 12 deep	40	O

- Center bore according to DIN 332 (thread according to DIN 13)
- ANSI B92.1a-1976, 30° pressure angle, flat root, side fit, tolerance class 5
- Dependent on settings and working pressure

- Depending on installation position, **T₁** or **T₂** must be connected (see also installation instructions on pages 70 to 73)
- O = Must be connected (plugged on delivery)
X = Plugged (in normal operation)

▼ **LRDH1 - Power controller, pressure cut-off, hydraulic stroke limiter (negative control)**

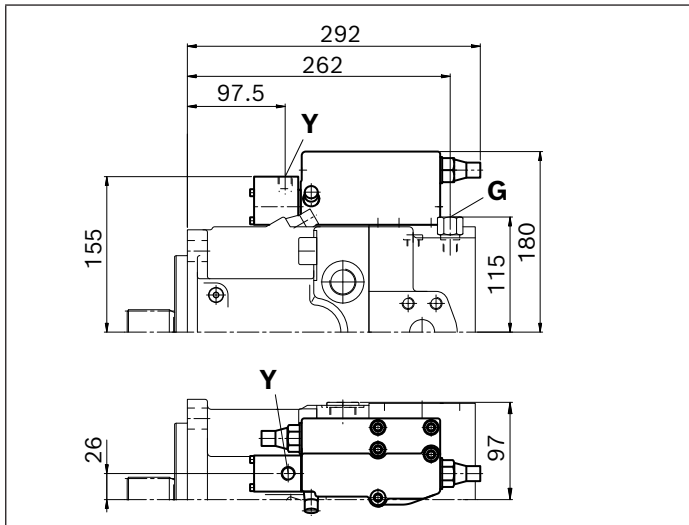

▼ **LRDH2 - Power controller, pressure cut-off, hydraulic stroke limiter (positive control)**

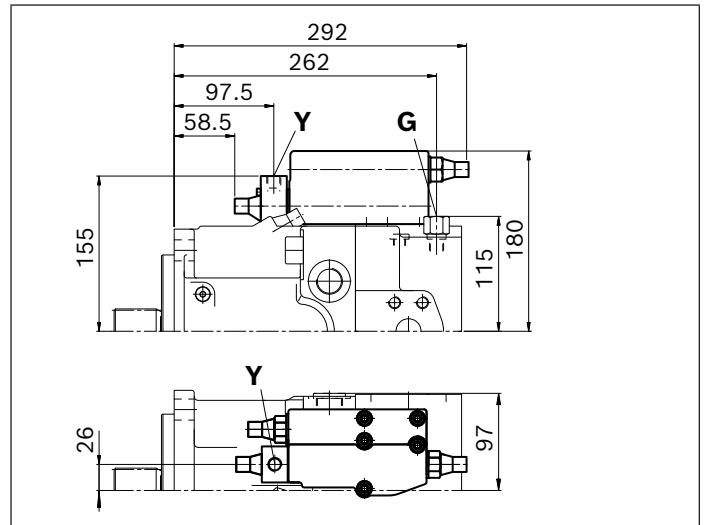

▼ **LRDU2 - Power controller, pressure cut-off, hydraulic stroke limiter (positive control)**

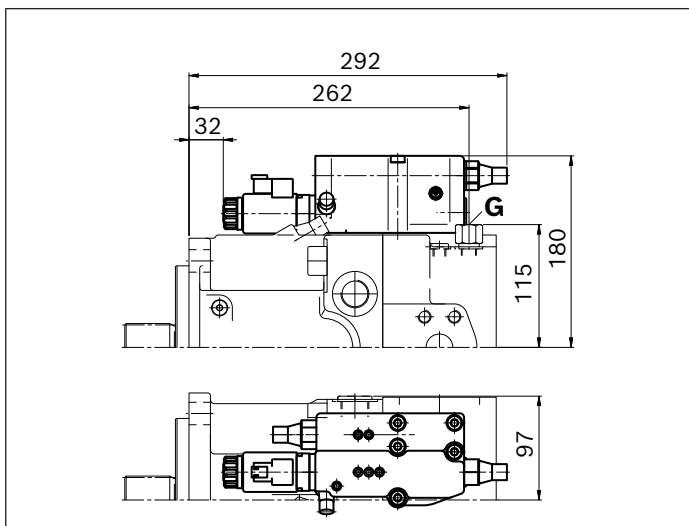

▼ **LR3DS - Power controller, high-pressure-dependent override, pressure cut-off, load sensing**

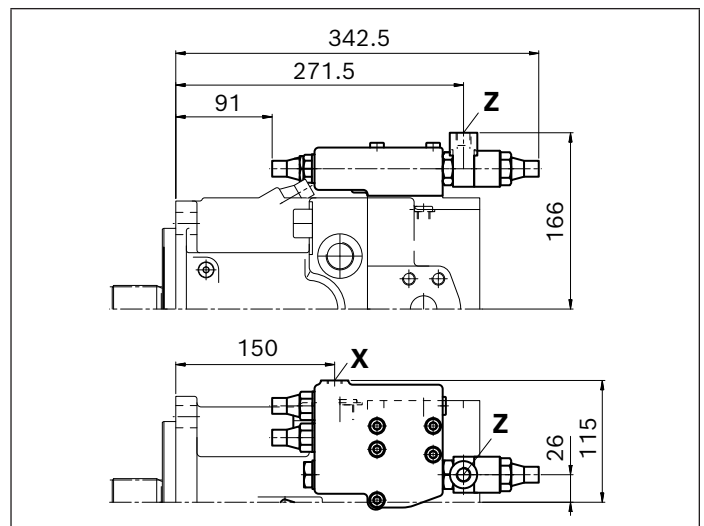

▼ **LG1DS - Power controller, pilot-pressure related override, pressure cut-off, load sensing (negative control)**

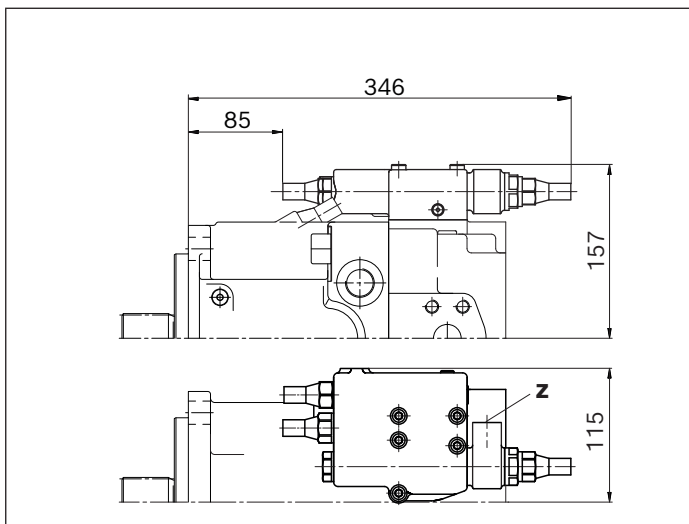

▼ **HD2D - Hydraulic, pilot-pressure related control, pressure cut-off**

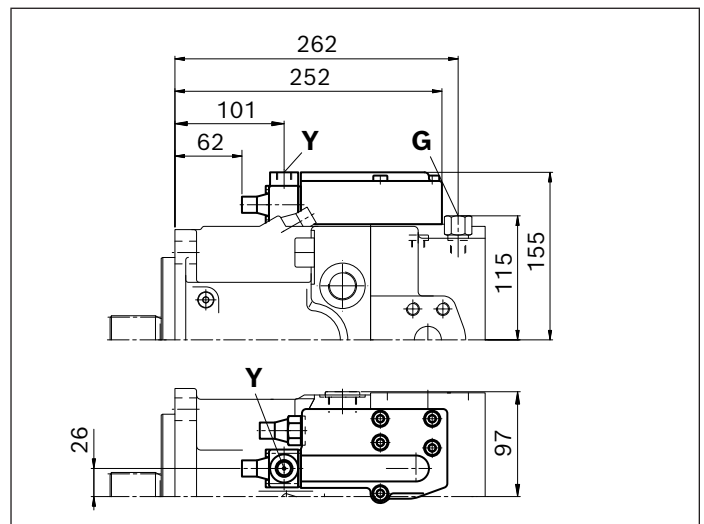

▼ **EP2D – Electric control, proportional solenoid, pressure cut-off**

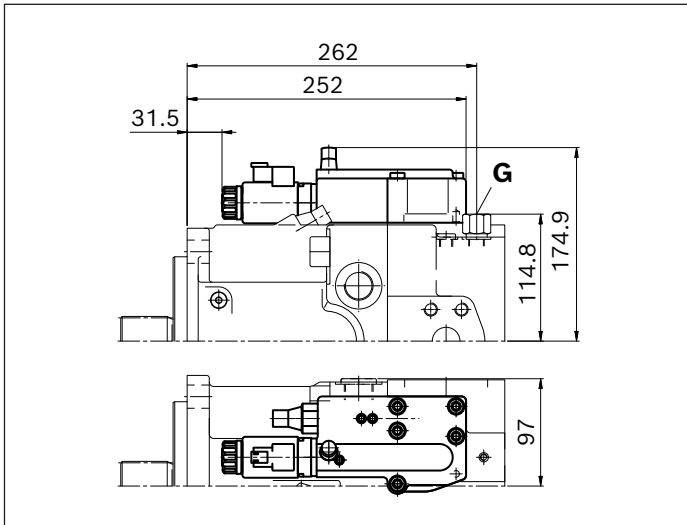

▼ **EP2G2/EP2G4 – Electric control with electrically overridable pressure cut-off (positive/negative control)**

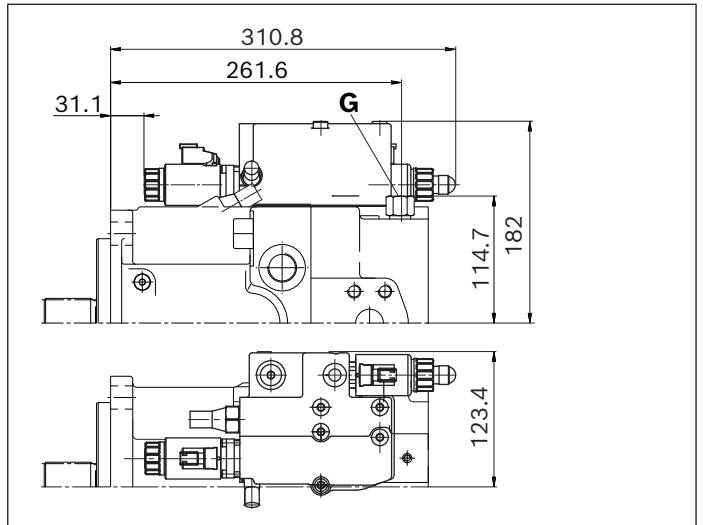

▼ **DRS/DRG – Remote-controlled pressure controller, load sensing**

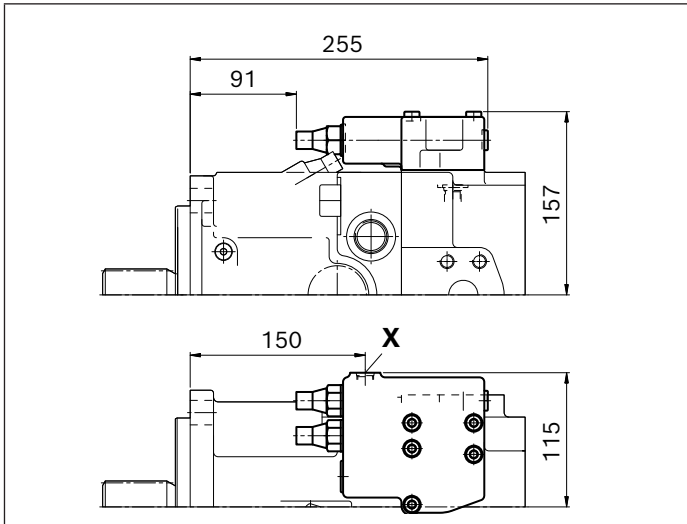

▼ **DRL – Pressure controller, parallel operation**

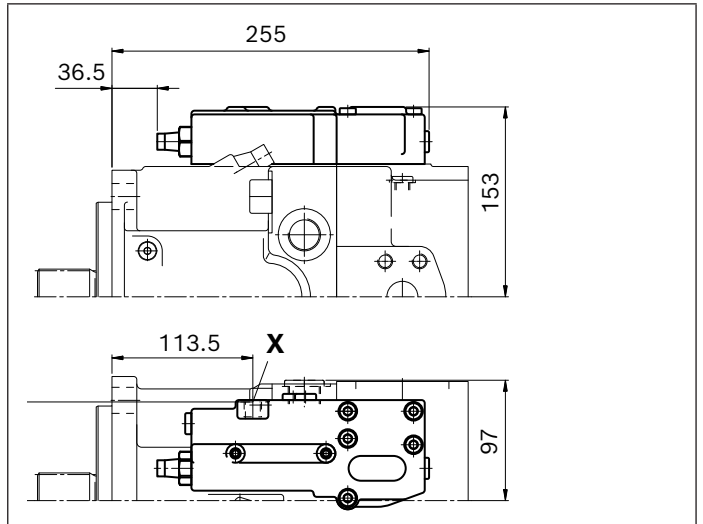

▼ **LE2S – Power controller, electrical override, load sensing (negative control)**

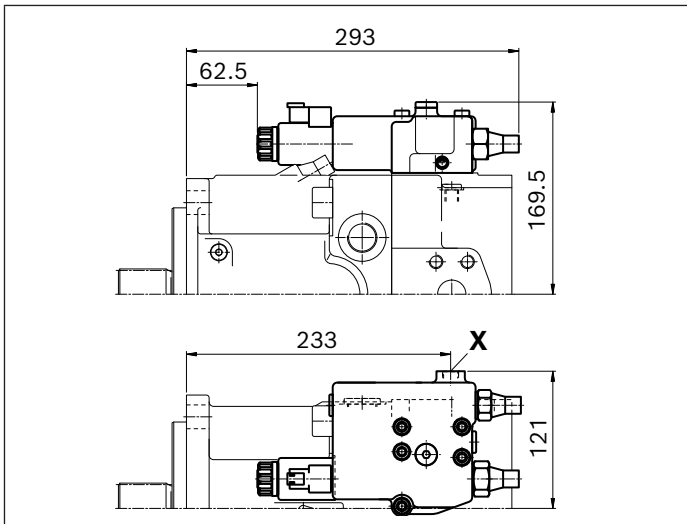

▼ **LE2S2/LE2S5 – Power controller, electrical override, load sensing, overridable**

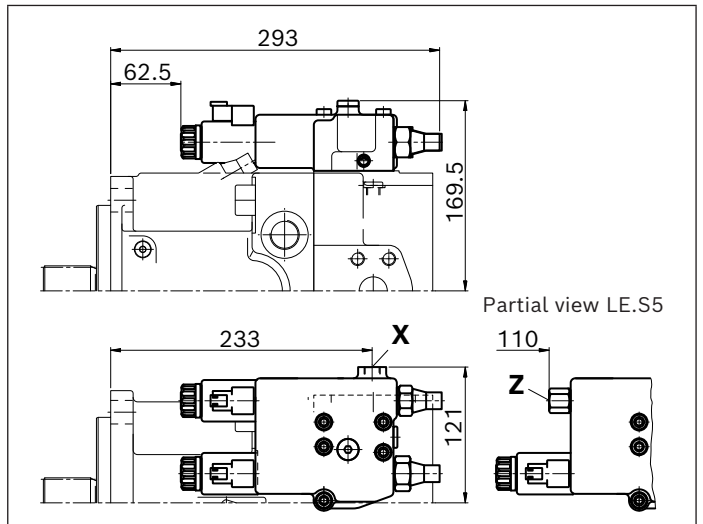

Dimensions, size 130/145

LRDCS – Power controller with pressure cut-off, cross-sensing and load sensing

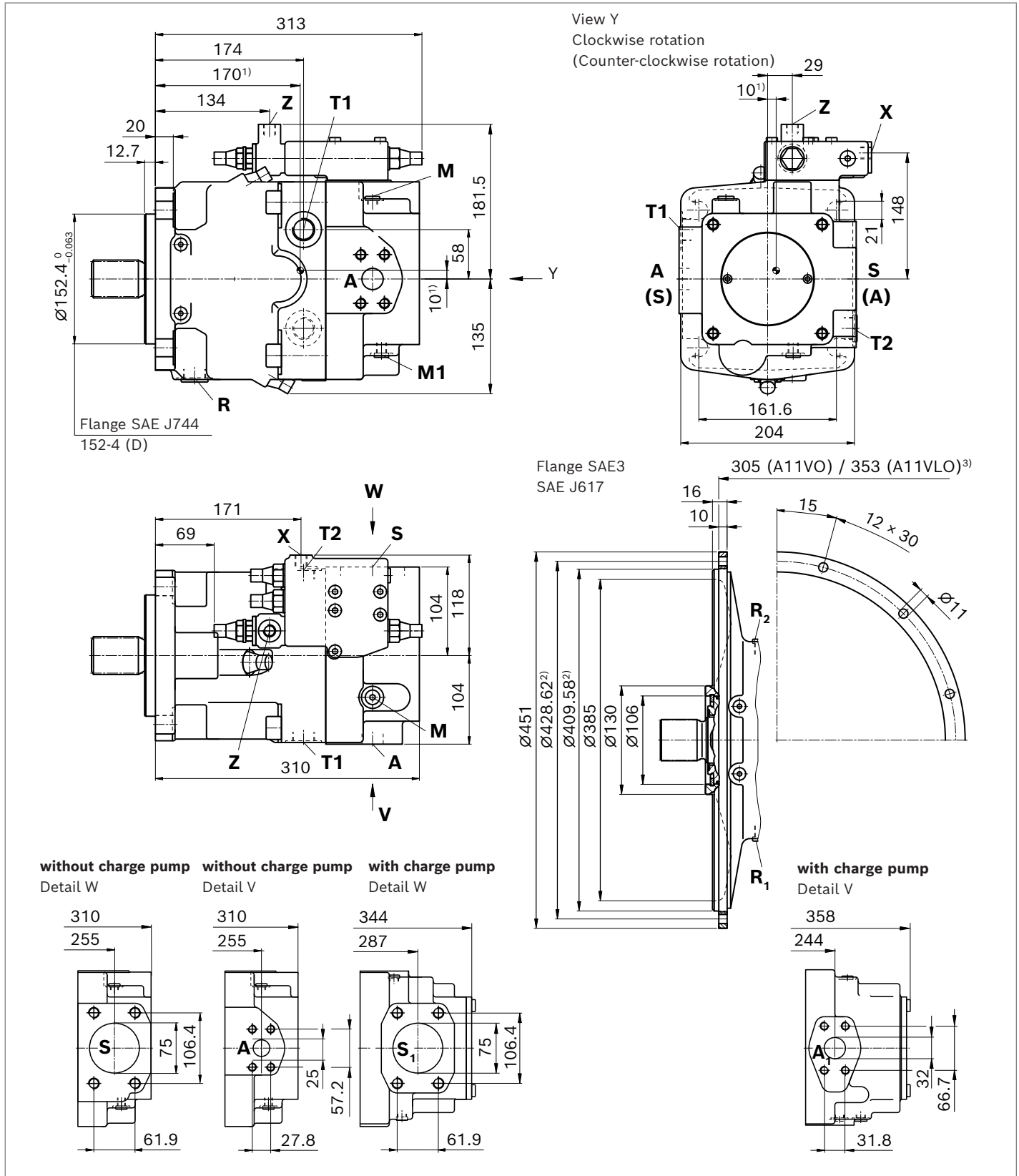

1) Center of gravity.

2) Dimensions according to SAE J617-No. 3, for connection to the flywheel housing of the combustion engine

3) The housing or length dimension with flange SAE J617-No.3 is 5 mm shorter than the standard housing.

▼ **Splined shaft DIN 5480**

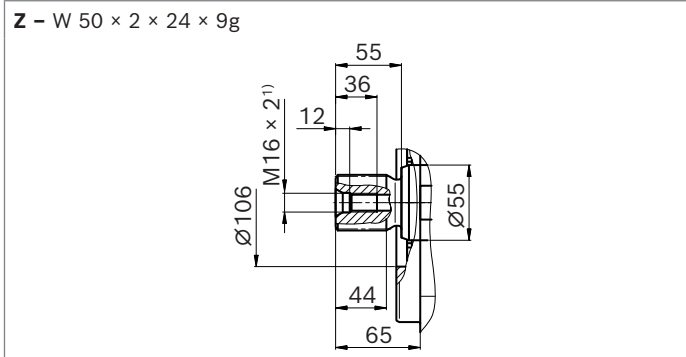

▼ **Parallel keyed shaft DIN 6885**

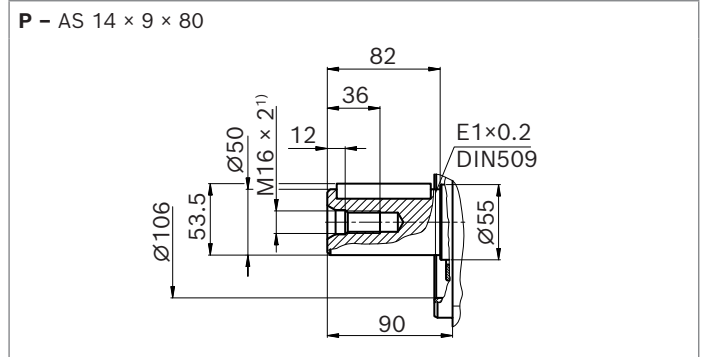

▼ **Splined shaft SAE J744**

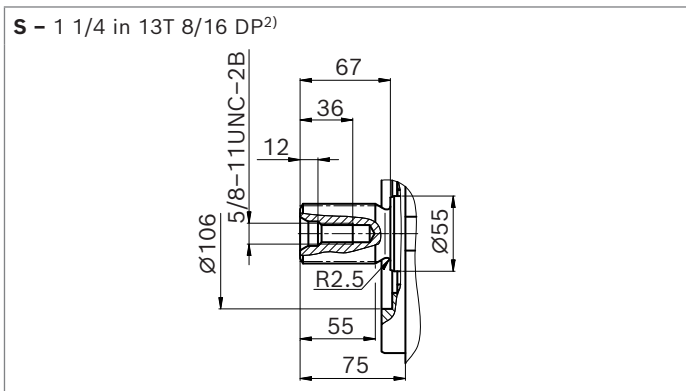

Ports	Standard	Size	p_{max} [bar] ³⁾	State ⁵⁾
A Working port Fastening thread	SAE J518 DIN 13	1 in M12 × 1.75; 17 deep	400	O
A₁ Working port Fastening thread	SAE J518 DIN 13	1 1/4 in M14 × 2; 19 deep	400	O
S Suction port (without charge pump) Fastening thread	SAE J518 DIN 13	3 in M16 × 2; 24 deep	30	O
S₁ Suction port (with charge pump) Fastening thread	SAE J518 DIN 13	3 in M16 × 2; 24 deep	2	O
T₁ Drain port	DIN 3852	M26 × 1.5; 16 deep	10	4)
T₂ Drain port	DIN 3852	M26 × 1.5; 16 deep	10	4)
R Air bleed port (flange SAE J744)	DIN 3852	M26 × 1.5; 16 deep	10	X
R₁ Air bleed port (flange SAE 3)	DIN 3852	M26 × 1.5; 16 deep	10	X
R₂ Air bleed port (flange SAE 3)	DIN 3852	M26 × 1.5; 16 deep	10	X
M₁ Measuring port control pressure	DIN 3852	M12 × 1.5; 12 deep	400	X
M Measuring port pressure A	DIN 3852	M12 × 1.5; 12 deep	400	X
X Pilot pressure port for version with load sensing (S) and remote-controlled pressure cut-off (G)	DIN 3852	M14 × 1.5; 12 deep	400	O
Y Pilot pressure port in version with stroke limiter (H...) and 2-stage pressure cut-off (E) and HD	DIN 3852	M14 × 1.5; 12 deep	40	O
Z Pilot pressure port for version with cross sensing (C) and power override (LR3) Power override (LG1) Load sensing override (S5)	DIN 3852	M14 × 1.5; 12 deep	400 40 30	O
G Control pressure port (controller) for version with stroke limiter (H..., U2, U6), HP and EP	DIN 3852	M14 × 1.5; 12 deep	40	O

1) Center bore according to DIN 332 (thread according to DIN 13)
 2) ANSI B92.1a-1976, 30° pressure angle, flat root, side fit, tolerance class 5
 3) Dependent on settings and working pressure

4) Depending on installation position, **T₁** or **T₂** must be connected (see also installation instructions on pages 70 to 73)
 5) O = Must be connected (plugged on delivery)
 X = Plugged (in normal operation)

▼ **LRDH1** – Power controller, pressure cut-off, hydraulic stroke limiter (negative control)

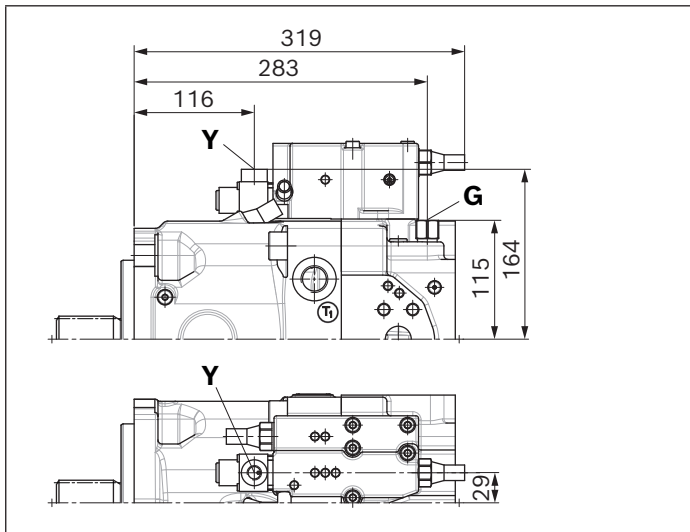

▼ **LRDH2** – Power controller, pressure cut-off, hydraulic stroke limiter (positive control)

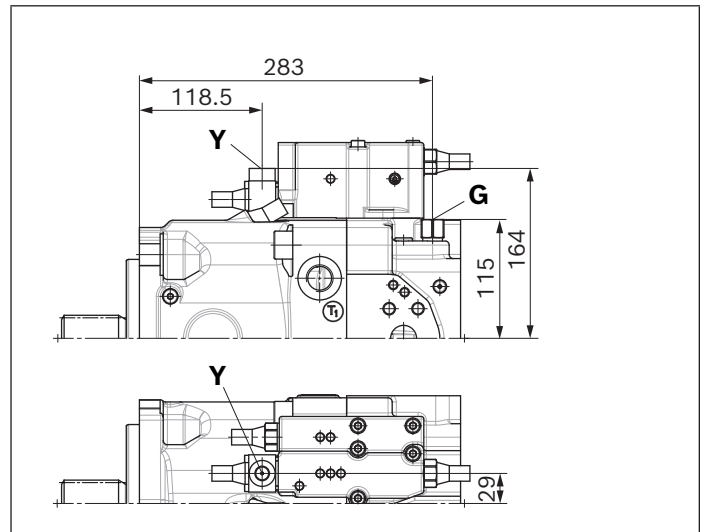

▼ **LRDU2** – Power controller, pressure cut-off, hydraulic stroke limiter (positive control)

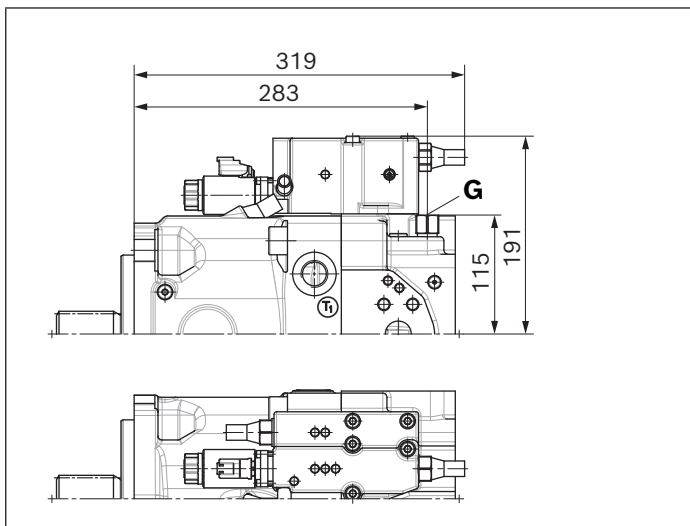

▼ **LR3DS** – Power controller, high-pressure-dependent override, pressure cut-off, load sensing

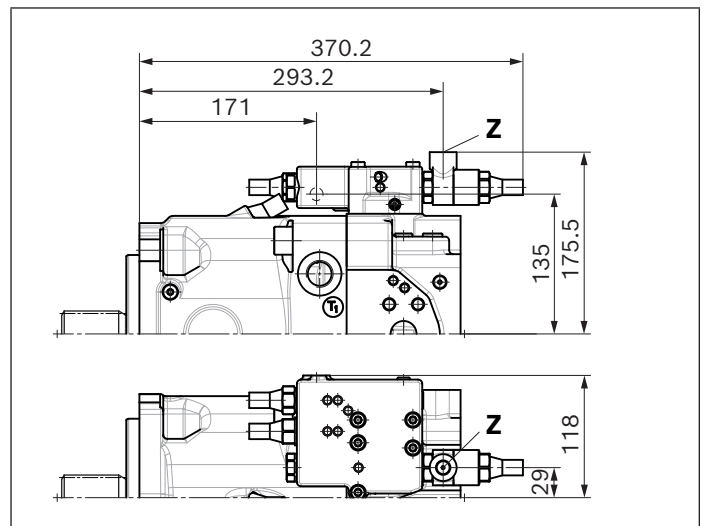

▼ **HD2D** – Hydraulic, pilot-pressure related control, pressure cut-off

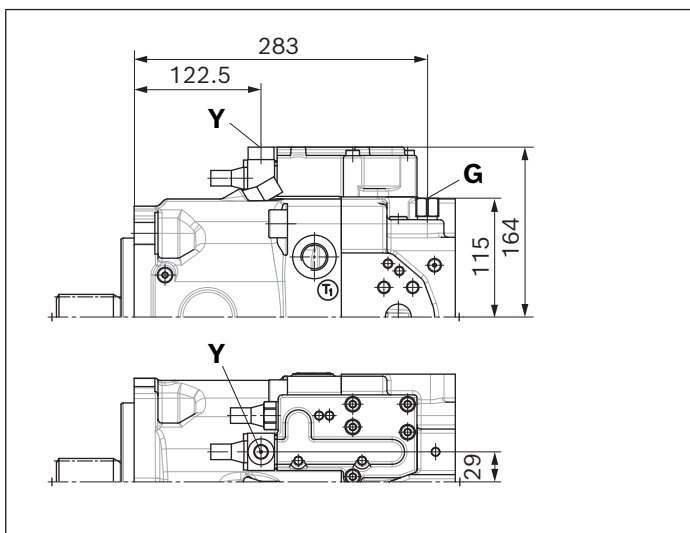

▼ **EP2D** – Electric control, proportional solenoid, pressure cut-off

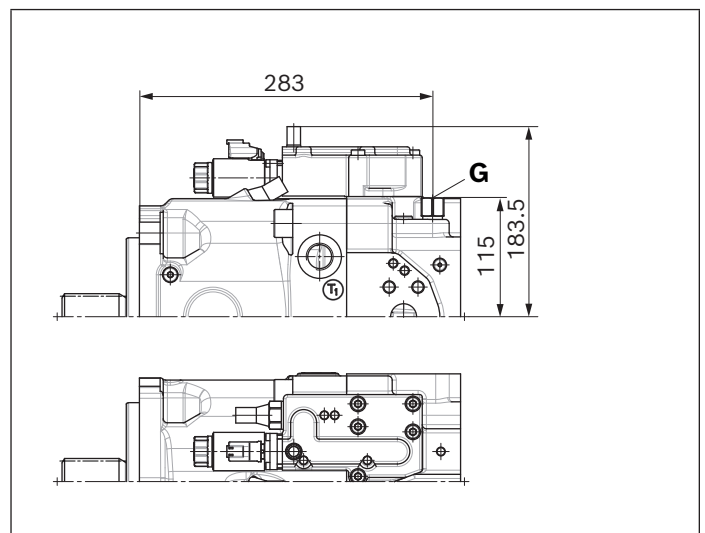

▼ **EP2G2/EP2G4 - Electric control with electrically overridable pressure cut-off (positive/negative control)**

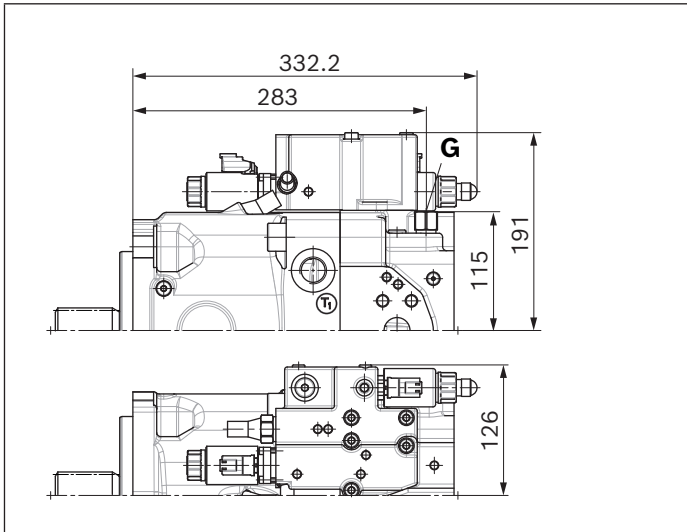

▼ **DRS/DRG - Remote-controlled pressure controller, load sensing**

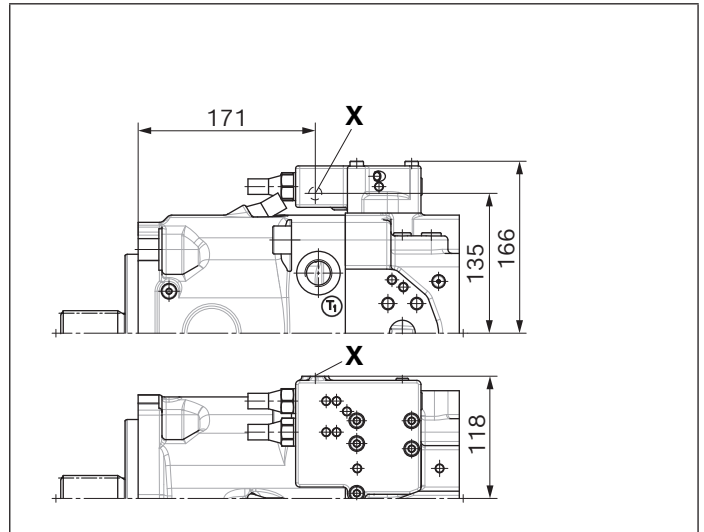

▼ **DRL - Pressure controller, parallel operation**

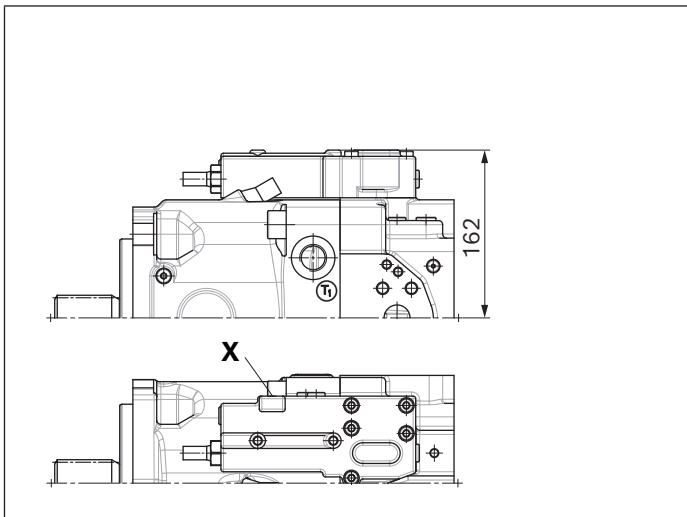

▼ **LE2S - Power controller, electrical override, load sensing (negative control)**

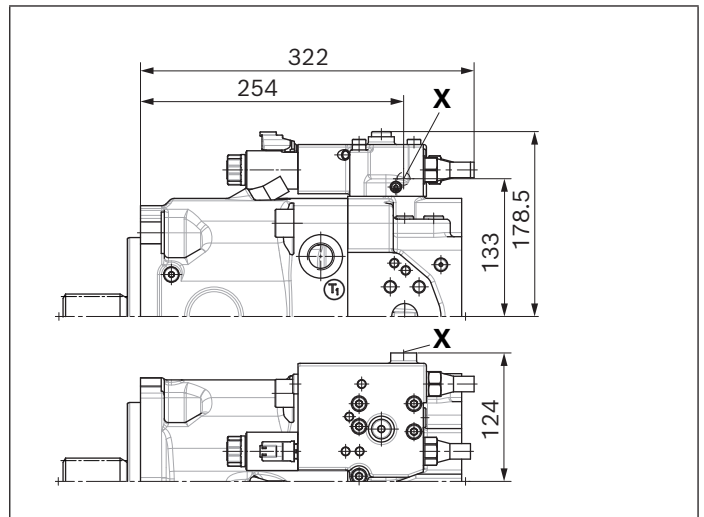

▼ **LE2S2/LE2S5 - Power controller, electrical override, load sensing, overridable**

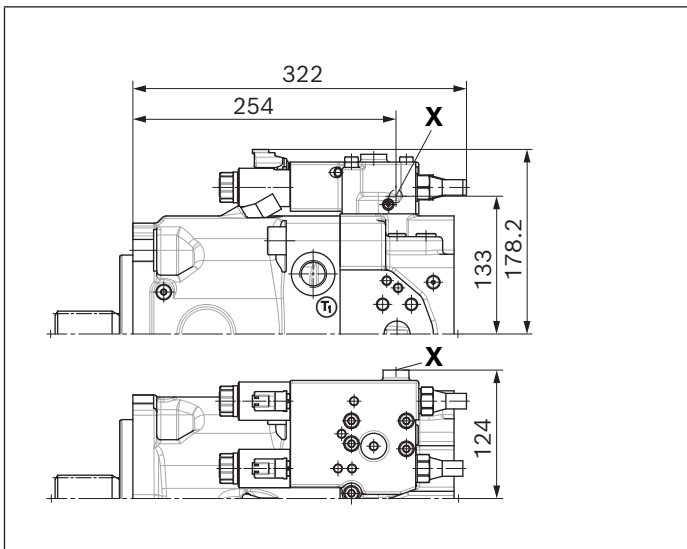

Dimensions, size 190

LRDCS – Power controller with pressure cut-off, cross-sensing and load sensing

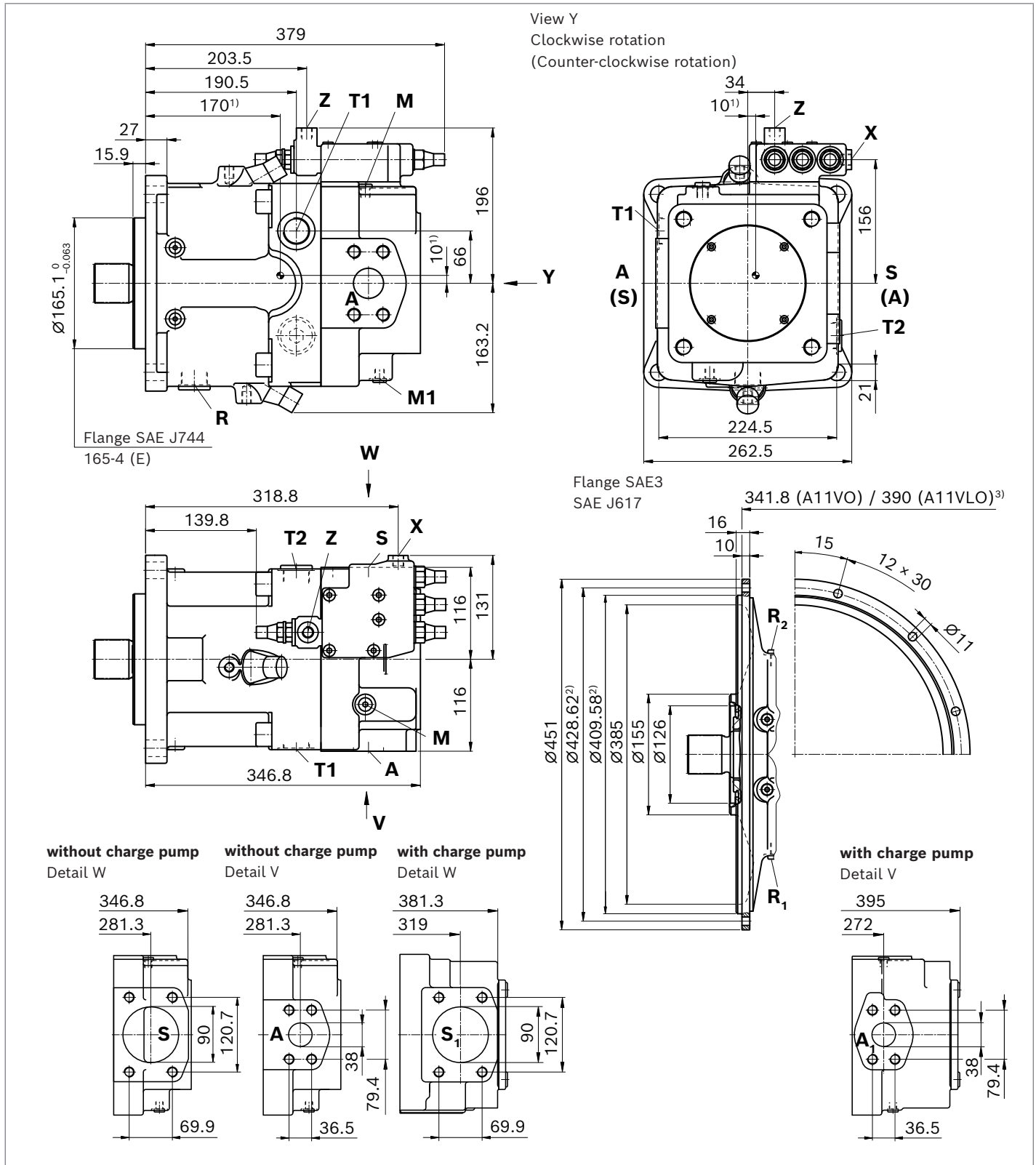

1) Center of gravity.

2) Dimensions according to SAE J617-No. 3, for connection to the flywheel housing of the combustion engine

3) The housing or length dimension with flange SAE J617-No.3 is 5 mm shorter than the standard housing.

▼ **Splined shaft DIN 5480**

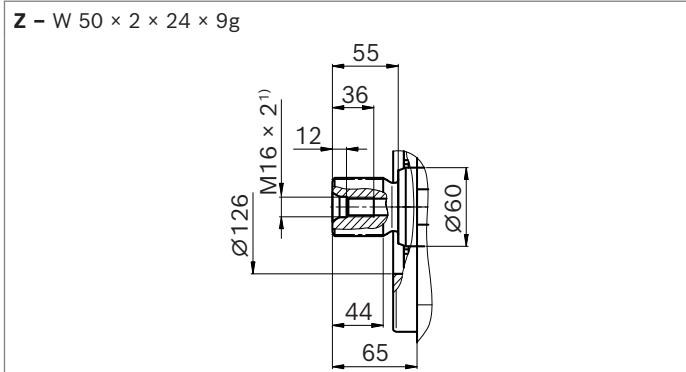

▼ **Parallel keyed shaft DIN 6885**

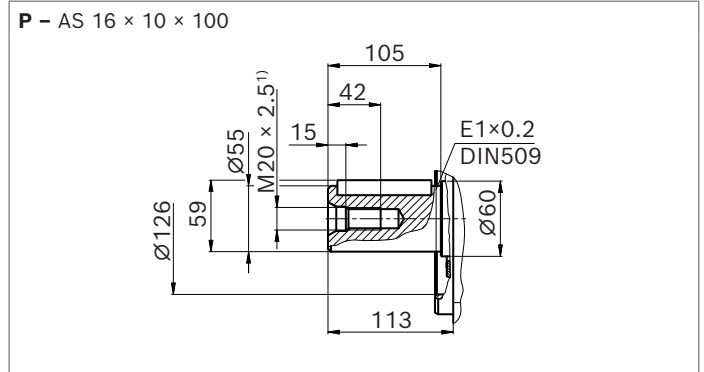

▼ **Splined shaft SAE J744**

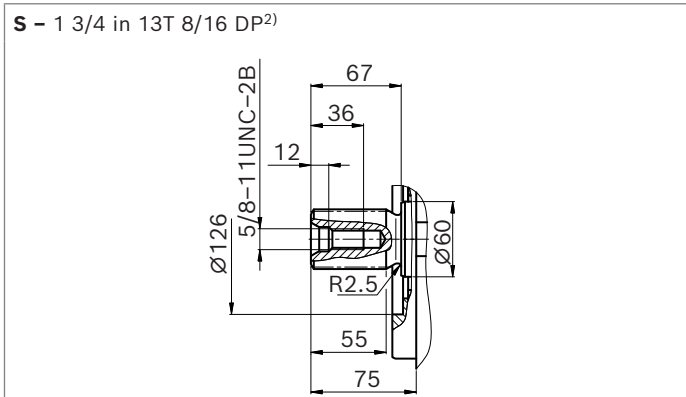

▼ **Splined shaft SAE J744**

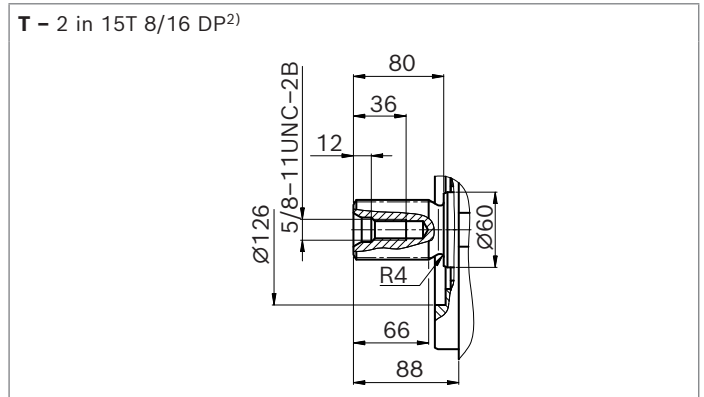

Ports	Standard	Size	p_{max} [bar] ³⁾	State ⁵⁾
A Working port Fastening thread	SAE J518 DIN 13	1 1/2 in M16 × 2; 21 deep	400	O
A₁ Working port Fastening thread	SAE J518 DIN 13	1 1/2 in M16 × 2; 21 deep	400	O
S Suction port (without charge pump) Fastening thread	SAE J518 DIN 13	3 1/2 in M16 × 2; 24 deep	30	O
S₁ Suction port (with charge pump) Fastening thread	SAE J518 DIN 13	3 1/2 in M16 × 2; 24 deep	2	O
T₁ Drain port	DIN 3852	M33 × 2; 16 deep	10	4)
T₂ Drain port	DIN 3852	M33 × 2; 16 deep	10	4)
R Air bleed port (flange SAE J744)	DIN 3852	M33 × 2; 16 deep	10	X
R₁ Air bleed port (flange SAE 3)	DIN 3852	M33 × 2; 16 deep	10	X
R₂ Air bleed port (flange SAE 3)	DIN 3852	M33 × 2; 16 deep	10	X
M₁ Measuring port control pressure	DIN 3852	M12 × 1.5; 12 deep	400	X
M Measuring port pressure A	DIN 3852	M12 × 1.5; 12 deep	400	X
X Pilot pressure port for version with load sensing (S) and remote-controlled pressure cut-off (G)	DIN 3852	M14 × 1.5; 12 deep	400	O
Y Pilot pressure port in version with stroke limiter (H...) and 2-stage pressure cut-off (E) and HD	DIN 3852	M14 × 1.5; 12 deep	40	O
Z Pilot pressure port for version with cross sensing (C) and power override (LR3) Power override (LG1) Load sensing override (S5)	DIN 3852	M14 × 1.5; 12 deep M16 × 1.5; 12 deep M14 × 1.5; 12 deep M14 × 1.5; 12 deep	400 40 40 30	O
G Control pressure (controller) for version with stroke limiter (H..., U2, U6), HP and EP	DIN 3852	M14 × 1.5; 12 deep	40	O

1) Center bore according to DIN 332 (thread according to DIN 13)
2) ANSI B92.1a-1976, 30° pressure angle, flat root, side fit, tolerance class 5
3) Dependent on settings and working pressure

4) Depending on installation position, **T₁** or **T₂** must be connected (see also installation instructions on pages 70 to 73)
5) O = Must be connected (plugged on delivery)
X = Plugged (in normal operation)

▼ **LRDH1 – Power controller, pressure cut-off, hydraulic stroke limiter (negative control)**

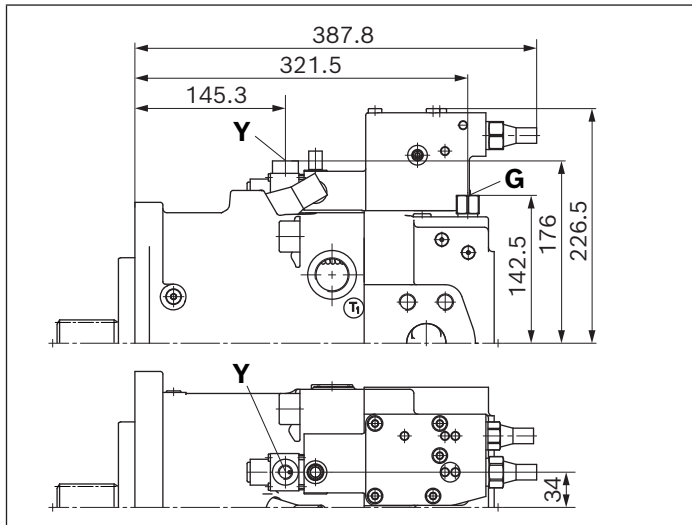

▼ **LRDH2 – Power controller, pressure cut-off, hydraulic stroke limiter (positive control)**

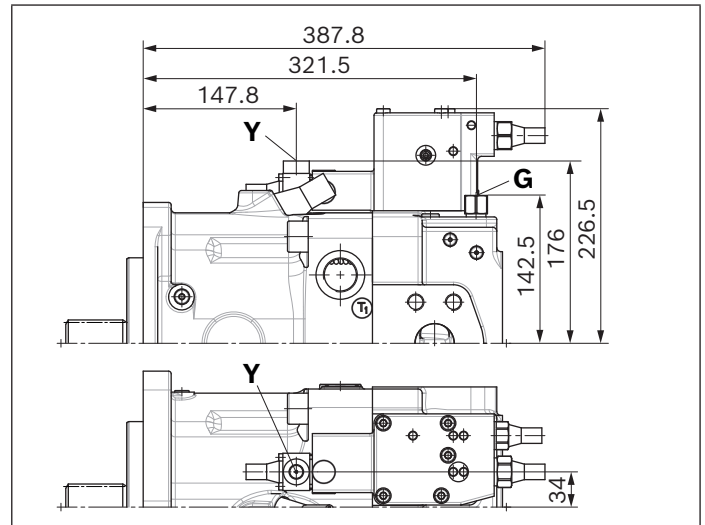

▼ **LRDU2 – Power controller, pressure cut-off, hydraulic stroke limiter (positive control)**

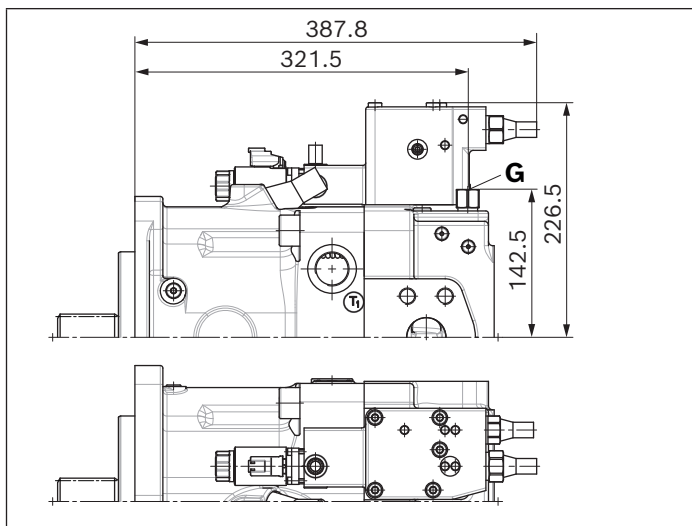

▼ **LR3DS – Power controller, high-pressure-dependent override, pressure cut-off, load sensing**

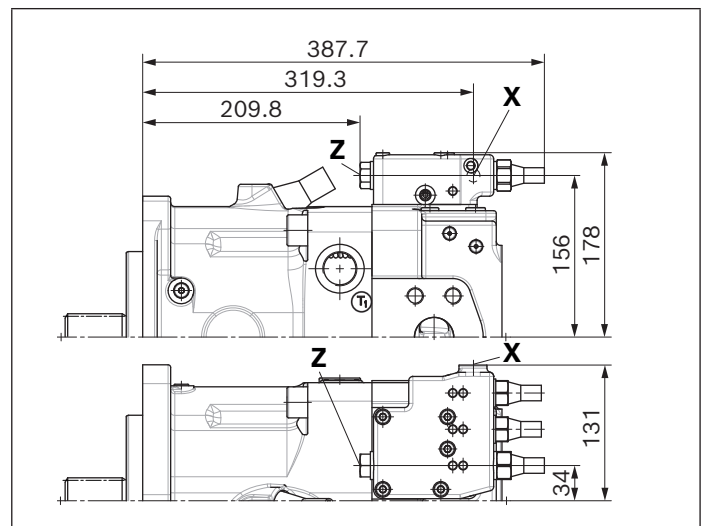

▼ **LG1GH2 – Power controller, pilot-pressure related override, stroke control**

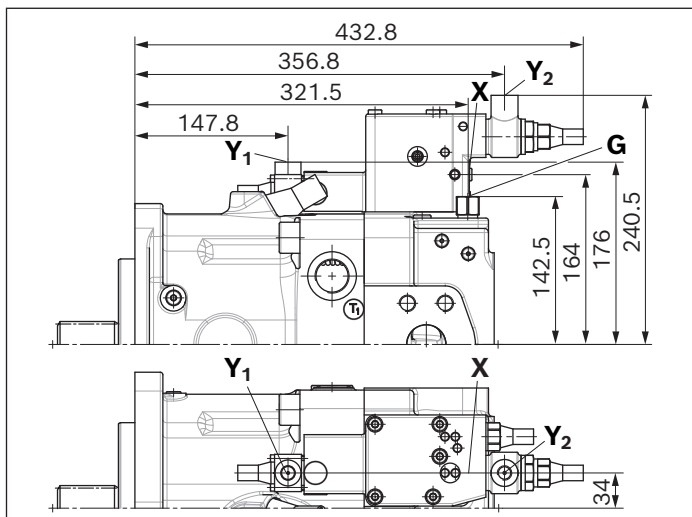

▼ **LG2H2 – Power controller, pilot-pressure related override**

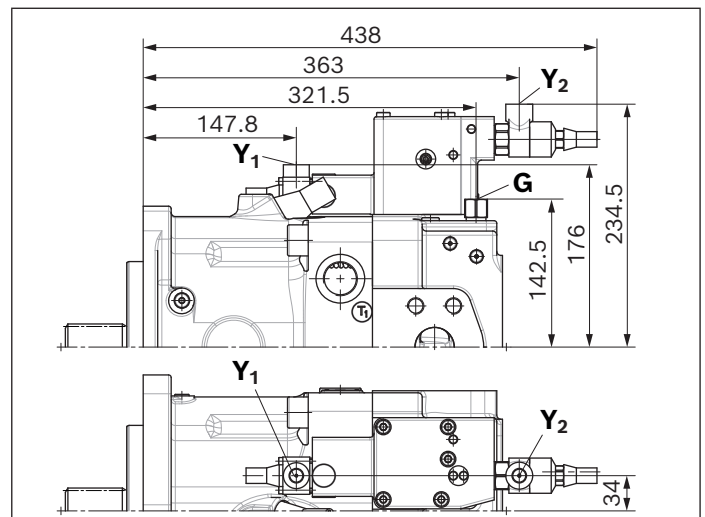

▼ **HD2D – Hydraulic, pilot-pressure related control, pressure cut-off**

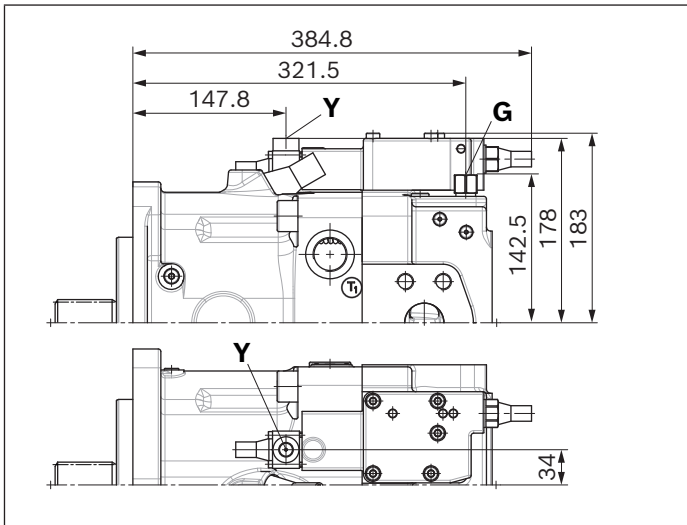

▼ **EP2D – Electric control, proportional solenoid, pressure cut-off**

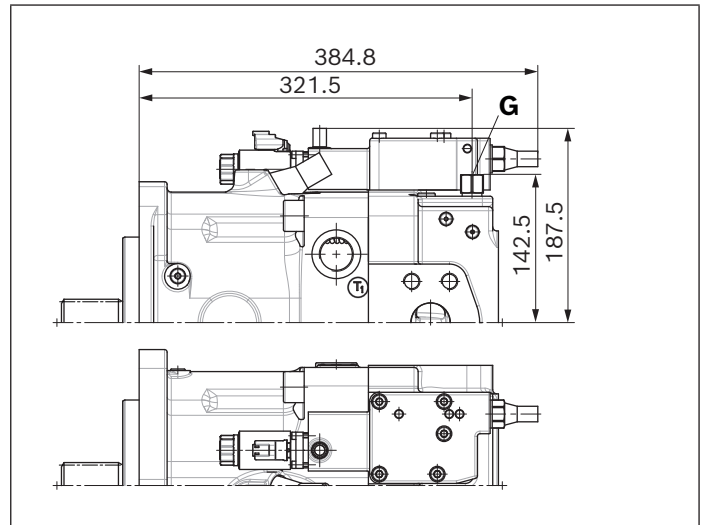

▼ **EP2G2 – Electric control with electrically overridable pressure cut-off (positive control)**

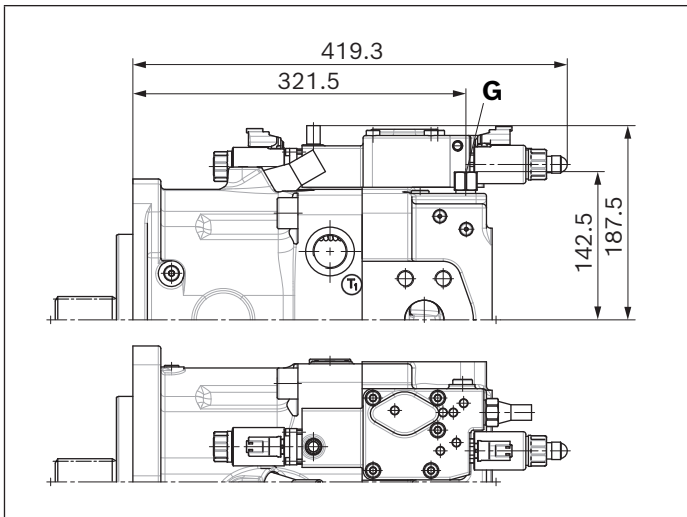

▼ **DRS/DRG – Remote-controlled pressure controller, load sensing**

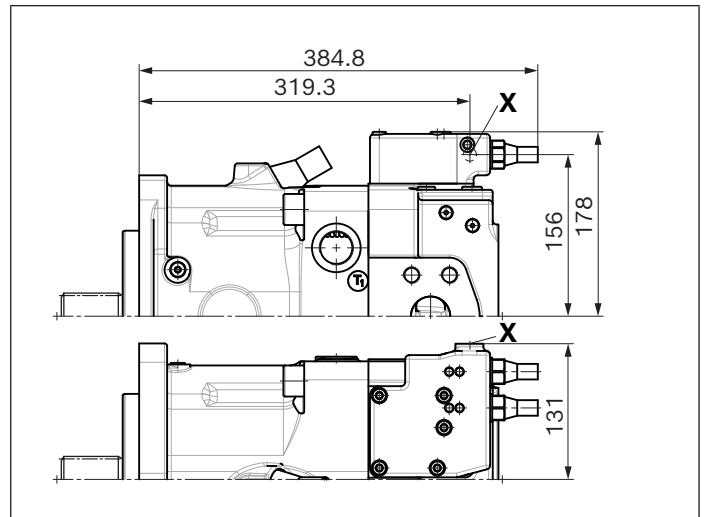

▼ **DRL – Pressure controller, parallel operation**

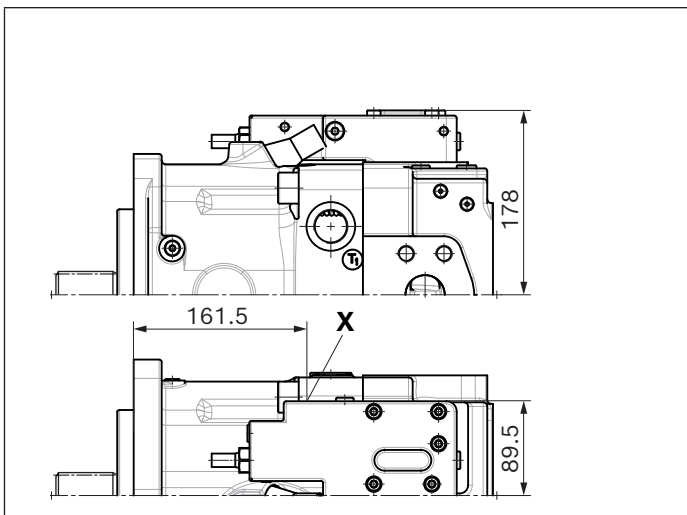

▼ **LE2S – Power controller, electrical override, load sensing (negative control)**

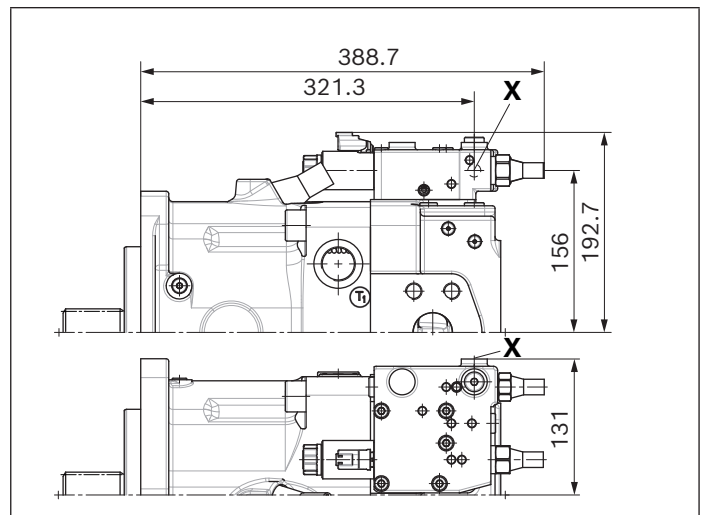

▼ **LE2S2/LE2S5 - Power controller, electrical override,
load sensing, overridable**

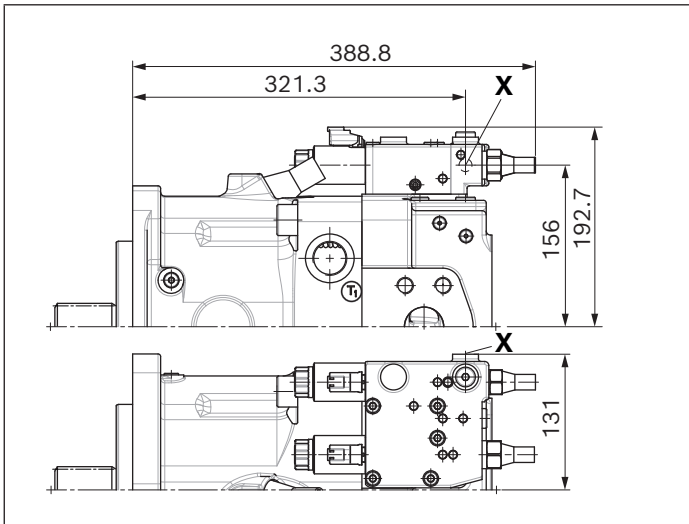

Dimensions, size 260

LRDCS – Power controller with pressure cut-off, cross-sensing and load sensing

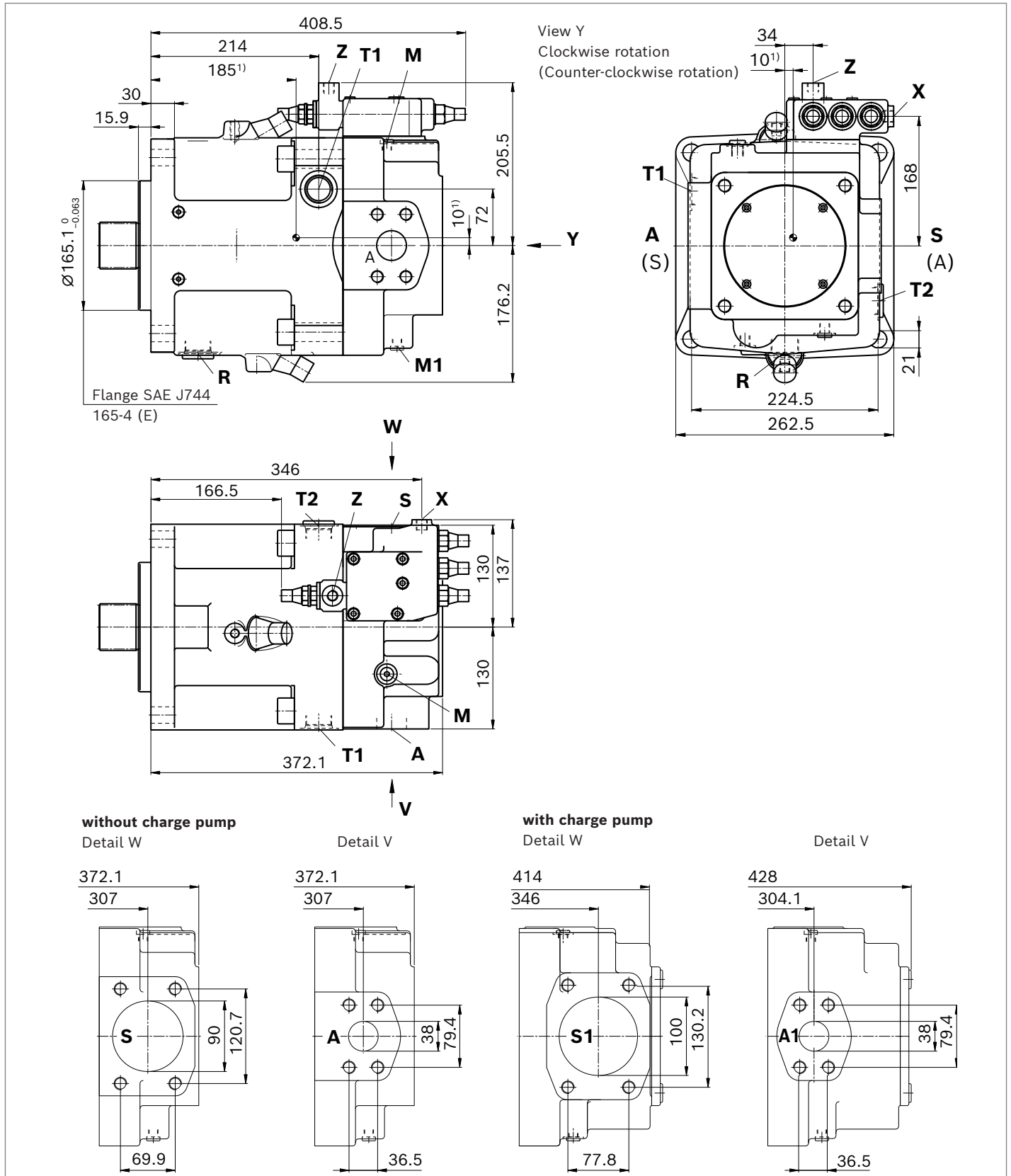

1) Center of gravity.

▼ **Splined shaft DIN 5480**

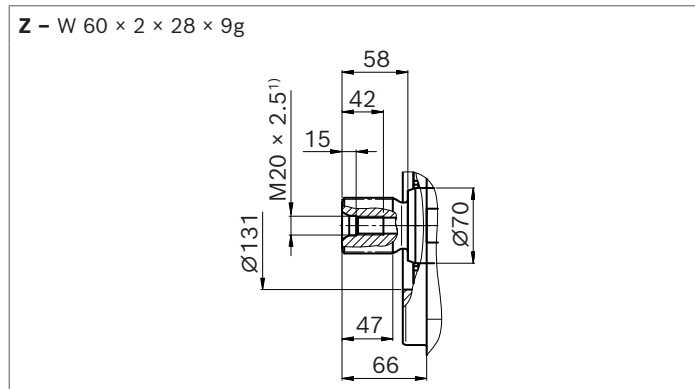

▼ **Parallel keyed shaft DIN 6885**

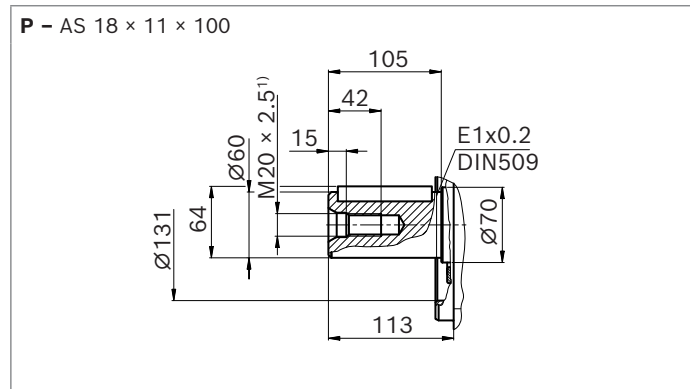

▼ **Splined shaft SAE J744**

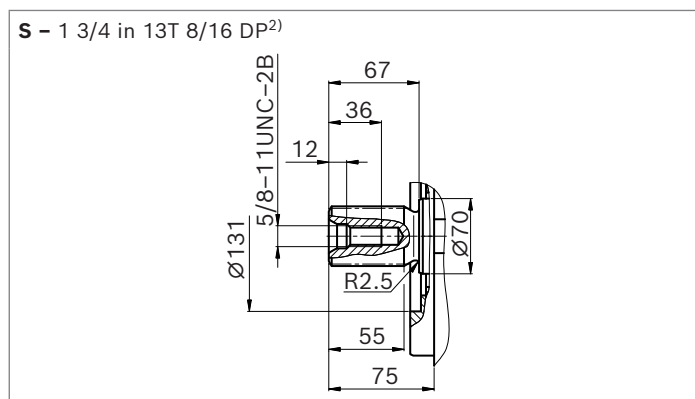

▼ **Splined shaft SAE J744**

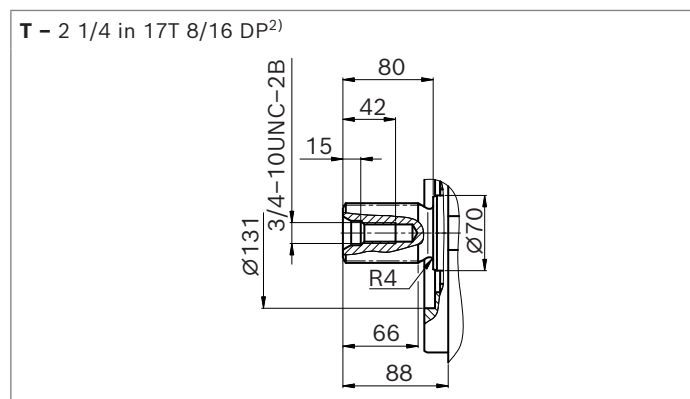

Ports	Standard	Size	p_{max} [bar] ³⁾	State ⁵⁾
A	SAE J518 DIN 13	1 1/2 in M16 × 2; 21 deep	400	O
A₁	SAE J518 DIN 13	1 1/2 in M16 × 2; 21 deep	400	O
S	SAE J518 DIN 13	3 1/2 in M16 × 2; 24 deep	30	O
S₁	SAE J518 DIN 13	4 in M16 × 2; 21 deep	2	O
T₁	DIN 3852	M33 × 2; 19 deep	10	4)
T₂	DIN 3852	M33 × 2; 19 deep	10	4)
R	DIN 3852	M33 × 2; 16 deep	10	X
M₁	DIN 3852	M12 × 1.5; 12 deep	400	X
M	DIN 3852	M12 × 1.5; 12 deep	400	X
X	DIN 3852	M14 × 1.5; 12 deep	400	O
Y	DIN 3852	M14 × 1.5; 12 deep	40	O
Z	DIN 3852	M14 × 1.5; 12 deep M16 × 1.5; 12 deep M14 × 1.5; 12 deep M14 × 1.5; 12 deep	400 40 30	O
G	DIN 3852	M14 × 1.5; 12 deep	40	O

1) Center bore according to DIN 332 (thread according to DIN 13)

2) ANSI B92.1a-1976, 30° pressure angle, flat root, side fit, tolerance class 5

3) Dependent on settings and working pressure

4) Depending on installation position, **T₁** or **T₂** must be connected (see also installation instructions on pages 70 to 73)

5) O = Must be connected (plugged on delivery)

X = Plugged (in normal operation)

▼ **LRDH1 – Power controller, pressure cut-off, hydraulic stroke limiter (negative control)**

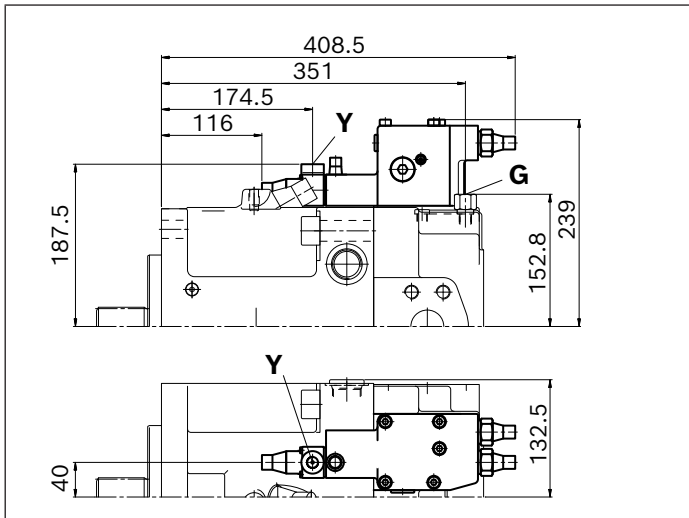

▼ **LRDH2 – Power controller, pressure cut-off, hydraulic stroke limiter (positive control)**

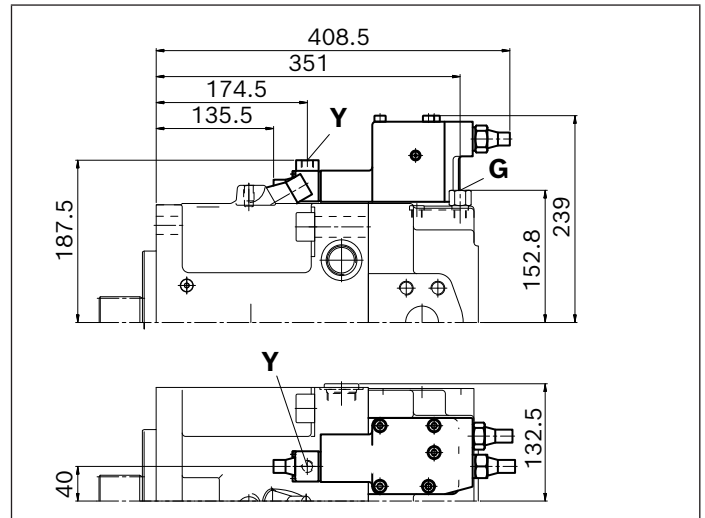

▼ **LRDU2 – Power controller, pressure cut-off, hydraulic stroke limiter (positive control)**

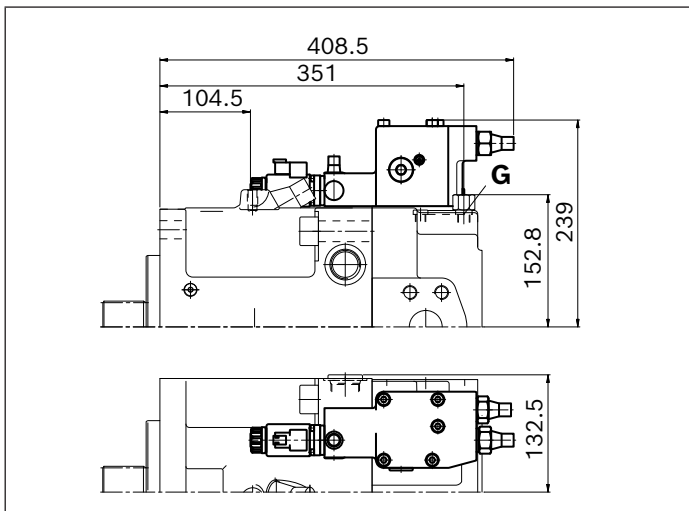

▼ **LR3DS – Power controller, high-pressure-dependent override, pressure cut-off, load sensing**

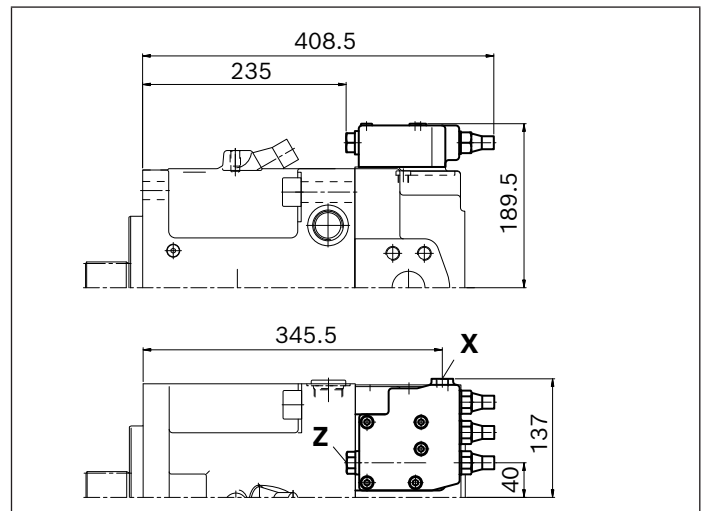

▼ **LG1GH2 – Power controller, pilot-pressure related override**

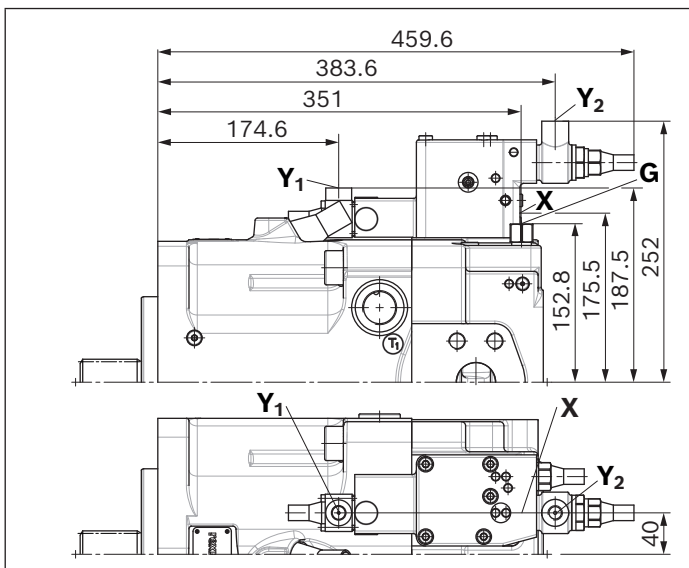

▼ **LG2H2 – Power controller, pilot-pressure related override**

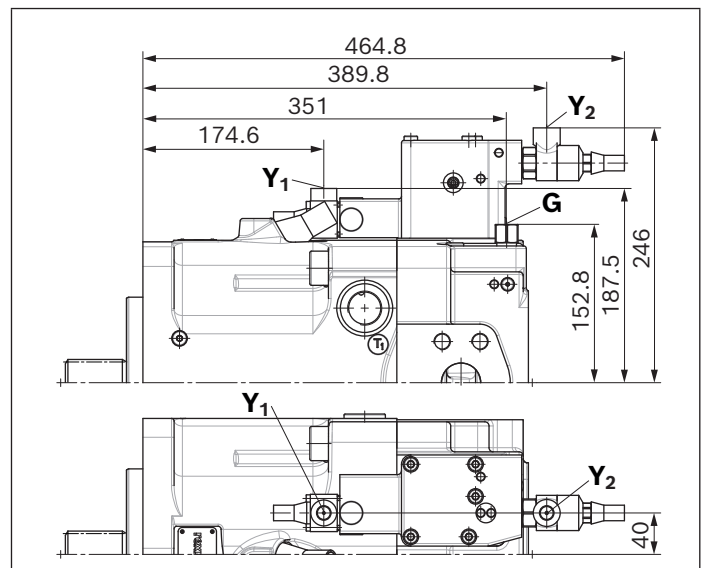

▼ **HD2D – Hydraulic, pilot-pressure related control, pressure cut-off**

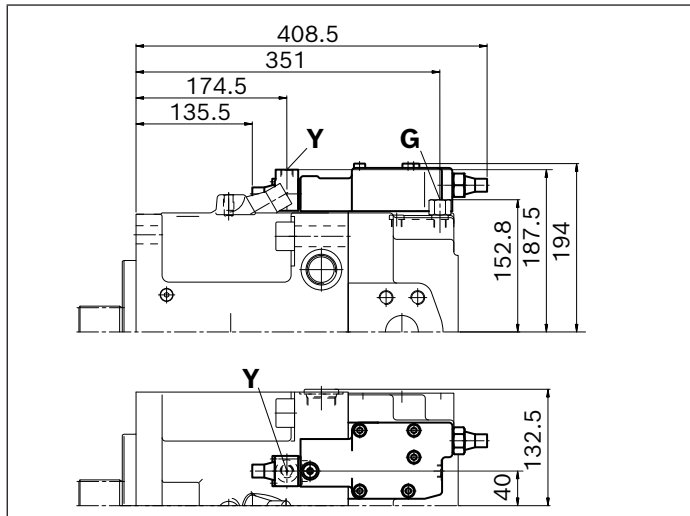

▼ **EP2D – Electric control, proportional solenoid, pressure cut-off**

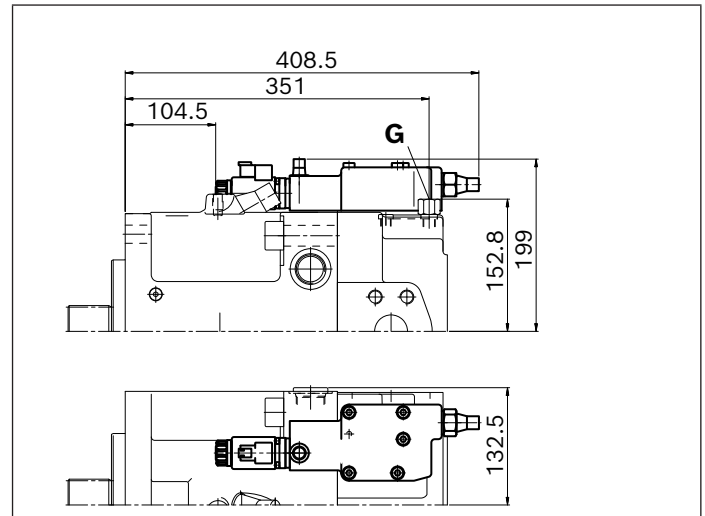

▼ **EP2G2/EP2G4 – Electric control with electrically overridable pressure cut-off (positive/negative control)**

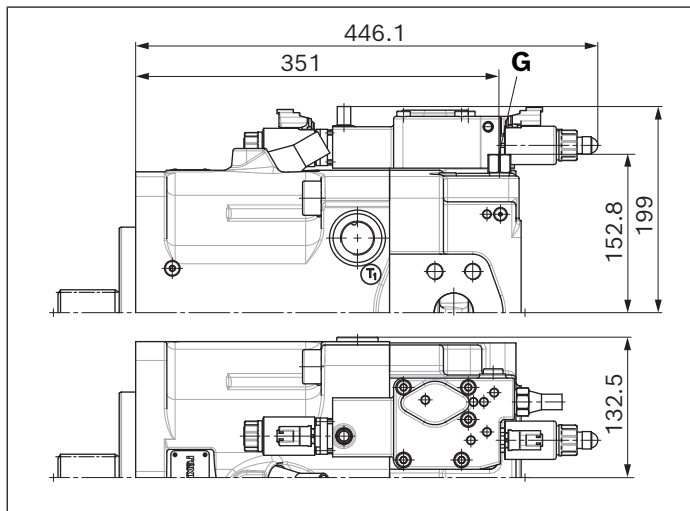

▼ **DRS/DRG – Remote-controlled pressure controller, load sensing**

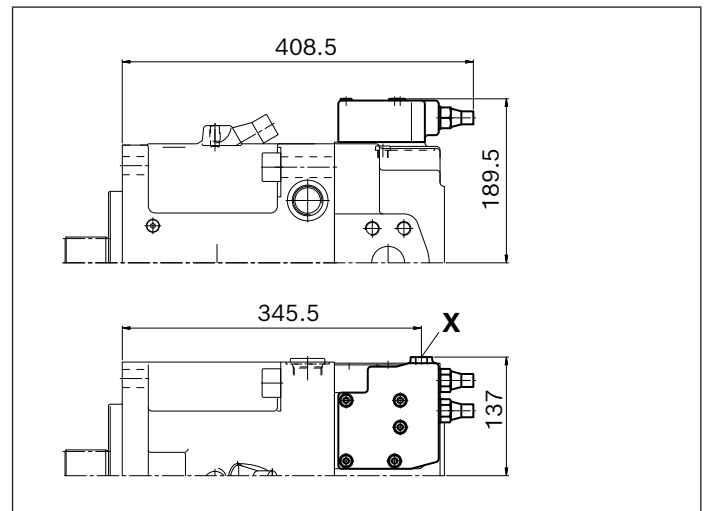

▼ **DRL – Pressure controller, parallel operation**

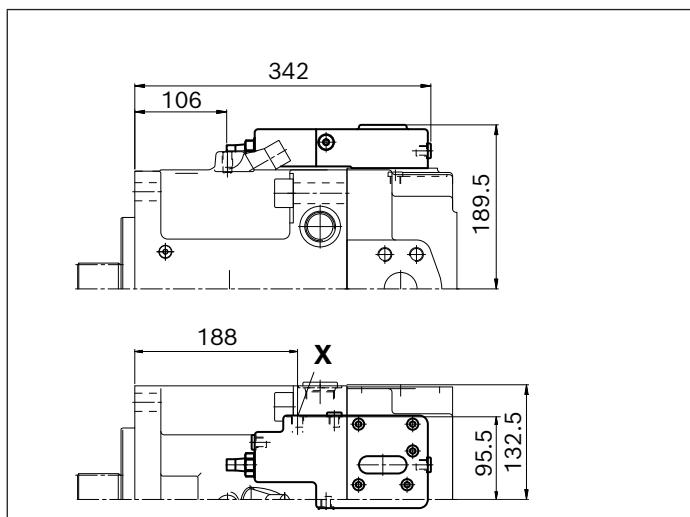

▼ **LE2S – Power controller, electrical override, load sensing (negative control)**

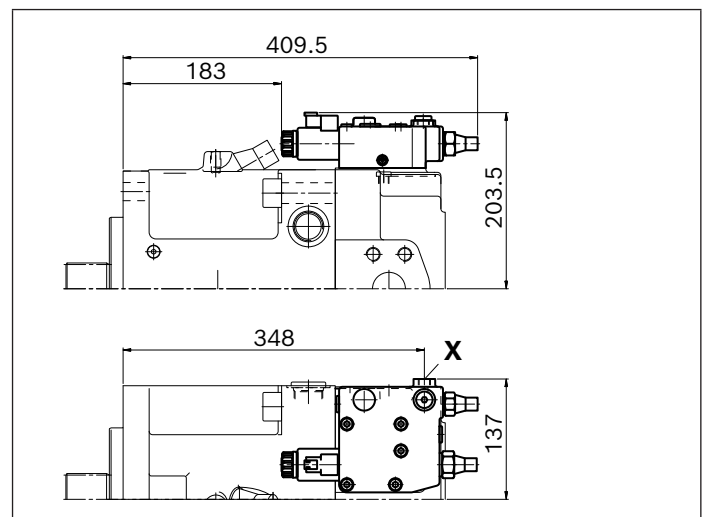

▼ **LE2S2/LE2S5 - Power controller, electrical override,
load sensing, overridable**

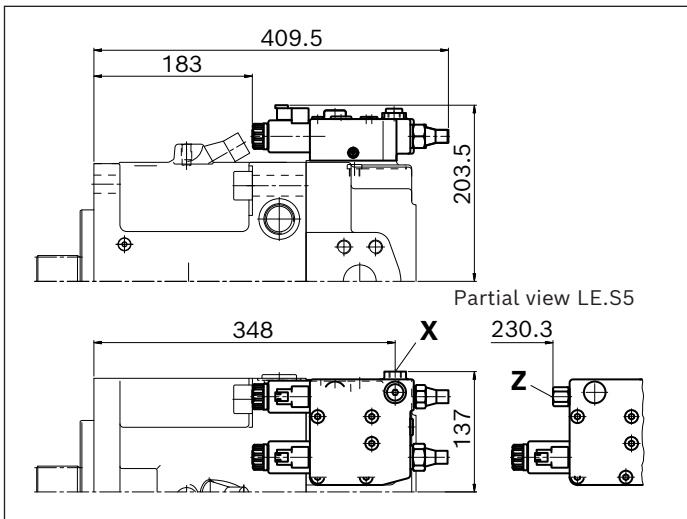

Dimensions, through-drive

Flange SAE J744 Diameter	Hub for splined shaft ¹⁾		Availability across sizes							Code ³⁾	
	Diameter		40	60	75	95	130/145	130/145 ²⁾	190		260
82-2 (A)	5/8 in	9T 16/32 DP ¹⁾	●	●	●	●	●	●	●	●	K01
	3/4 in	11T 16/32 DP ¹⁾	●	●	●	●	●	●	●	●	K52
101-2 (B)	7/8 in	13T 16/32 DP ¹⁾	●	●	●	●	●	●	●	●	K02
	1 in	15T 16/32 DP ¹⁾	●	●	●	●	●	●	●	●	K04
	W 35 × 2 × 16 × 9g		●	●	●	●	○	○	●	●	K79

● = Available ○ = On request

▼ 82-2 (A)

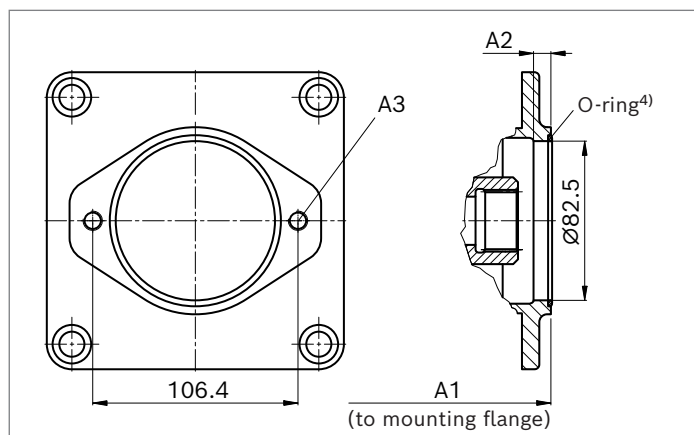

NG	A1		A2	A3 ⁵⁾
	K01	K52		
40	240	240	8	M10 × 1.5; 15 deep
60	257	257	-	M10 × 1.5; 15 deep
75	275	275	-	M10 × 1.5; 15 deep
95	306	306	-	M10 × 1.5; 12.5 deep
130/145	329	329	-	M10 × 1.5; 12.5 deep
130/145 ²⁾	363	363	-	M10 × 1.5; 12.5 deep
190	359.8	359.8	-	M10 × 1.5; 13 deep
190 ²⁾	394.3	394.3	-	M10 × 1.5; 13 deep
260	385.1	385.1	-	M10 × 1.5; 13 deep
260 ²⁾	4271)	4271)	-	M10 × 1.5; 13 deep

▼ 101-2 (B) size 40 ... 145

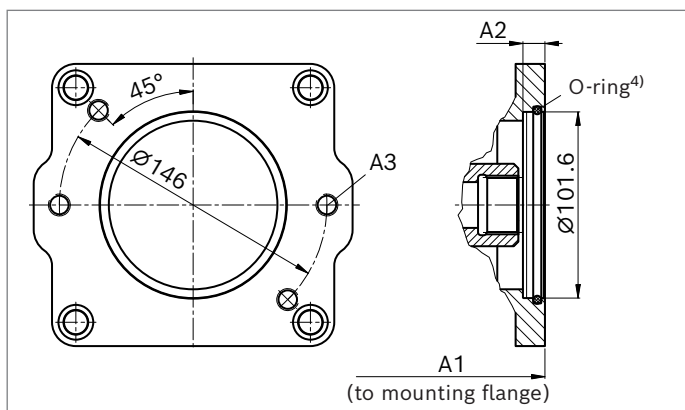

▼ 101-2 (B) size 190 ... 260

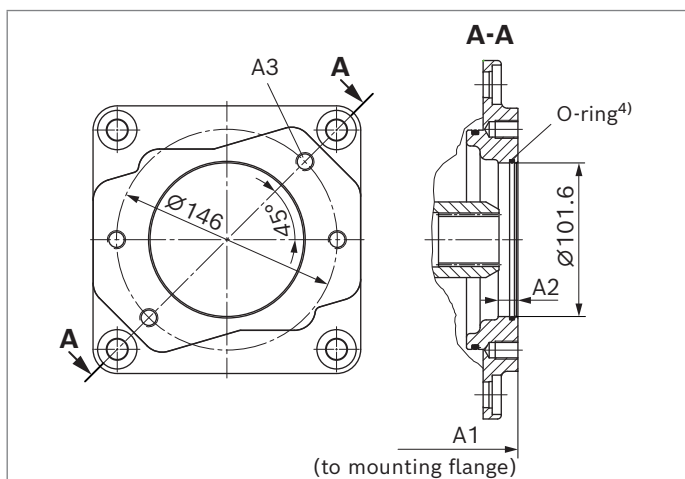

NG	A1			A2	A3 ⁵⁾
	K02	K04	K79		
40	244	244	249	10	M12 × 1.75; 19 deep
60	261	261	265	10	M12 × 1.75; 19 deep
75	279	279	283	10	M12 × 1.75; 19 deep
95	303	303	303	10	M12 × 1.75; 16 deep
130/145	326	326	326	10	M12 × 1.75; 16 deep
130/145 ²⁾	360	360	-	10	M12 × 1.75; 16 deep
190	369.8	369.8	369.8	-	M12 × 1.75; 15 deep
190 ²⁾	404.3	404.3	404.3	-	M12 × 1.75; 15 deep
260	395.1	395.1	395.1	-	M12 × 1.75; 15 deep
260 ²⁾	437.1	437.1	437.1	-	M12 × 1.75; 15 deep

- 1) According to ANSI B92.1a, 30° pressure angle, flat root, side fit, tolerance class 5
- 2) Version with charge pump
- 3) The through-drive can be rotated by 90°. Standard position as shown (version 0°). Please specify in plain text whether version 90° is used.
- 4) O-ring included in the scope of delivery
- 5) Thread according to DIN 13.

Flange SAE J744 Diameter	Hub for splined shaft ¹⁾ Diameter	Availability across sizes								Code ³⁾
		40	60	75	95	130/145	130/145 ²⁾	190	260	
127-2 (C)	1 1/4 in 14T 12/24 DP ¹⁾	-	●	●	●	●	●	-	-	K07
	1 1/2 in 17T 12/24 DP ¹⁾	-	-	-	●	●	●	-	-	K24
	W 30 × 2 × 14 × 9g	-	●	●	●	●	-	-	-	K80
	W 35 × 2 × 16 × 9g	-	●	●	●	●	●	-	-	K61
127-2+4 (C)	1 1/4 in 14T 12/24 DP ¹⁾	-	-	-	-	-	-	●	●	K07
	1 1/2 in 17T 12/24 DP ¹⁾	-	-	-	-	-	-	●	●	K24
	W 30 × 2 × 14 × 9g	-	-	-	-	-	-	●	●	K80
	W 35 × 2 × 16 × 9g	-	-	-	-	-	-	●	●	K61

● = Available ○ = On request - = Not available

▼ 127-2 (C)

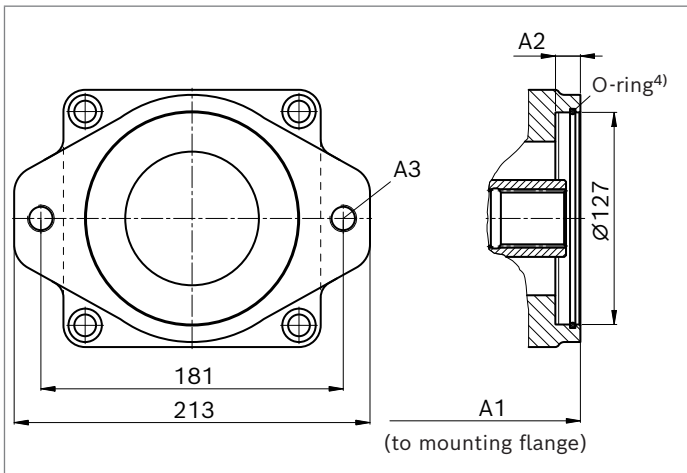

NG	A1				A2	A3 ⁵⁾
	K07	K24	K80	K61		
60	272	-	265	265	13	M16 × 2; 20 deep
75	290	-	290	290	13	M16 × 2; 20 deep
95	318	318	318	318	13	M16 × 2; 16 deep
130/145	330	341	330	330	13	M16 × 2; 20 deep
130/145 ²⁾	364	375	364	364	13	M16 × 2; 20 deep

▼ 127-2+4 (C)

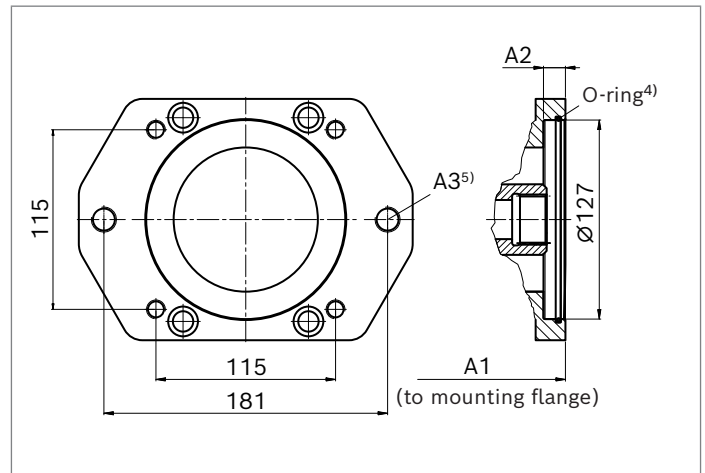

NG	A1				A2	A3 ⁵⁾
	K07	K24	K80	K61		
190	365.8	367.8	367.8	367.8	13	M16 × 2; 19 deep
190 ²⁾	400.3	402.3	400	400	13	M16 × 2; 19 deep
260	391.1	391.1	391.1	391.1	13	M16 × 2; 19 deep
260 ²⁾	433.1	433.1	433.1	433.1	13	M16 × 2; 19 deep

1) According to ANSI B92.1a, 30° pressure angle, flat root, side fit, tolerance class 5
 2) Version with charge pump
 3) The through-drive can be rotated by 90°. Standard position as shown (version 0°). Please specify in plain text whether version 90° is used.

4) O-ring included in the scope of delivery
 5) Thread according to DIN 13.

Flange SAE J744	Hub for splined shaft ¹⁾	Availability across sizes								Code ³⁾
		40	60	75	95	130/145	130/145 ²⁾	190	260	
152-4 (D)	1 1/4in 14T 12/24DP	-	-	●	●	●	●	●	●	K86
	1 3/4 in 13T 8/16 DP ¹⁾	-	-	-	-	●	●	●	●	K17
	W 40 × 2 × 18 × 9g	-	-	●	●	●	●	●	●	K81
	W 45 × 2 × 21 × 9g	-	-	-	●	●	●	●	●	K82
	W 50 × 2 × 24 × 9g	-	-	-	-	●	●	●	●	K83
165-4 (E)	1 3/4 in 13T 16/32 DP ¹⁾	-	-	-	-	-	-	●	●	K72
	W 50 × 2 × 24 × 9g	-	-	-	-	-	-	●	●	K84
	W 60 × 2 × 28 × 9g	-	-	-	-	-	-	-	●	K67

● = Available ○ = On request - = Not available

▼ **152-4 (D)**

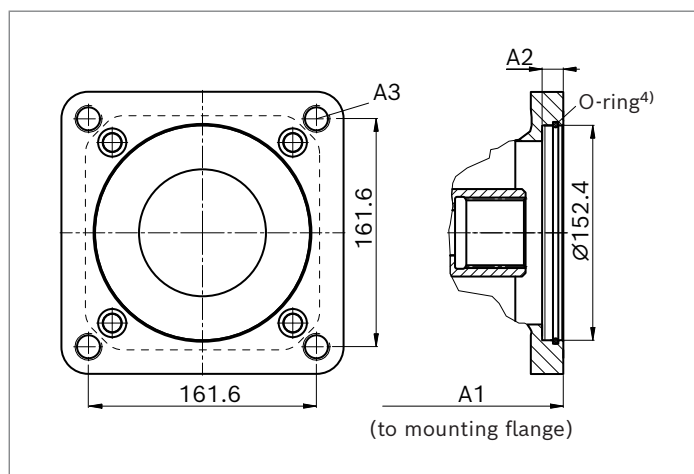

NG	A1					A2	A3 ⁵⁾
	K86	K17	K81	K82	K83		
75	290	-	290	-	-	13	M20 × 2.5; 28 deep
95	317	327	317	317	-	30	M20 × 2.5; 25 deep
130/ 145	340	350	340	340	340	13	M20 × 2.5; 25 deep
130/ 145 ²⁾	374	383	374	374	374	13	M20 × 2.5; 25 deep
190	392	391.8	391.8	392	391.8	13	M20 × 2.5; 22 deep
190 ²⁾	424	426.3	426.3	424	426.3	13	M20 × 2.5; 22 deep
260	417	417.1	417.1	417	417.1	13	M20 × 2.5; 22 deep
260 ²⁾	459	459.1	459.1	459	459.1	13	M20 × 2.5; 22 deep

▼ **165-4 (E)**

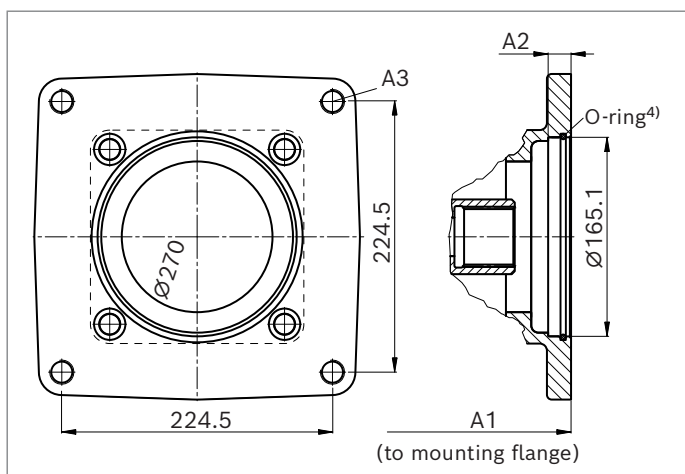

NG	A1			A2	A3 ⁵⁾
	K72	K84	K67		
190	389.8	374.8	-	19	M20 × 2.5; 26 deep
190 ²⁾	424.3	409.3	-	19	M20 × 2.5; 20 deep
260	415.1	400.1	400.1	19	M20 × 2.5; 20 deep
260 ²⁾	457.1	442.1	442.1	19	M20 × 2.5; 20 deep

1) According to ANSI B92.1a, 30° pressure angle, flat root, side fit, tolerance class 5
 2) Version with charge pump
 3) Mounting holes pattern viewed on through-drive with control at top

4) O-ring included in the scope of delivery
 5) Thread according to DIN 13.

Overview of mounting options

Through-drive			Mounting options – 2nd pump			
Flange	Hub for splined shaft	Code	A11VO/10 NG (shaft)	A10V(S)O/31 NG (shaft)	A10V(S)O/53 NG (shaft)	A4VG/32 NG (shaft)
82-2 (A)	5/8 in	K01	–	18 (U)	10 (U)	–
	3/4 in	K52	–	18 (S)	10 (S)	–
101-2 (B)	7/8 in	K02	–	28 (S), 45 (U)	28 (S), 45 (U)	–
	1 in	K04	40 (S)	45 (S)	45 (S), 60 (U)	28 (S)
	W35	K79	40 (Z)	–	–	–
127-2/-4 (C)	1 1/4 in	K07	60 (S)	71 (S), 100 (U)	60 (S) ¹⁾ , 85 (U)	40, 56, 71 (S)
	1 1/2 in	K24	–	100 (S)	85 (S)	–
	W30	K80	–	–	–	40, 56 (KXX)
	W35	K61	60 (Z)	–	–	40, 56 (A), 71 (Z)
152-4 (D)	1 1/4 in	K86	95, 130, 145 (S)	–	–	90, 125 (S)
	1 3/4 in	K17	95, 130, 145 (S)	–	–	90, 125 (S)
	W40	K81	75 (Z)	–	–	125 (Z)
	W45	K82	95 (Z)	–	–	–
	W50	K83	130, 145 (Z)	–	–	–
165-4 (E)	1 3/4 in	K72	190, 260 (S)	–	–	–
	W50	K84	190 (Z)	–	–	–
	W60	K67	260 (Z)	–	–	–

Through-drive			Mounting options – 2nd pump		
Flange	Hub for splined shaft	Code	A4VG/40 NG (shaft)	A10VG NG (shaft)	External gear pump ²⁾
82-2 (A)	5/8 in	K01	–	–	AZPF, AZPS NG4 ... 28, AZPW NG5 ... 22
	3/4 in	K52	–	–	AZPF NG4 ... 28
101-2 (B)	7/8 in	K02	–	18 (S)	AZPN-11 NG20 ... 25, AZPG-22 NG28 ... 100
	1 in	K04	–	28, 45 (S)	–
	W35	K79	–	–	–
127-2/-4 (C)	1 1/4 in	K07	–	63 (S)	–
	1 1/2 in	K24	–	–	–
	W30	K80	–	–	–
	W35	K61	–	–	–
152-4 (D)	1 1/4 in	K86	110, 125, 145, 175 (T1)	–	–
	1 3/4 in	K17	110, 125, 145, 175 (T1)	–	–
	W40	K81	–	–	–
	W45	K82	–	–	–
	W50	K83	–	–	–
165-4 (E)	1 3/4 in	K72	175 (T1)	–	–
	W50	K84	–	–	–
	W60	K67	–	–	–

1) A10VO with 4-hole flange can only be mounted on A11V(L)O 190 and 260.

2) Bosch Rexroth recommends special versions of the external gear pumps. Please contact us.

Combination pumps A11V(L)O + A11V(L)O

Total length A¹⁾

A11VO (1st pump)	A11VO (2nd pump)							A11VLO (2nd pump)		
	NG40	NG60	NG75	NG95	NG130/145	NG190	NG260	NG130/145	NG190	NG260
NG40	-	-	-	-	-	-	-	-	-	-
NG60	490	507	-	-	-	-	-	-	-	-
NG75	-	525	550	-	-	-	-	-	-	-
NG95	528	560	577	604	-	-	-	-	-	-
NG130/145	551	572	600	627	650	-	-	698	-	-
NG190	586.8	609.8	652	679	702	723.6	-	750	772.3	-
NG260	620	633.5	677	704	727	746.8	772	775	795.5	828

A11VLO (1st pump)	A11VO (2nd pump)							A11VLO (2nd pump)		
	NG40	NG60	NG75	NG95	NG130/145	NG190	NG260	NG130/145	NG190	NG260
NG130/145	585	606	634	661	684	-	-	732	-	-
NG190	619	642	684	711	734	755.8	-	782	804.5	-
NG260	662.5	675.5	719	746	769	789.3	814.5	817	838	870.5

By using combination pumps, it is possible to have independent circuits without the need for splitter gearboxes. When ordering combination pumps the type designations for the 1st and the 2nd pump must be joined by a "+".

Order example:

A11VO130LRDS/10R-NZD12K61+ A11VO60LRDS/10-NZC12N00

A tandem pump, with two pumps of equal size, is permissible without additional supports, assuming that the dynamic mass acceleration does not exceed maximum 10 g (= 98.1 m/s²).

For combination pumps consisting of more than two pumps, the mounting flange must be calculated for the permissible mass torque.

▼ Total length of a combination pump

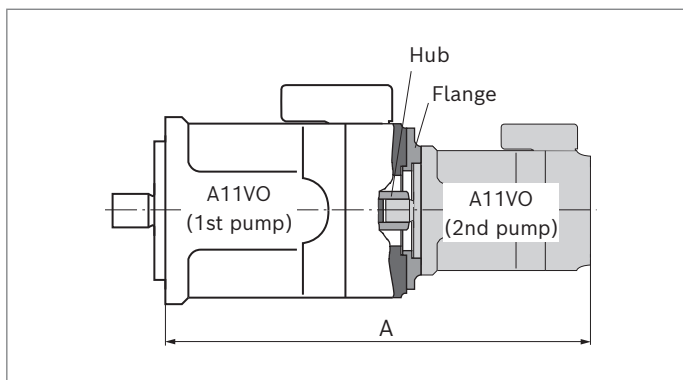

1) When using the Z-shaft (splined shaft DIN 5480) for the mounted pump (2nd pump)

Swivel angle indicator

Optical swivel angle indicator V

With the optical swivel angle indicator, the swivel position of the pump is indicated by a mechanical indicator on the side of the housing.

▼ Circuit diagram

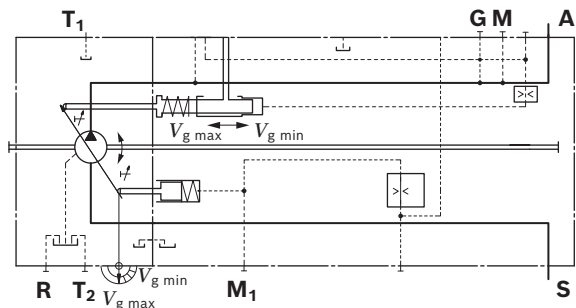

▼ Swivel angle indicator

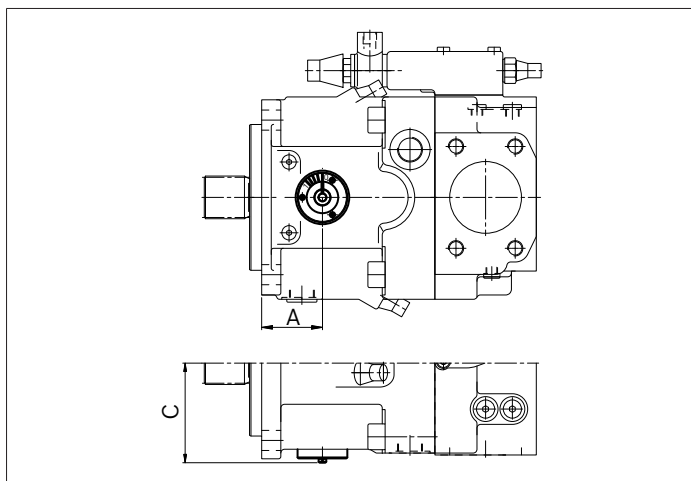

NG	A	C
40	50.5	84.0
60	not available	
75	60.7	97.0
95	63.5	104.0
130	70.9	112.0
190	87.6	123.5
260	87.6	137.0

Electric swivel angle sensor R

With electric swivel angle indicator, the pump swivel position is measured by an electric swivel angle sensor. It has a robust, sealed housing and an integrated electronics unit that has been developed for automotive applications.

As an output the Hall effect swivel angle sensor delivers a voltage signal proportional to the swivel angle.

▼ Circuit diagram

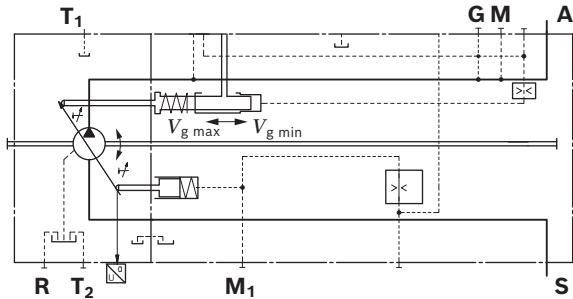

Characteristics	
Supply voltage U_b	10 ... 30 V DC
Output voltage U_a	2.5 V ($V_{g \min}$) 4.5 V ($V_{g \max}$)
Reverse polarity protection	Short circuit resistant
EMC resistance	Details on request
Operating temperature range	-40 ... +125 °C
Vibration resistance sinusoidal vibration EN 60068-2-6	10 g / 5 ... 2000 Hz
Shock resistance: continuous shock IEC 68-2-29	25 g
Salt spray resistance DIN50021-SS	96 h
Type of protection DIN/EN 60529	IP67 and IP69K
Housing material	Plastic

AMP Superseal mating connector

Consisting of		AMP designation
1 housing	3-pin	282087-1
3 seals	yellow	281934-2
3 sockets	1.8 - 3.3 mm	283025-1

The mating connector is not included in the scope of delivery.

This can be supplied by Bosch Rexroth on request (material number R902602132).

▼ Electric swivel angle sensor

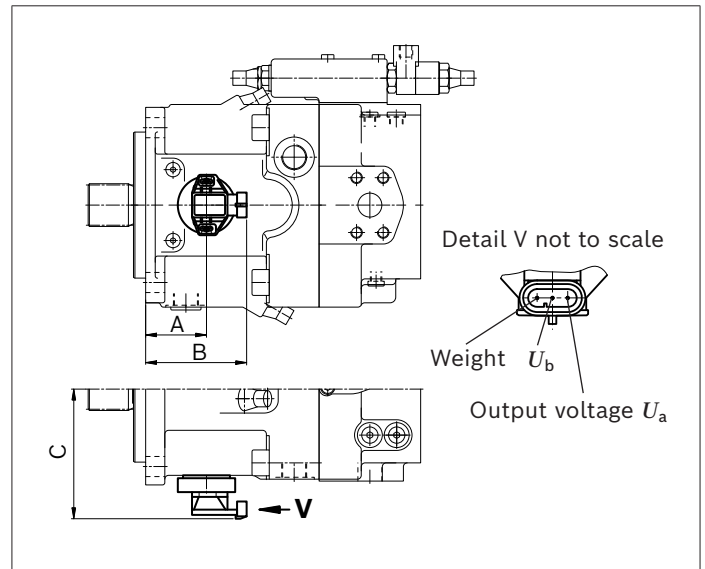

NG	A	B	C
40	50.5	88.5	118.3
60	not available		
75	60.7	98.7	131.3
95	63.5	101.5	138.3
130	70.9	108.9	146.3
190	87.6	125.6	157.8
260	87.6	125.6	171.3

Connector for solenoids

DEUTSCH DT04-2P-EP04

Molded, 2-pin, without bidirectional suppressor diode

The following type of protection ensues with the installed mating connector:

- ▶ IP67 (DIN/EN 60529) and
- ▶ IP69K (DIN 40050-9)

▼ Switching symbol

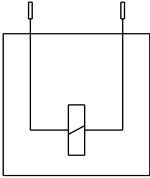

Mating connector DEUTSCH DT06-2S-EP04

Consisting of	DT designation
1 housing	DT06-2S-EP04
1 wedge	W2S
2 sockets	0462-201-16141

The mating connector is not included in the scope of delivery.

This can be supplied by Bosch Rexroth on request (material number R902601804).

Notice

- ▶ If necessary, you can change the position of the connector by turning the solenoid body.
- ▶ The procedure is defined in the instruction manual.
- ▶ Manual override can be used on the electric system in case of malfunction. Not permissible for continuous operation!

Installation instructions

General

The axial piston unit must be filled with hydraulic fluid and vented during commissioning and operation. This must also be observed during longer standstills, as the axial piston unit can empty itself via the hydraulic lines. Particularly in the installation position "drive shaft upwards", filling and air bleeding must be carried out completely as there is, for example, a danger of dry running.

The leakage in the housing area must be directed to the reservoir via the highest drain port (**T₁/T₂**).

For combination pumps, the leakage must be drained off at each single pump.

If a shared drain line is used for several units, make sure that the respective case pressure in each unit is not exceeded. The shared drain line must be dimensioned to ensure that the maximum permissible case pressure of all connected units is not exceeded in any operating condition, particularly at cold start. If this is not possible, separate drain line must be laid, if necessary.

To prevent the transmission of structure-borne noise, use elastic elements to decouple all connecting lines from all vibration-capable components (e.g. reservoir, frame parts).

Under all operating conditions, the suction line and drain line must flow into the reservoir below the minimum fluid level of the reservoir. The permissible suction height h_s results from the total pressure loss, but must not be higher than $h_{s\ max} = 800\ \text{mm}$. The minimum suction pressure at port **S** of 0.8 bar absolute (without charge pump) or 0.6 bar absolute (with charge pump) must not be fallen below during operation (*cold start 0.5 bar absolute*).

For the reservoir design, ensure that there is an adequate distance between the suction line and the drain line.

We recommend using a baffle (baffle plate) between suction line and drain line. A baffle improves the air separation ability as it gives the hydraulic fluid more time for desorption. Apart from that, this prevents the heated return flow from being drawn directly back into the suction line. The suction port must be supplied with air-free, calmed and cooled hydraulic fluid.

Installation position

See the following examples **1** to **10**.

Further installation positions are available upon request.

Recommended installation position: **1** and **2**

Key	
F₁/F₂	Filling / Air bleeding
S	Suction port
T₁/T₂	Drain port
SB	Baffle (baffle plate)
h_{t min}	Minimum required immersion depth (200 mm)
h_{min}	Minimum required distance to reservoir bottom (100 mm)
h_{ES min}	Minimum height required to prevent axial piston unit from draining (25 mm)
h_{S max}	Maximum permissible suction height (800 mm)

Notice

- ▶ In certain installation positions, an influence on the control or control can be expected. Gravity, dead weight and case pressure can cause minor characteristic shifts and changes in actuating time.
- ▶ Ports **F₁** and **F₂** are part of the external piping and must be provided on the customer side to make filling and air bleeding easier.

Below-reservoir installation (standard)

Below-reservoir installation means that the axial piston unit is installed outside of the reservoir below the minimum fluid level.

▼ **Installation position 1**

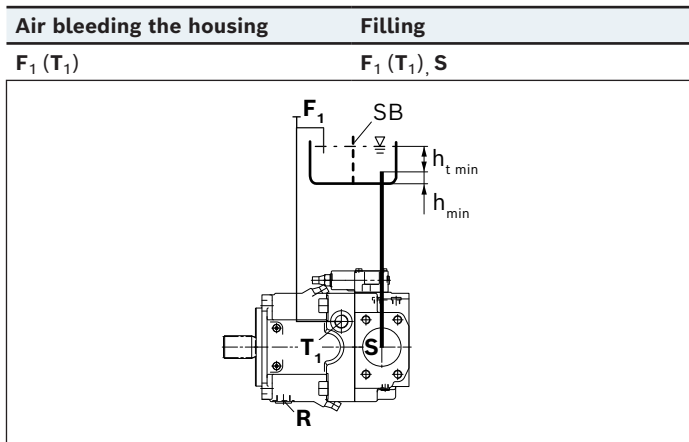

▼ **Installation position 2**

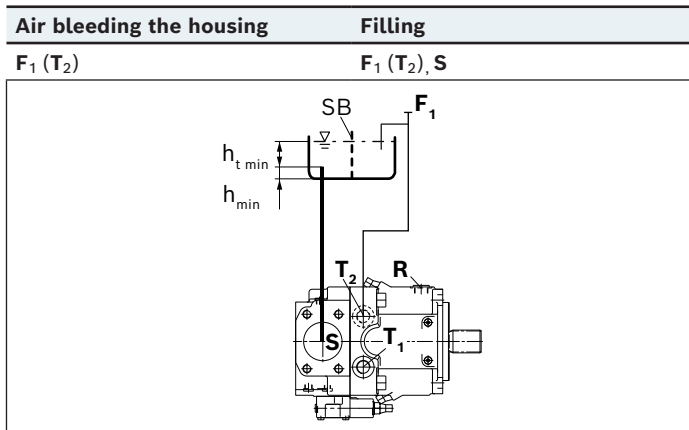

▼ **Installation position 3**

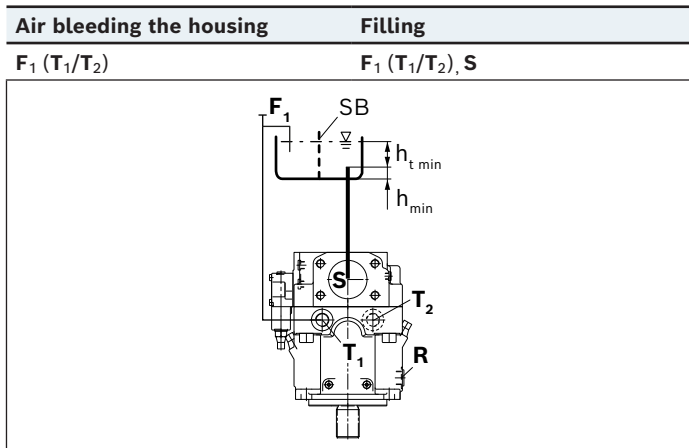

▼ **Installation position 4**

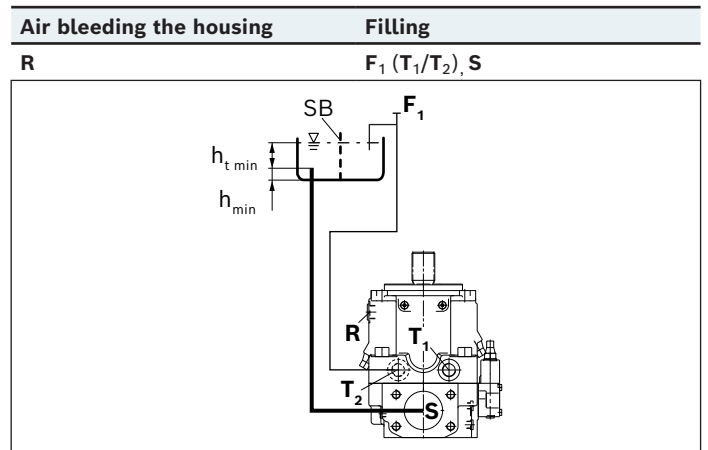

For key, see page 70.

Above-reservoir installation

Above-reservoir installation means that the axial piston unit is installed above the minimum fluid level of the reservoir. To prevent the axial piston unit from draining, a height difference $h_{ES\ min}$ of at least 25mm at port **R** is required in position 7.

The version A11VLO (with charge pump) is not intended for above-reservoir installation.

Recommendation for installation position **7** (shaft upward):

A check valve in the drain line (cracking pressure 0.5 bar) can prevent draining of the housing area. For control options with pressure controllers, stroke limiters, HD and EP control, the minimum displacement setting must be $V_g \geq 5\% V_{g\ max}$.

Observe the maximum permissible suction height $h_{S\ max} = 800\ mm$.

Installation position 5

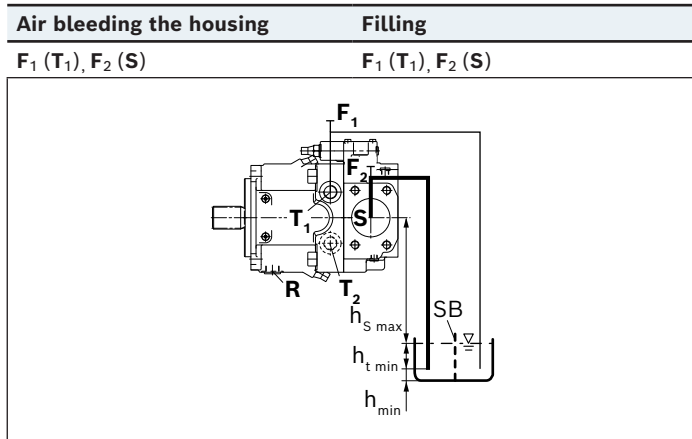

Installation position 6

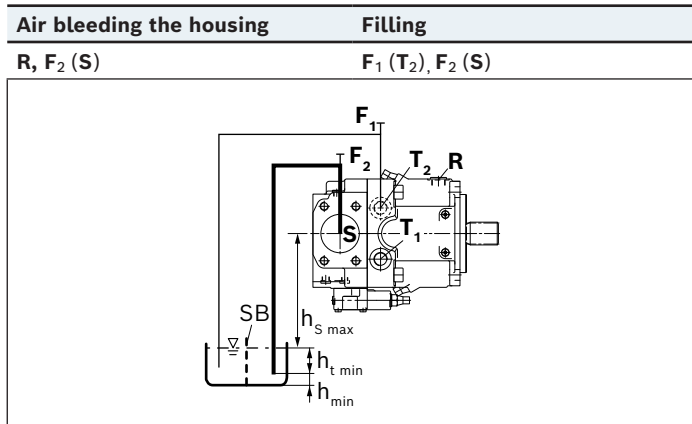

Installation position 7

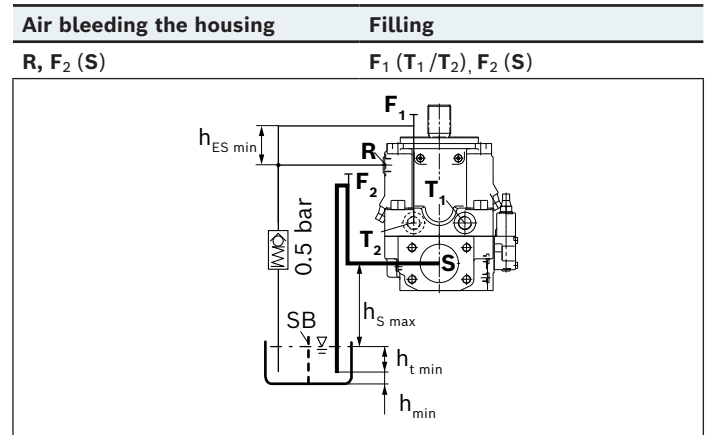

For key, see page 70.

Inside-reservoir installation

Inside-reservoir installation is when the axial piston unit is installed in the reservoir below the minimum fluid level. The axial piston unit is completely below the hydraulic fluid. If the minimum fluid level is equal to or below the upper edge of the pump, see chapter "Above-reservoir installation". Axial piston units with electric components (e.g. electric controls, sensors) may not be installed in a reservoir below the fluid level. If inside-reservoir installation is intended nevertheless, the IP protection class and the medium compatibility of the electric components used must be checked in the individual case. Please consult your proper contact person at Bosch Rexroth to commission an examination of the medium compatibility.

Installation position 8

Air bleeding the housing	Filling
--------------------------	---------

T₁ The housing of the axial piston unit is to be filled via **T₁** before attachment of the piping

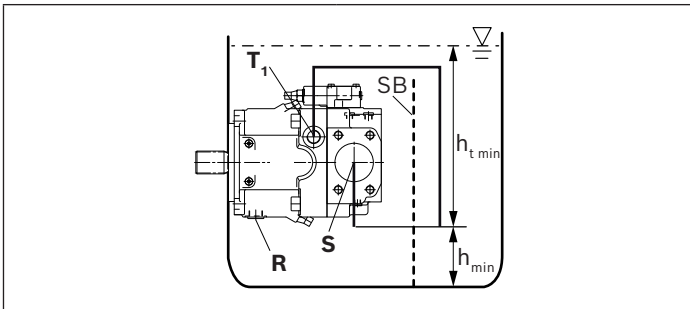

Installation position 9

Air bleeding the housing	Filling
--------------------------	---------

R The housing of the axial piston unit is to be filled via **T₁/T₂** before attachment of the piping

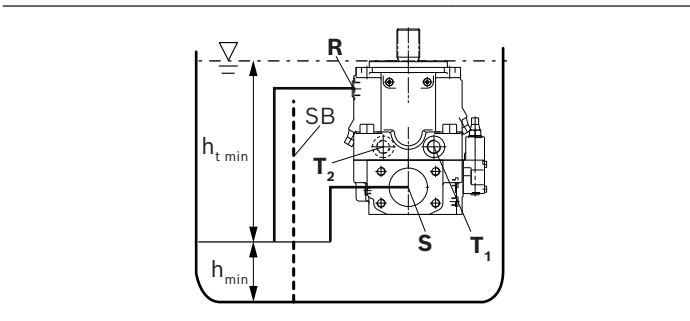

Installation position 10

Air bleeding the housing	Filling
--------------------------	---------

R The housing of the axial piston unit is to be filled using **T₂** before attachment of the piping

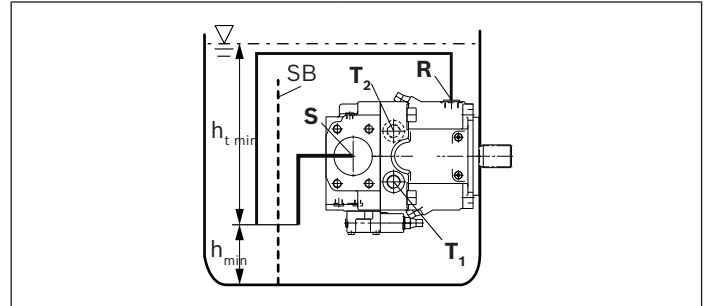

Notice

- ▶ Installation of the pump with EP control in the oil reservoir only when using mineral hydraulic oils and an oil temperature in the reservoir of max. 80 °C.
- ▶ In this case, the other drain port must be plugged. The housing of the axial piston unit must be filled before fitting the piping and filling the reservoir with hydraulic fluid.

For key, see page 70.

Project planning notes

- ▶ The pump is designed to be used in open circuits.
- ▶ Project planning, installation and commissioning of the axial piston units requires the involvement of skilled personnel.
- ▶ Before using the axial piston unit, please read the corresponding instruction manual completely and thoroughly. If necessary, this can be requested from Bosch Rexroth.
- ▶ Before finalizing your design, please request a binding installation drawing.
- ▶ The specified data and notes contained herein must be observed.
- ▶ Depending on the operating conditions of the axial piston unit (working pressure, fluid temperature), the characteristic curve may shift.
- ▶ Preservation: Our axial piston units are supplied as standard with preservation protection for a maximum of 12 months. If longer preservation protection is required (maximum 24 months), please specify this in plain text when placing your order. The preservation periods apply under optimal storage conditions, details of which can be found in the data sheet 90312 or the instruction manual.
- ▶ Not all versions of the product are approved for use in a safety function according to ISO 13849. Please consult the responsible contact person at Bosch Rexroth if you require reliability parameters (e.g. $MTTF_D$) for functional safety.
Depending on the type of control used, electromagnetic effects can be produced when using solenoids. Applying a direct voltage signal (DC) to solenoids does not create electromagnetic interference (EMI) nor is the solenoid affected by EMI. Electromagnetic interference (EMI) potential exists when operating and controlling a solenoid with a modulated direct voltage signal (e.g. PWM signal) Appropriate testing and measures should be taken by the machine manufacturer to ensure other components or operators (e.g. with pacemaker) are not affected by this potential.
- ▶ Pressure controllers are not safeguards against pressure overload. Be sure to add a pressure relief valve to the hydraulic system.
- ▶ Please note that a hydraulic system is an oscillating system. This can lead, for example, to the stimulation the natural frequency within the hydraulic system during operation at constant rotational speed over a long period of time. The excitation frequency of the pump is 9 times the rotational speed frequency. This can be prevented, for example, with suitably designed hydraulic lines.
- ▶ Please note the details regarding the tightening torques of port threads and other threaded joints in the instruction manual.
- ▶ The ports and fastening threads are designed for the p_{max} permissible pressures of the respective ports, see the connection tables. The machine or system manufacturer must ensure that the connecting elements and lines correspond to the specified application conditions (pressure, flow, hydraulic fluid, temperature) with the necessary safety factors.
- ▶ The working ports and function ports are only intended to accommodate hydraulic lines.

Safety instructions

- ▶ During and shortly after operation, there is a risk of burning on the axial piston unit and especially on the solenoids. Take the appropriate safety measures (e.g. by wearing protective clothing).
- ▶ Moving parts in control equipment (e.g. valve spools) can, under certain circumstances, get stuck in position as a result of contamination (e.g. contaminated hydraulic fluid, abrasion, or residual dirt from components). As a result, the hydraulic fluid flow and the build-up of torque in the axial piston unit can no longer respond correctly to the operator's specifications. Even the use of various filter elements (external or internal flow filtration) will not rule out a fault but merely reduce the risk.

The machine/system manufacturer must test whether remedial measures are needed on the machine for the application concerned in order to bring the driven consumer into a safe position (e.g. safe stop) and ensure any measures are properly implemented.

Bosch Rexroth AG

Glockeraustraße 2
89275 Elchingen
Germany
Phone +49 7308 82-0
info.ma@boschrexroth.de
www.boschrexroth.com

© Bosch Rexroth AG 1992. All rights reserved, also regarding any disposal, exploitation, reproduction, editing, distribution, as well as in the event of applications for industrial property rights. The data specified within only serves to describe the product. No statements concerning a certain condition or suitability for a certain application can be derived from our information. The information given does not release the user from the obligation of own judgment and verification. It must be remembered that our products are subject to a natural process of wear and aging.