

**HIGH PRESSURE
HOIST APPLICATIONS**

VARIABLE
DISPLACEMENTS
AXIAL PISTON
PUMPS

MVPR

INDEX

Section	Page
INTRODUCTION	3
GENERAL INFORMATION / INSTRUCTIONS	4
MOUNTING POSITIONS	5
FEATURES	7
DOUBLE SHAFT SEAL OPTION	9
DISPLACEMENT SETTING	10
CENTER OF GRAVITY	10
SINGLE PUMPS AND COMMON INLET MULTIPLE PUMPS	
DIMENSIONS	11
DRIVE SHAFTS	15
MOUNTING FLANGES	16
PORTS TYPE	18
REGULATORS	21
MULTIPLE PUMPS WITH THROUGH DRIVE	31
HOW TO ORDER	36

01/04.2022

INTRODUCTION

Variable displacement axial piston pumps swash plate design ideally suited for high pressure open circuit applications. “MVPR” series piston pump is an evolution of MVP series with higher pressure designed for hoist applications such as truck crane and telehandler for building & construction. A careful analysis of the application working cycle will ensure a long service life of the pump.

Please contact us for more information.

DISPLACEMENTS

From 55 cm³/rev (3.36 in³/rev)

To 84,7 cm³/rev (5.17 in³/rev)

PRESSURE

Max. constant operating pressure 350 bar (5075 psi)

Max. system pressure (relief valve setting) 380 bar (5510 psi)

Max. peak of pressure 400 bar (5800 psi)

SPEED

Max. 3000 min⁻¹

APPLICATION

High pressure hoist applications

SECTOR

Building & construction

TYPICAL APPLICATIONS

- Truck Cranes
- Telehandlers

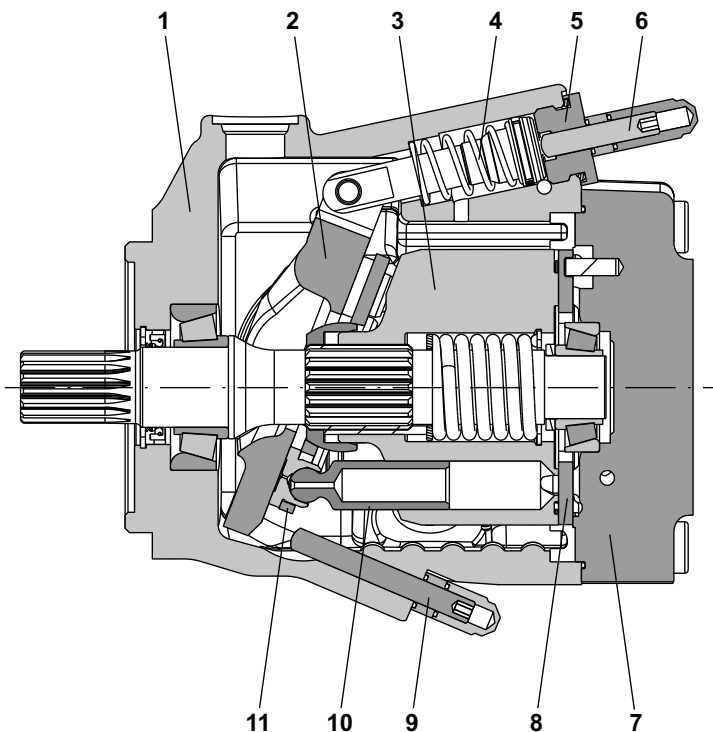

1	Pump body
2	Swash plate
3	Cylinders block
4	Counterbalancing spring
5	Plug
6	Max. displacement limiter
7	Cover
8	Valve plate
9	Min. displacement limiter
10	Piston
11	Piston guide plate

01/04.2022

- Compact design
- Low noise emission
- Max. and min. displacement limiter
- Drive shaft bearing suitable for radial and axial loads
- Hydraulic and Electro-hydraulic displacement controls

GENERAL INFORMATION / INSTRUCTIONS

DIRECTION OF ROTATION

Clockwise or anti-clockwise defined looking at the drive shaft.

HYDRAULIC FLUID

Mineral oil based hydraulic fluid conforming to DIN 51524 according to the technical data shown in the tables on page 7. The system should be designed to prevent aeration of the hydraulic fluid.

FLUID VISCOSITY

The fluid viscosity range for optimal use of MVPR pump is between 15 and 35 cSt (77 and 163 SSU).

Functional limit conditions are:

- max.: 1500 cSt (6818 SSU) at start up at minimum temperature of -25 °C (-13 °F) with straight and short inlet line.
 min.: 10 cSt (58 SSU) at maximum temperature of 110 °C (230 °F)

FILTRATION

To ensure the optimal performance and the maximum life to the pump, the hydraulic fluid must have and maintain a fluid contamination within the values shown in the table below.

Working pressure bar (psi)	$\Delta p < 140$ (2030)	$140 < \Delta p < 210$ (2030) (3045)	$\Delta p > 210$ (3045)
Contamination class NAS 1638	9	8	7
Contamination class ISO 4406:1999	20/18/15	19/17/14	18/16/13
Achieved with filter $\beta_{x_{(0)}} \geq 75$ according to ISO 16889	10 μm	10 μm	10 μm

Casappa recommends to use its own production filters:



STORAGE

The storage must be in a dry environment. Max storage time in ideal conditions is 24 months. The ideal storage temperature is between 5 °C (41 °F) and 20 °C (68 °F). No problem in case of temperature between -40 °C (-40 °F) and 50 °C (122 °F). Below -40 °C (-40 °F) please consult our pre-sales department.

INSTALLATION

Check that the maximum coupling eccentricity stays within 0,25 mm (0.0098 in) to reduce shaft loads due to misalignment. It is advised to use a flexible coupling suitable to absorb eventual rotational shocks. For applications with axial and radial loads exceeding published standards, consult our sales department. The direction of rotation of the pump must agree with the prime mover rotation. Before installation, the case of the pump must be filled with fluid.

LINES

The lines must have a major diameter which is at least as large as the diameter of pump ports, and must be perfectly sealed. To reduce loss of power, the lines should be as short as possible, reducing the sources of hydraulic resistance (elbow, throttling, gate valves, etc.) to a minimum. A length of flexible tubing is recommended to reduce the transmission of vibrations. Before connecting the lines, remove any plug and make sure that the lines are perfectly clean. Check that the drain line is dimensioned in a way to guarantee a case pressure lower than 1,5 bar (22 psi) absolute. The drain line must be connected directly (no filter, no valves, no oil cooler) to the tank and must terminate below the oil level. Check that the dimensions of the suction line guarantee a pressure equal or superior to 0,8 bar (12 psi). Inlet pressure less than 0,8 bar (12 psi) could cause an increase of noise emission, the decrease of the pump performances and a reduction of its life expectancy.

STARTING UP

Check that all connections are secure and that the entire system is completely clean. Add oil to the tank always using a filter. Bleed the air from the circuit to help the filling. Turn on the system for a few moments at minimum speed, then bleed the circuit again and check the level of oil in the tank. Gradually increase the pressure and speed of rotation up to the pre-set operating levels, which must stay within the stated limits as specified in the catalogue.

FOR VERY LOW TEMPERATURE

STARTING UP

We strongly recommend to warm up the oil before running the machine. If this is not possible, the warm up of the oil and of the pump should be carried out following these instructions:

- Start the pump in stand-by condition at minimum speed.
 Keep this working condition until the pump case reaches -20 °C (-4 °F)
- Increase slowly the displacement. Max pressure permitted: 50 bar (725 psi). The maximum permitted speed is strictly connected to the layout of the inlet circuit; check that there is no cavitation before increasing the speed.
- Keep this working condition until the oil temperature in the whole system is -10 °C (14 °F).
- Maximum pressure can be achieved from now on.
- Always check the outlet flow to prevent cavitation damage.

All the temperature are referred to oil with viscosity ISO VG 32 according to DIN 51 519.

SUGGESTIONS

To prevent cavitation at low temperature we suggest:

- To warm up the tank
- To pressurize the tank
- To oversize the inlet hose

05/10.2014

MOUNTING POSITIONS

Standard pump is supplied with D1 drain hole open and D2, D3, D4 plugged (♦ if available).

Before installation fill the pump with hydraulic oil for at least 3/4 of the volume keeping it in horizontal position.

The pump can be mounted in a horizontal or vertical position. The highest of the case drain ports must be used to keep the required filling oil.

If D1 is not the highest drain port it must be closed by moving the plug from the hole chosen for the drain line.

The pump can be located above the oil level if the absolute pressure at the inlet port stays within the stated limits.

With exception of pump mounted below the oil level, we recommend to interpose a baffle plate between inlet and drain line.

To reduce further noise emission, we recommend to mount the pump below the oil level and avoid suction lines with sharp restrictions.

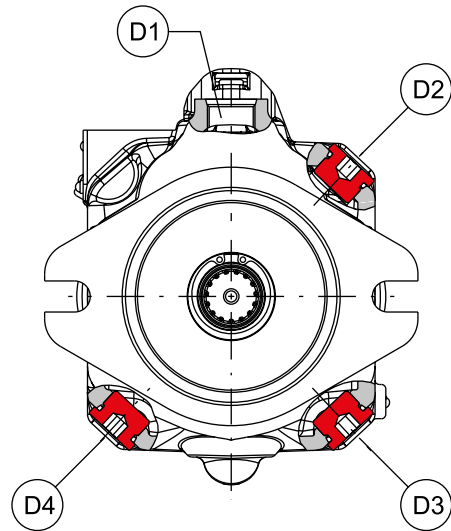

HORIZONTAL MOUNTING		VERTICAL MOUNTING	
	<p>Arrangement inside the tank.</p> <p>Minimum oil level equal or above the pump mounting face.</p> <p>$A \geq 200 \text{ mm (7.874 in)}$</p>		<p>Arrangement inside the tank.</p> <p>Minimum oil level equal or above the pump mounting face.</p> <p>$A \geq 200 \text{ mm (7.874 in)}$</p>
	<p>Arrangement inside the tank.</p> <p>Minimum oil level below the pump mounting face.</p> <p>Min. inlet pressure= 0,8 bar abs (24 in Hg)</p> <p>$B \leq 800 \text{ mm (31.4961 in)}$</p> <p>$C = 200 \text{ mm (7.874 in)}$</p>		<p>Arrangement inside the tank.</p> <p>Minimum oil level below the pump mounting face.</p> <p>Min. inlet pressure= 0,8 bar abs (24 in Hg)</p> <p>$B \leq 800 \text{ mm (31.4961 in)}$</p> <p>$C = 200 \text{ mm (7.874 in)}$</p>
	<p>Arrangement outside the tank above oil level.</p> <p>Min. inlet pressure= 0,8 bar abs (24 in Hg)</p> <p>$B \leq 800 \text{ mm (31.4961 in)}$</p> <p>$C = 200 \text{ mm (7.874 in)}$</p>		<p>Arrangement outside the tank above oil level.</p> <p>Min. inlet pressure= 0,8 bar abs (24 in Hg)</p> <p>$B \leq 800 \text{ mm (31.4961 in)}$</p> <p>$C = 200 \text{ mm (7.874 in)}$</p>
	<p>Arrangement outside the tank below oil level.</p> <p>$C = 200 \text{ mm (7.874 in)}$</p>		

06/06.2020

IN= inlet line - D1= drain line - A= min. distance between the line - B+C= permissible suction height - C= line immersion depth

PRESSURE DEFINITION

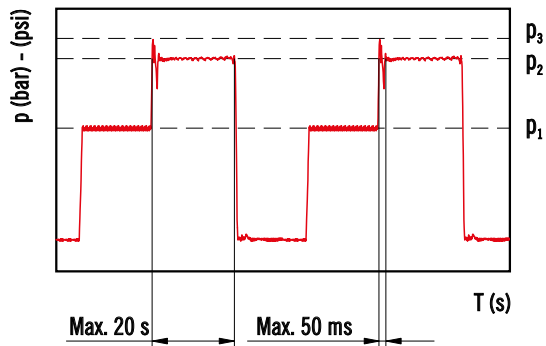

- p_1 Constant operating pressure
- p_2 System pressure (relief valve setting)
- p_3 Peak of pressure

The peak of pressure is the max pressure allowed and it corresponds to the overshoot of the relief valve.

Please note that both relief valve setting and overshoot must be lower than their limits.

If the relief setting is compliant but the overshoot is higher than the limit, the relief setting must be decreased until the overshoot is compliant to Casappa limit.

Please contact us for high frequency applications.

FEATURES

Technical data with mineral oil

HL or HLP mineral oil based hydraulic fluid to DIN 51524

Pump type MVPR			60-60	60-72	60-84
Max. displacement (theor.) V_{max}	cm ³ /rev (in ³ /rev)		60 (3.66)	72 (4.39)	84,7 (5.17)
Inlet pressure	bar abs. (in Hg)	min.		0.8 (24)	
	bar abs. (psi)	max.		25 (363)	
Max. outlet pressure p_{max}	bar (psi)	p_1	350 (5075) (◆)	350 (5075) (◆)	315 (4568) (◆)
		p_2	380 (5510) (◆)	380 (5510) (◆)	350 (5075) (◆)
		p_3	400 (5800) (◆)	400 (5800) (◆)	380 (5510) (◆)
(◆) Max. pressures are achievable only limiting the maximum torque up to:	Nm (lbf in)		420 (6090)	420 (6090)	420 (6090)
Max. drain line pressure	bar abs. (psi)			1,5 (22)	
Max. speed n_{max}	min ⁻¹	@ V_{max} (1)	3000	2700	2300
		@ n_{max}	180 (47.6)	194 (51.3)	194 (51.3)
Max. delivery (theor.)	l/min (US gpm)	@ 2000 min ⁻¹	120 (31.7)	144 (38.0)	169 (44.7)
		@ 1500 min ⁻¹	90 (23.8)	108 (28.5)	127 (33.6)
		@ n_{max}	84 (112.6)	90,7 (121.5)	102 (136.7)
Max. power (theor.) ($\Delta p = p_{max}$ cont.)	kW (HP)	@ 2000 min ⁻¹	56 (75.0)	67,2 (90.0)	70,6 (94.6)
		@ 1500 min ⁻¹	42 (56.3)	50,4 (67.5)	52,9 (70.9)
		@ p_{max} cont.	267,4 (2367)	320,9 (2840)	337 (2983)
Max. torque (theor.)	Nm (lbf in)	@ 100 bar (1450 psi)	95,5 (845)	114,6 (1014)	134,8 (1193)
Moment of inertia rotary group	kgm ² (ft ² lbs)		0,008 (0.19)	0,008 (0.19)	0,008 (0.19)
Fill volume	l (US gallons)		1,3 (0.34)	1,3 (0.34)	1,3 (0.34)
Mass (approx.)	kg (lbs)		22 (48.5)	22 (48.5)	22 (48.5)
Seals			N= Buna		V= Viton
Operating temperature	°C (°F)	min.	-25 (-13)		-15 (5)
		max. cont.	80 (176)		110 (230)
		max. peak	100 (212)		125 (257)

01/04.2022

(1) = with an inlet pressure of 1 bar abs (14.5 psi) and viscosity between 15 and 35 cSt (77 and 163 SSU). Reducing the displacement or increasing the inlet pressure the max. speed changes. See table at page 10.
 Max. speed limit are: MVPR 60: 3000 m⁻¹
 Please contact us for different working conditions.

FEATURES

Design calculations for pump

Q	l/min (US gpm)	Flow
M	Nm (lbf in)	Torque
P	kW (HP)	Power
V	cm ³ /rev (in ³ /rev)	Displacement
n	min ⁻¹	Speed
Δp	bar (psi)	Pressure
$\eta_v = \eta_v(V, \Delta p, n)$		Volumetric efficiency
$\eta_{hm} = \eta_{hm}(V, \Delta p, n)$		Hydro-mechanical efficiency
$\eta_t = \eta_v \cdot \eta_{hm}$		Overall efficiency

$$Q = Q_{theor.} \cdot \eta_v$$

$$Q_{theor.} = \frac{V \text{ (cm}^3\text{/rev)} \cdot n \text{ (min}^{-1}\text{)}}{1000} \quad [\text{l/min}]$$

$$M = \frac{M_{theor.}}{\eta_{hm}}$$

$$M_{theor.} = \frac{\Delta p \text{ (bar)} \cdot V \text{ (cm}^3\text{/rev)}}{62,83} \quad [\text{Nm}]$$

$$P_{in} = \frac{P_{out}}{\eta_t}$$

$$P_{out} = \frac{\Delta p \text{ (bar)} \cdot Q \text{ (l/min)}}{600} \quad [\text{kW}]$$

Max. permissible load on drive shaft

Pump type		MVPR 60•60	MVPR 60•72	MVPR 60•84	
	F_{ax} Axial force	N (lbf)	2000 (450)	2000 (450)	2000 (450)
	F_{rad} Radial force	@ L/2 N (lbf)	3000 (675)	3000 (675)	3000 (675)

% Variation of the max. speed in relation of the inlet pressure and/or displacement reduction

Inlet pressure	Displacement %					% Variation of the max. speed
	65	70	80	90	100	
psi (bar abs)						
12 (0,8)	120	115	105	97	90	01/04.2022
13 (0,9)	120	120	110	103	95	
14.5 (1,0)	120	120	115	107	100	
17 (1,2)	120	120	120	113	106	
20 (1,4)	120	120	120	120	112	
23 (1,6)	120	120	120	120	117	
29 (2,0)	120	120	120	120	120	

Max. speed must not exceed the limits specified at page 7.

Example 1

Displacement: 100 %
 Speed: 100 %
 Inlet pressure: 1,0 bar abs. (14.5 psi)

Example 2

Displacement: 80 %
 Inlet pressure: 1,0 bar abs. (14.5 psi)
 Speed: 115 %

FEATURES

Definition of rotation direction looking at the drive shaft

Anti-clockwise rotation

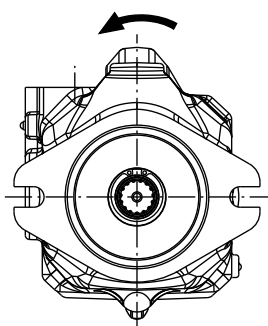

Side ports

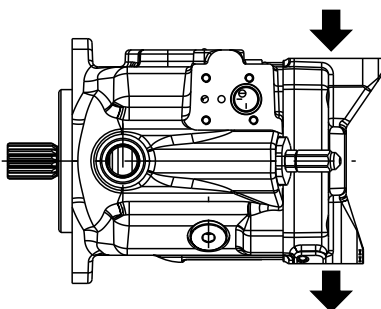

Rear ports

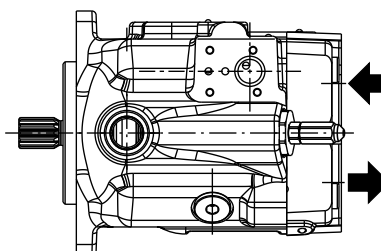

Clockwise rotation

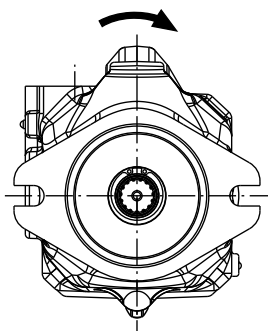

Side ports

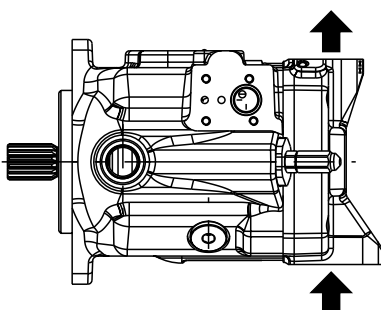

Rear ports

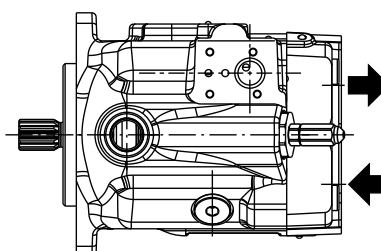

DOUBLE SHAFT SEAL OPTION

The double shaft seal is available for the following configuration:

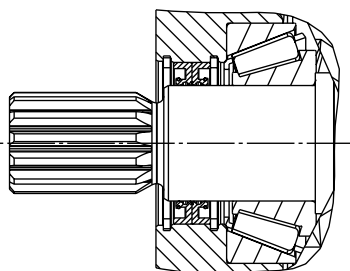

Pump type	MOUNTING FLANGES		
	S5	S7	S8
MVPR 60		X	X

X Available combination

01/04.2022

DISPLACEMENT SETTING

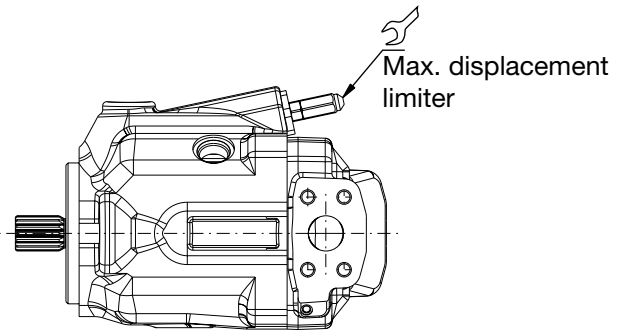
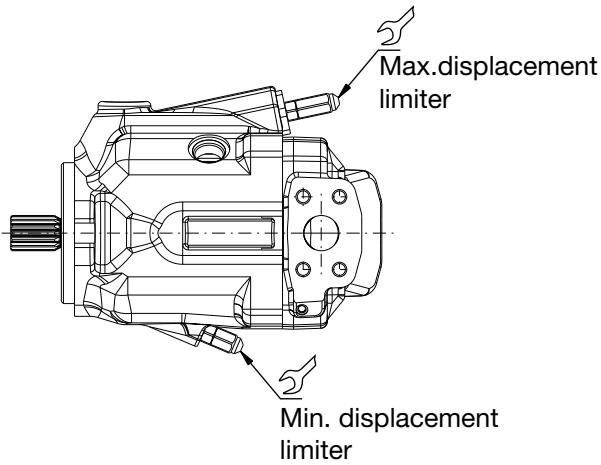

*

* Special body without Min. displacement limiter is available only on request, please contact us for more information

E: Max. displacement limiter (Min displacement limiter is plugged)

G: Min. and Max. displacement limiter

 Tightening torque 15^{±1} Nm (124 ÷ 142 lbf in)

MVPR 60

Max. displacement setting range	cm ³ /rev (in ³ /rev)	from	55 (3.36)
		to	84,7 (5.17)
Min. displacement setting range	cm ³ /rev (in ³ /rev)	from	0
		to	38,1 (2.32)
One turn of screw changes pump displacement by approximately	cm ³ /rev (in ³ /rev)	E	5,0 (0.31)
		F	4,2 (0.26)

Please contact us for different setting range.

CENTER OF GRAVITY

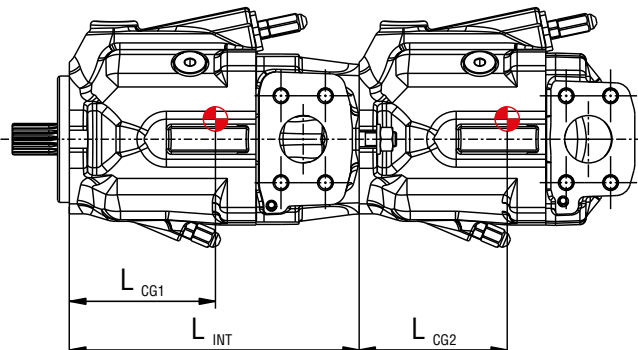

 Center of gravity

$$M_{MF} = \frac{L_{CG1} \cdot m_1 + (L_{INT} + L_{CG2}) \cdot m_2}{102} \quad [\text{Nm}]$$

M_{MF} : Load moment on mounting flange

L_{CG} : Distance from center of gravity to mounting flange [mm]

m : Weight (kg)

MVPR 60

L_{CG1}	mm (in)	120 (4.72)
L_{CG2}	mm (in)	107 (4.21)
L_{INT}	mm (in)	253 (9.96)

For single pumps refer to L_{CG2} values
Average data, please contact us for specific values.

01/04.2022

MVPR60

SIDE PORTS - DIMENSIONS

L

Drive shafts: see page 15
 Mounting flanges: see page 16 ÷ 17
 Ports: see page 18 ÷ 20

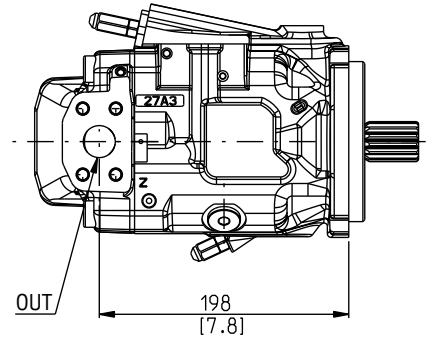
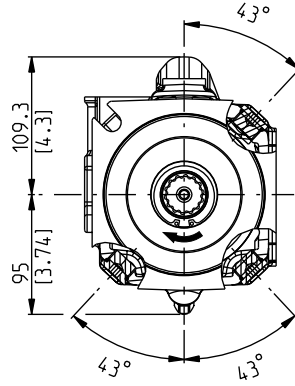
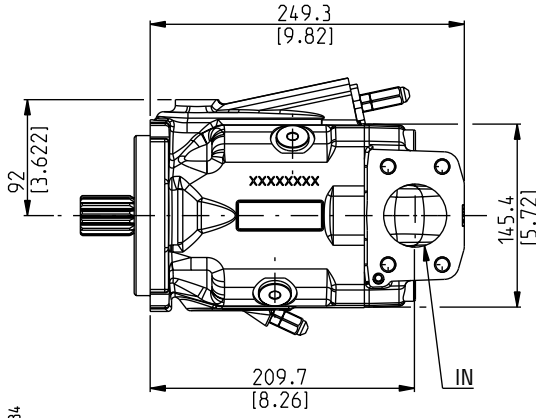

DCAT_048_034

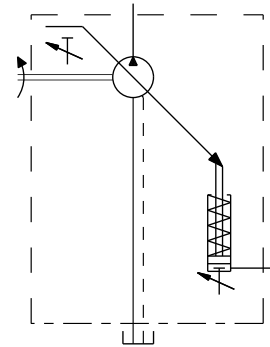
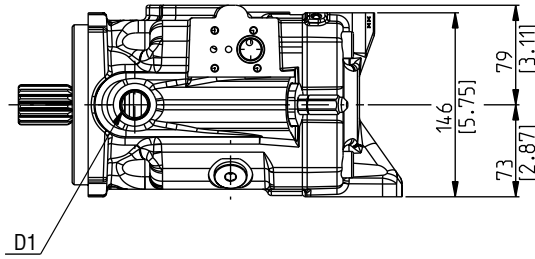

01/04.2022

Drive shafts: see page 15
 Mounting flanges: see page 16 ÷ 17
 Ports: see page 18 ÷ 20

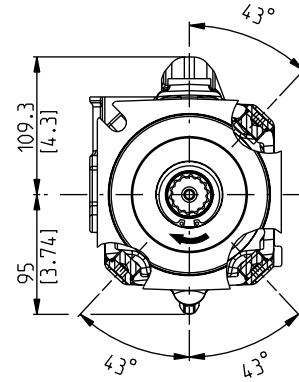
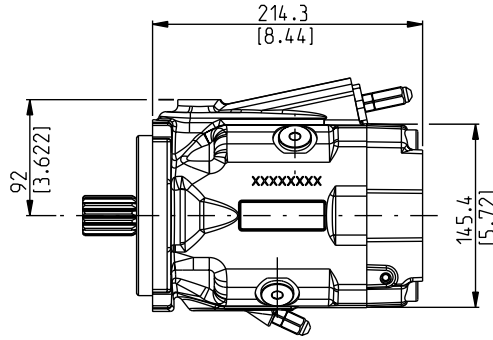
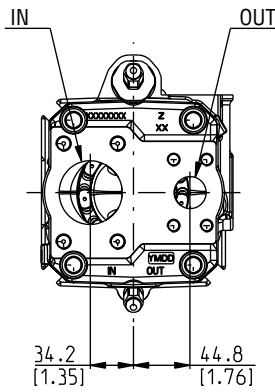

DCAT_048_005

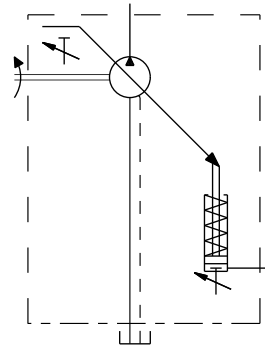
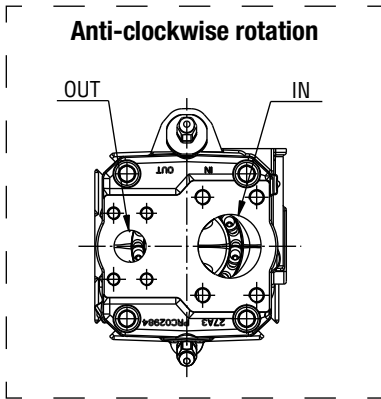
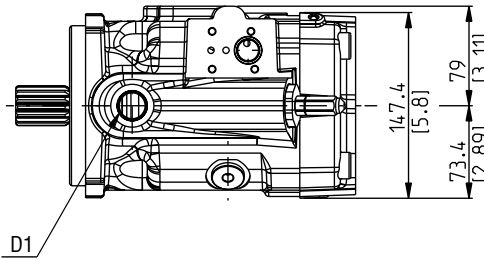

01/04.2022

MVPR60/KP20

MULTIPLE PUMPS - DIMENSIONS

L

Common inlet intermediate flange:
MVP code **P7**
KP20 code **N5**

Drive shafts: see page 15
Mounting flanges: see page 16 ÷ 17
Ports: see page 18 ÷ 20

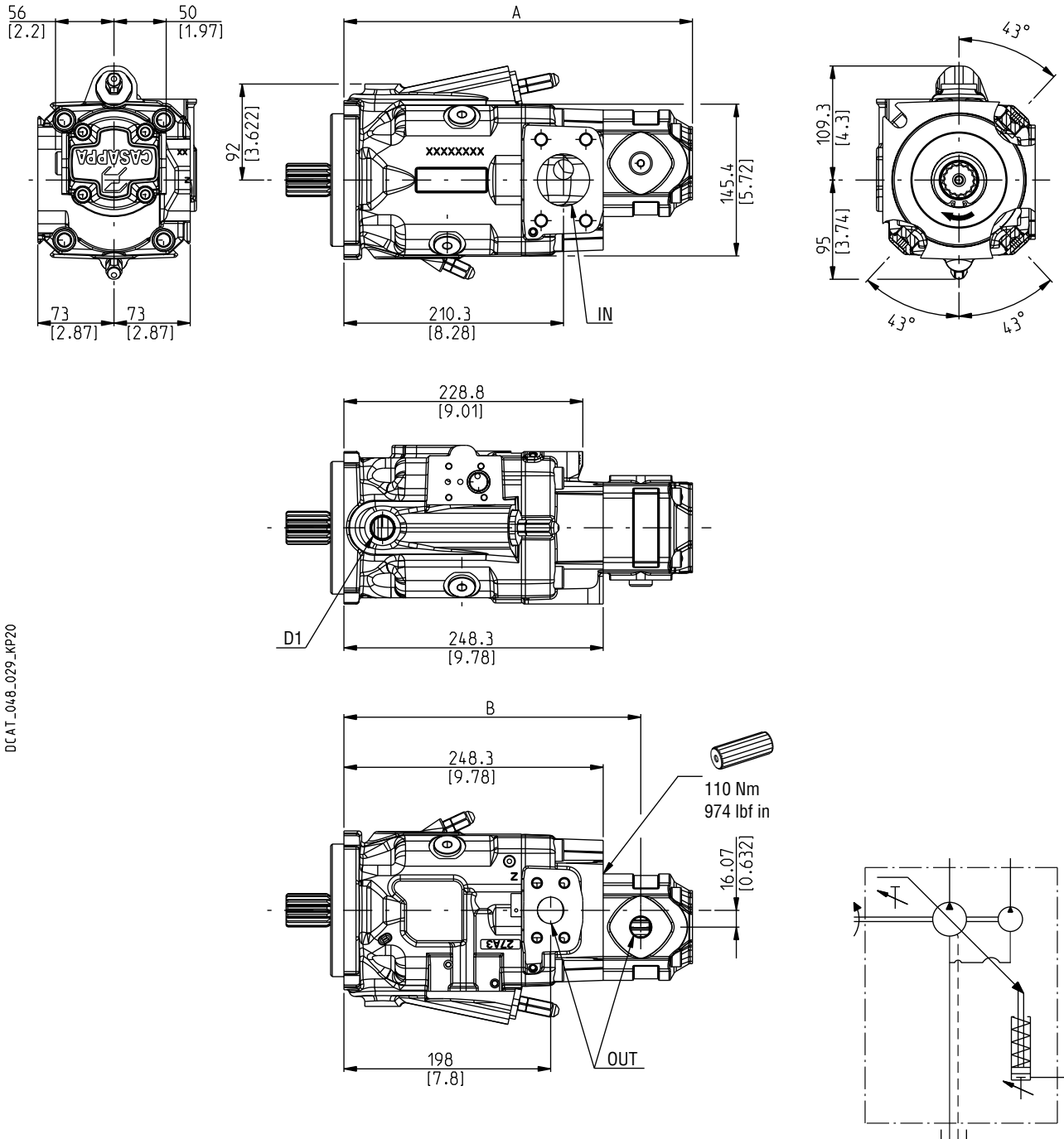

DCAT_048_029_KP20

01/04.2022

Gear pump KAPPA 20 (for more information please see the respective technical catalogue)

Pump type	4	6,3	8	11,2	14	16	20	Dimensions
MVPR60	301,3 (11.86)	303,8 (11.96)	306,3 (12.06)	309,8 (12.20)	313,8 (12.35)	319,3 (12.57)	325,8 (12.83)	mm (in) A
	272,3 (10.72)	274,8 (10.82)	277,3 (10.92)	280,8 (11.06)	279,3 (11.00)	284,8 (11.21)	291,3 (11.47)	mm (in) B

MVPR60/PHP20

MULTIPLE PUMPS - DIMENSIONS

L

Common inlet intermediate flange:
MVP code **I7**
PHP20 code **S7**

Drive shafts: see page 15
Mounting flanges: see page 16 ÷ 17
Ports: see page 18 ÷ 20

Also available in
combination with PLP20

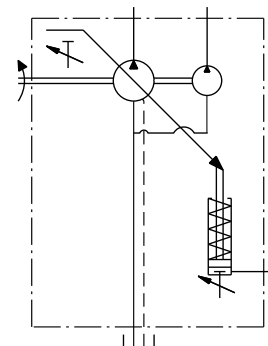
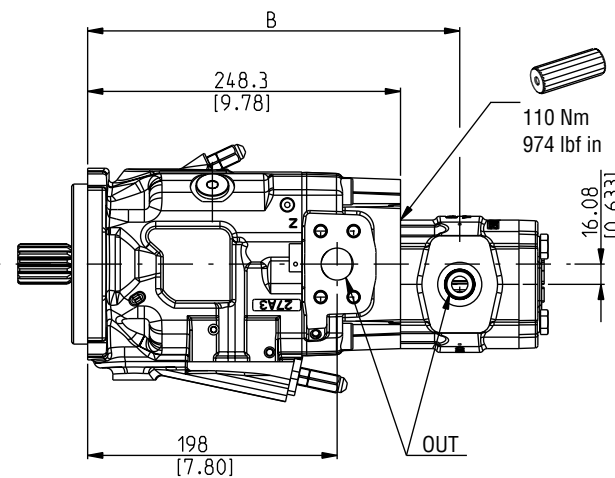
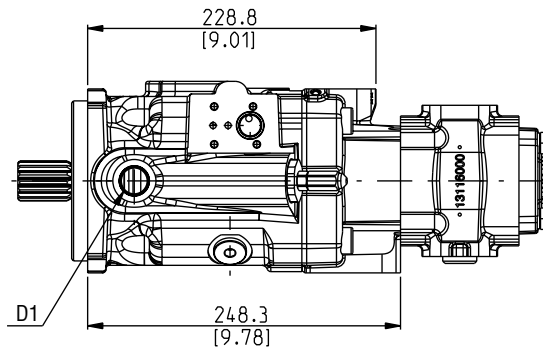
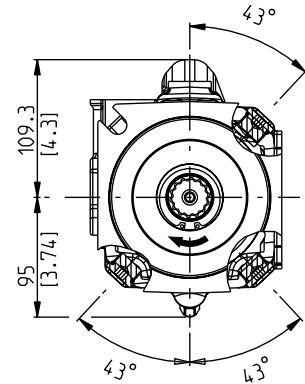
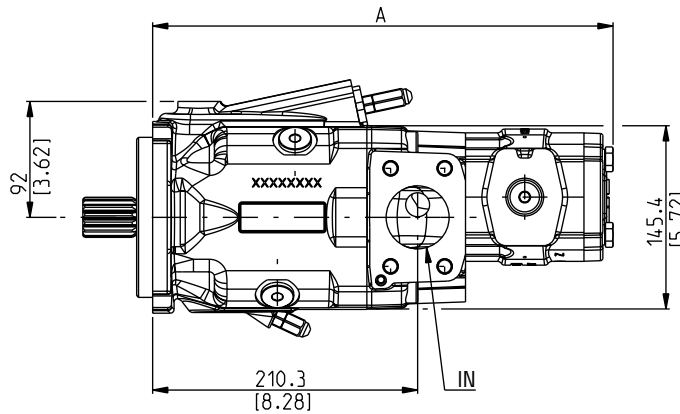
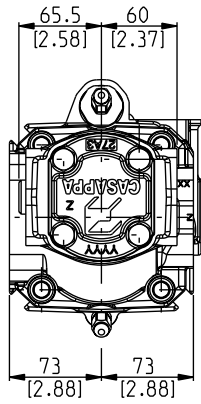

DCAT_048_035_PHP

01/04.2022

Gear pump POLARIS PH20 (for more information please see the respective technical catalogue)

Pump type	8	10,5	11,2	14	16	18	19	20	23	24,5	25	27,8	31,5	Dimensions
MVPR60	328,4 (12.93)	332,4 (13.09)	332,9 (13.11)	337,9 (13.30)	341,4 (13.44)	343,6 (13,53)	344,8 (13.57)	347,9 (13.70)	351,4 (13.83)	353,7 (13.93)	355,4 (13.99)	358,2 (14.10)	365,4 (14.39)	mm (in) A
	281,8 (11.09)	284,8 (11.21)	285,3 (11.23)	290,3 (11.43)	293,3 (11.55)	284,2 (11.19)	284,8 (11.21)	286,3 (11.27)	288 (11.34)	289,1 (11.38)	290,3 (11.43)	291,7 (11.48)	295,3 (11.63)	mm (in) B

MVPR60

DRIVE SHAFTS

SAE "B" SPLINE

04

Mounting face refers to flange code **S5**

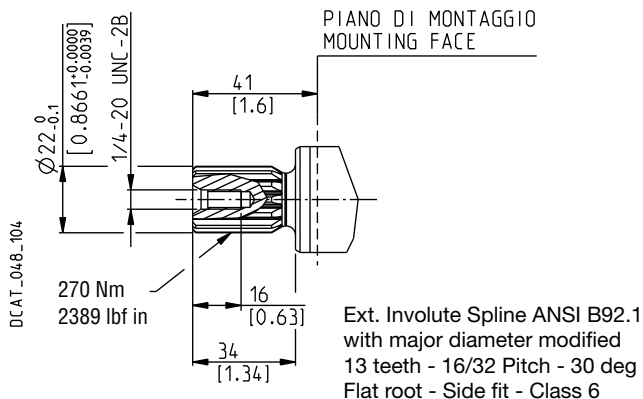

SAE "BB" SPLINE

05

Mounting face refers to flange code **S5**

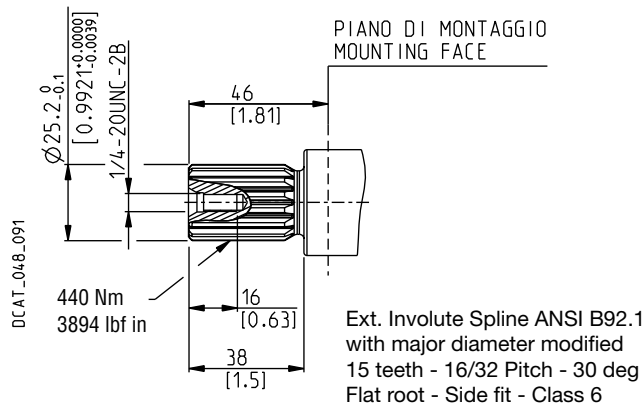

SAE "BB" SPLINE

5R

Mounting face refers to flange code **S5**

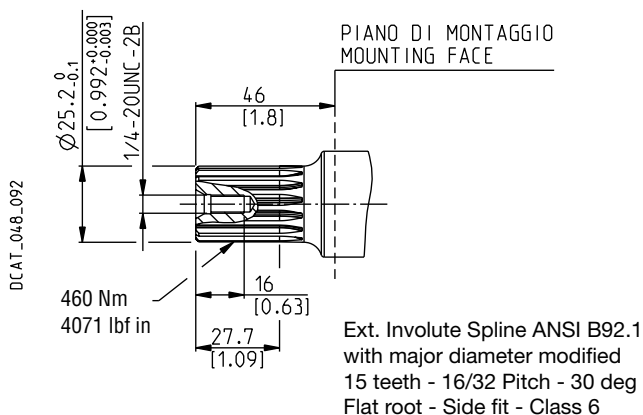

SAE "C" SPLINE

06

Mounting face refers to flange code **S7** and **S8**

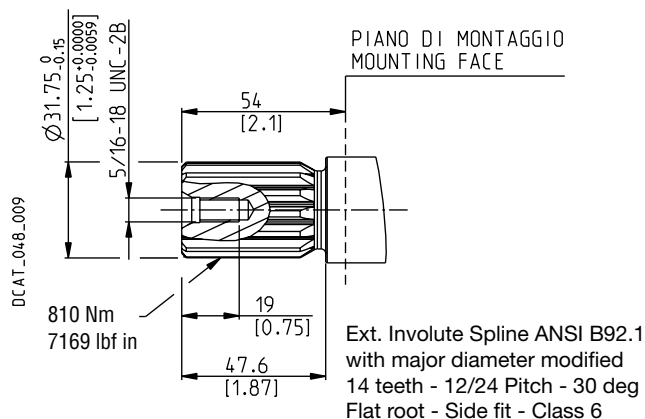

SAE "C" SPLINE

6R

Mounting face refers to flange code **S7** and **S8**

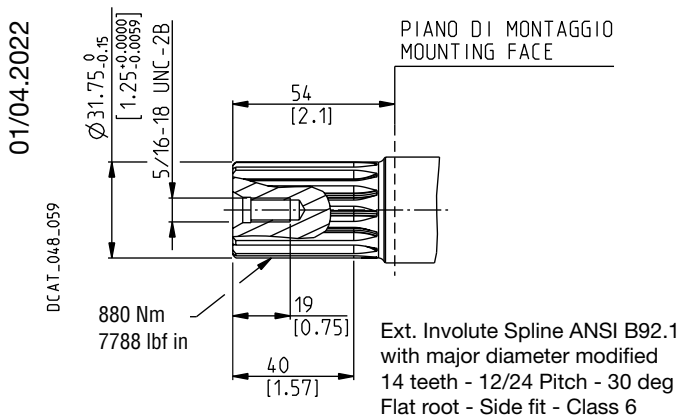

SAE "C" STRAIGHT

34

Mounting face refers to flange code **S8**

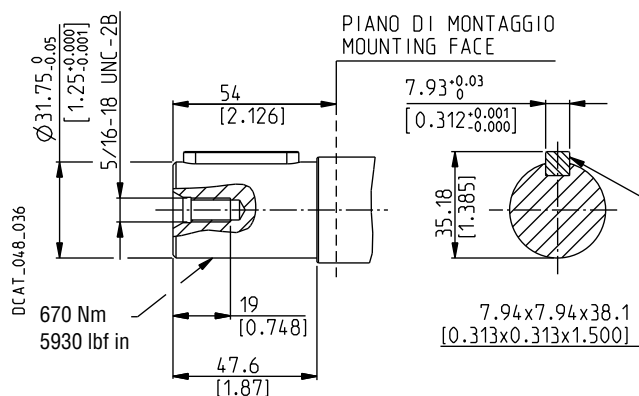

01/04.2022

Please contact us for different drive shafts.

MOUNTING FLANGES AND TABLE OF COMPATIBILITY

SAE "B" 2 HOLES

S5

Conforms to SAE J744

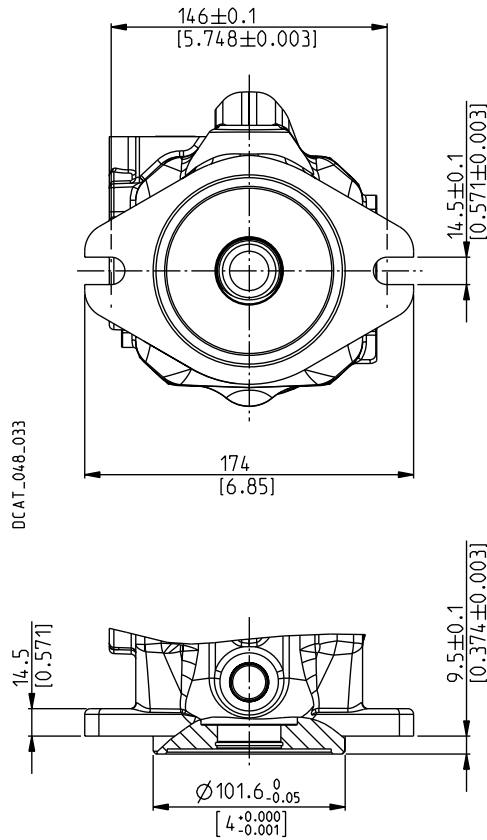

SAE "C" 2 HOLES

S7

Conforms to SAE J744

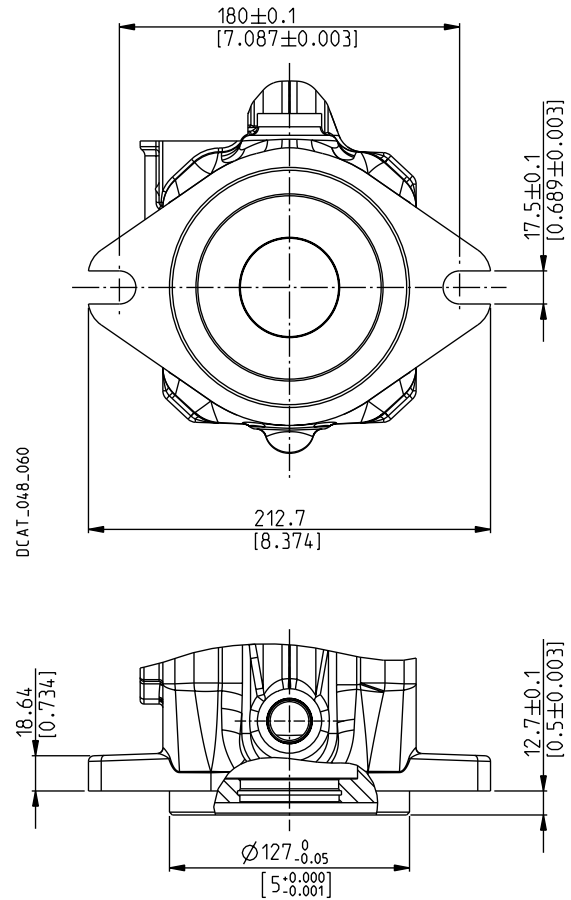

DRIVE SHAFTS

See page 17

Pump type	04	05	5R	06	6R	34
MVPR60	X	X	X	X	X	X

X Available combination

DRIVE SHAFTS

See page 17

Pump type	04	05	5R	06	6R	34
MVPR60	X	X	X	X	X	X

X Available combination

01/04.2022

MOUNTING FLANGES AND TABLE OF COMPATIBILITY

SAE "C" 4 HOLES

S8

Conforms to SAE J744

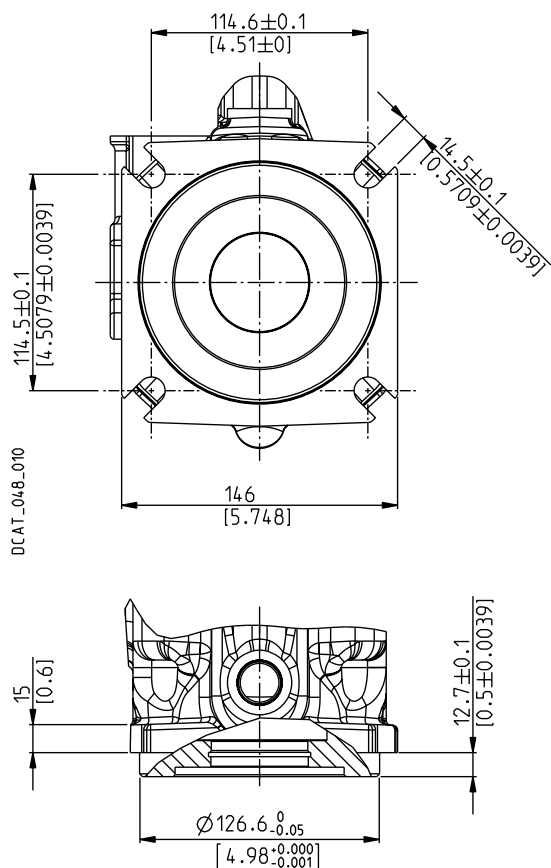

DRIVE SHAFTS

See page 17

Pump type	04	05	5R	06	6R	34
MVPR60	X	X	X	X	X	X

X Available combination

01/04.2022

PORTS TYPE

Ports type	INLET / OUTLET PORTS						DRAIN PORTS		LOAD SENSING PORTS (X)		KP20 / PHP20 GEAR PUMPS	
	Split SSM		Split SSS		SAE ODT		Gas BSPP	SAE ODT (●)	Gas BSPP (●)	SAE ODT	Gas BSPP	SAE ODT
	IN	OUT	IN	OUT	IN	OUT	D1 - D2 - D3 - D4		X	X	OUT	OUT
MVPR60	MF	MC	SF	SC	MF	OF	GD	OC	GA	03	GD	OC

(X) Load sensing port. Please contact us for more information.

(●) Standard.

(■) Only for rear ports.

DRAIN PORTS POSITION

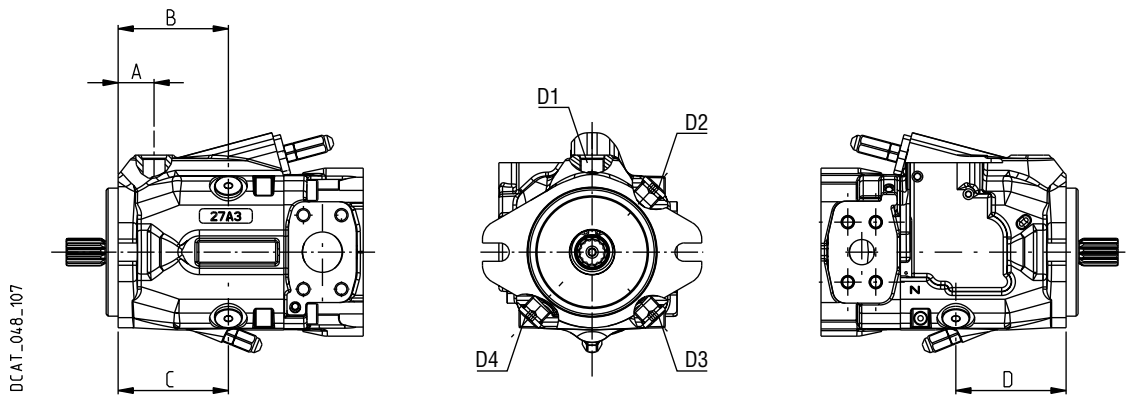

Pump type	A	B	C	D
	mm (in)	mm (in)	mm (in)	mm (in)
MVPR60	37 (1.46)	113 (4.45)	99 (3.90)	99 (3.90)

PORTS TYPE



 Tightening torque for low pressure side port

 Tightening torque for high pressure side port

SAE FLANGED PORTS J518 - Standard pressure series 3000 psi - Code 61

SSM

Metric thread ISO 60° conforms to ISO/R 262

CODE	Nominal size	A	B	C	D		
		mm (in)	mm (in)	mm (in)	Thread Depth mm (in)	Nm (lbf in)	Nm (lbf in)
MC	1"	25,4 (1.00)	52,4 (2.06)	26,2 (1.03)	M 10 17 (0.67)	—	30 ^{+2,5} (266 ÷ 288)
MF	2"	51 (2.01)	77,8 (3.06)	42,9 (1.69)	M 12 20 (0.79)	30 ^{+2,5} (266 ÷ 288)	—

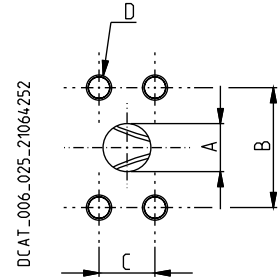



DCAT_006_025_21064252

SAE FLANGED PORTS J518 - Standard pressure series 3000 psi - Code 61

SSS

American straight thread UNC-UNF 60° conforms to ANSI B 1.1

CODE	Nominal size	A	B	C	D		
		mm (in)	mm (in)	mm (in)	Thread Depth mm (in)	Nm (lbf in)	Nm (lbf in)
SC	1"	25,4 (1.00)	52,4 (2.06)	26,2 (1.03)	3/8 - 16 UNC-2B 17 (0.67)	—	35 ^{+2,5} (310 ÷ 332)
SF	2"	51 (2.01)	77,8 (3.06)	42,9 (1.69)	1/2 - 13 UNC-2B 20 (0.79)	30 ^{+2,5} (266 ÷ 288)	—

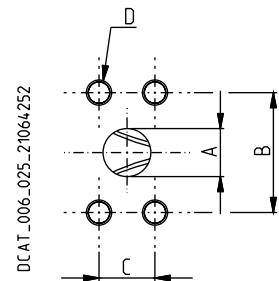

DCAT_006_025_21064252

01/04.2022

PORTS TYPE

 Tightening torque for low pressure side port



 Tightening torque for high pressure side port

SAE STRAIGHT THREAD PORTS J514

ODT

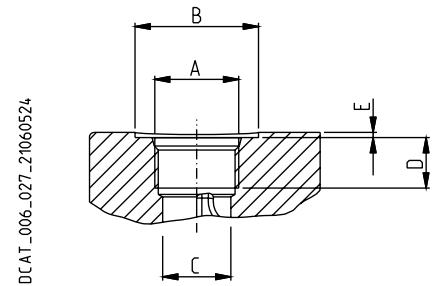
American straight thread UNC-UNF 60° conforms to ANSI B 1.1



CODE	Nominal size	A	Ø B	Ø C	D	E		
							Nm (lbf in)	Nm (lbf in)
03 (X)	1/4"	7/16" - 20 UNF - 2B	—	9,5 (0.37)	—	—	—	12 ⁺¹ (106 ÷ 115)
0B (●)	1/2"	3/4" - 16 UNF - 2B	33 (1.30)	17 (0.67)	—	1 (0.04)	20 ⁺¹ (177 ÷ 186)	—
0C (●)	5/8"	7/8" - 14 UNF - 2B	35 (1.38)	20,5 (0.81)	—	2 (0.08)	30 +2,5 (266 ÷ 288)	—
0C (◆)			34 (1.34)	20,5 (0.81)	17 (0.67)	0,5 (0.02)	—	70 ⁺⁵ (620 ÷ 664)
0F	1"	1 5/16" - 12 UNF - 2B	—	30,5 (1.20)	20 (0.79)	—	—	170 ⁺¹⁰ (1505 ÷ 1593)



(X) = Load sensing port - (●) = Drain port - (◆) = KP20 / PHP20 outlet port

GAS STRAIGHT THREAD PORTS

BSPP

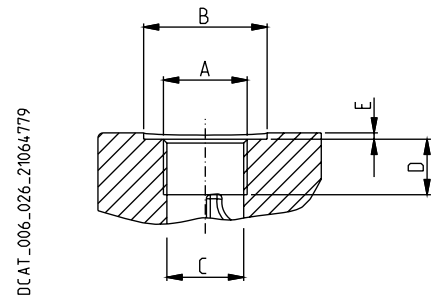
British standard pipe parallel (55°) conforms to UNI - ISO 228



CODE	Nominal size	A	Ø B	Ø C	D	E		
							Nm (lbf in)	Nm (lbf in)
GA (X)	1/8"	G 1/8	—	8,75 (0.34)	12 (0.47)	—	—	5 ^{+0,25} (44 ÷ 46)
GD (●)	1/2"	G 1/2	30 (1.18)	19 (0.75)	17 (0.67)	2 (0.08)	20 ⁺¹ (177 ÷ 186)	—
GD (◆)			—	19 (0.75)	17 (0.67)	—	—	50 ^{+2,5} (443 ÷ 465)

(X) = Load sensing port - (●) = Drain port - (◆) = KP20 / PHP20 outlet port

01/04.2022

PRESSURE COMPENSATOR

RP1

Regulates the pump displacement automatically to maintain the pressure below the fixed pre-adjusted limit.
Designed to work at high frequency ≥ 2 cycle/min and/or at pressure > 280 bar (4060 psi).

OPERATING CURVES

Curves have been obtained at the speed of 1500 min^{-1} and oil temperature $50 \text{ }^\circ\text{C}$ ($122 \text{ }^\circ\text{F}$).

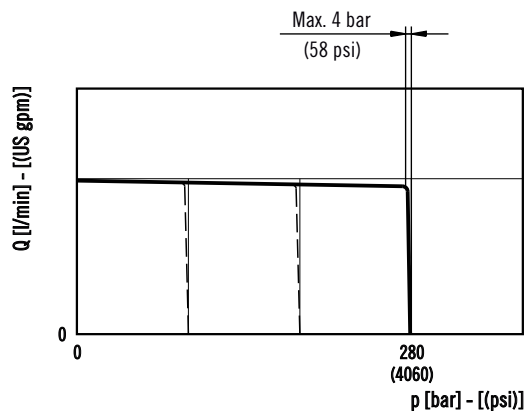

RP1

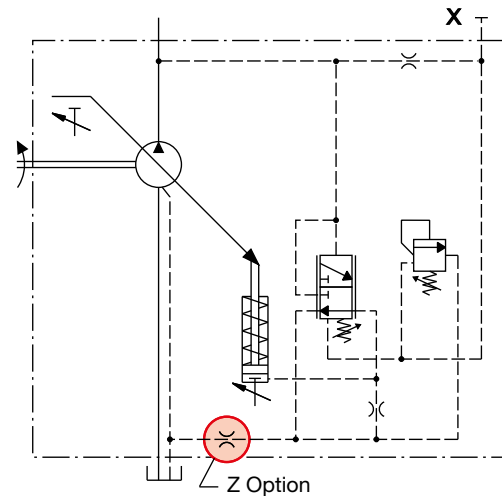

Z OPTION

Damping restrictor for critical applications. In case of system instability or pressure oscillations, the additional damping restrictor slows down the pump control system, damping the regulation transients. The pump recovery time increases. The use of the damping restrictor must be evaluated and approved by Casappa technical sales department for the specific application.

RP1 - LS2 (with flow control)

Not included in supply

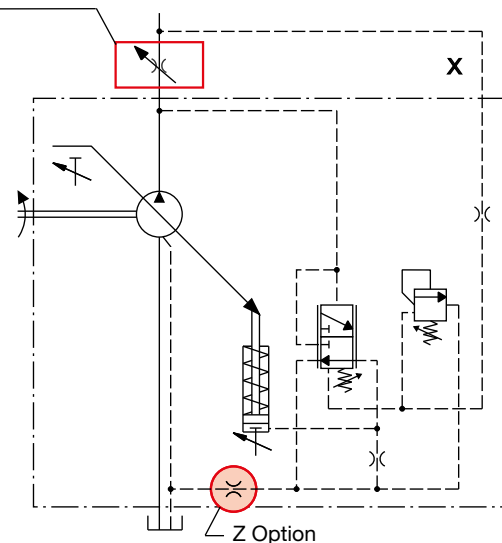

01/04.2022

NOTES

X: Load-sensing port. Dimensions at page 18 ÷ 20. Please contact us for more information.

DUAL SETTING PRESSURE COMPENSATOR

RP2

Regulates the pump displacement automatically to maintain the pressure below two fixed pre-adjusted limits. The electrically piloted valve allows to switch between the two different limits.

OPERATING CURVES

Curves have been obtained at the speed of 1500 min⁻¹ and oil temperature 50 °C (122 °F).

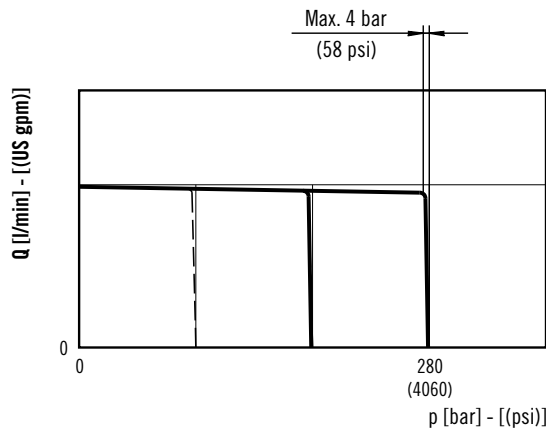

Valve code	Arrangement	Voltage
1	Normally closed	12 V DC
2	Normally closed	24 V DC
6	Normally open	12 V DC
7	Normally open	24 V DC

RP2

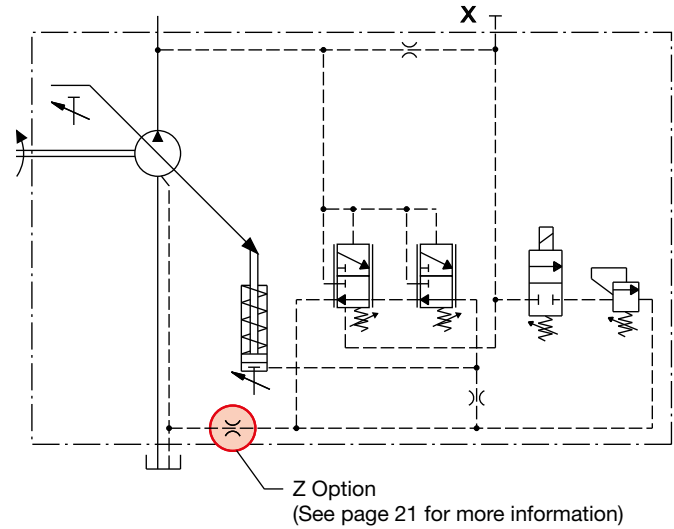

RP2 - LS2 (with flow control)

Not included in supply

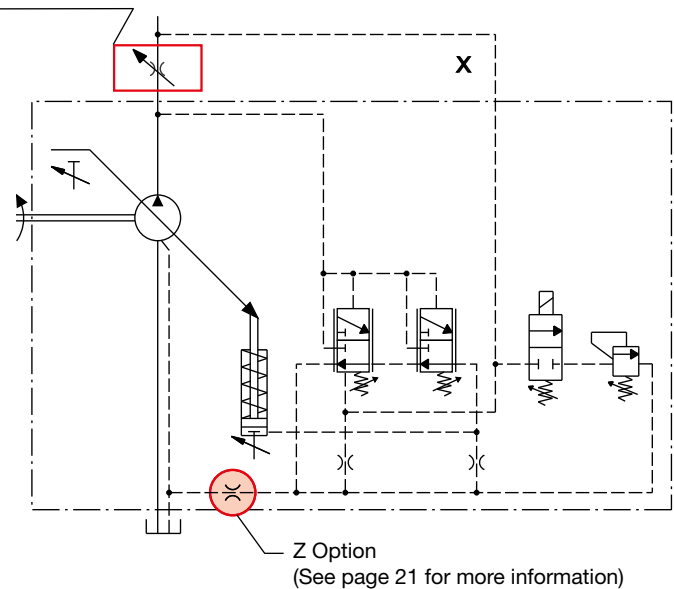

01/04.2022

NOTES

X: Load-sensing port. Dimensions at page 18 ÷ 20.
Connector: Standard type DIN 43650.
Please contact us for other connectors and more information.

PRESSURE ELECTRONIC COMPENSATOR

PEC

Regulates the pump displacement automatically to maintain the pressure below the variable limit set through a command current signal.

OPERATING CURVES

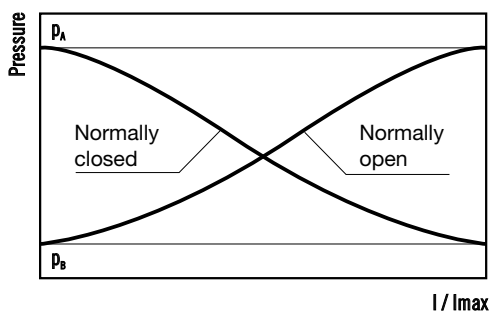

VALVE FEATURES

Valve code	Arrangement	Voltage
1	Normally closed	12 V DC
2	Normally closed	24 V DC
6	Normally open	12 V DC
7	Normally open	24 V DC

Connector type	DIN 43650/		DEUTSCH DT04-2P	
	12 V DC	24 V DC	12 V DC	24 V DC
Voltage	12 V DC	24 V DC	12 V DC	24 V DC
Power	18 W	19 W	18 W	19 W
Resistance @ 20 °C (68 °F)	8 Ω	30 Ω	8 Ω	30 Ω
Limit current	1500 mA	800 mA	1500 mA	800 mA
Dither frequency	200 Hz			
Operating temperature	-40 ÷ 100 °C (-40 ÷ 212 °F)			

01/04.2022

NOTES

X: Load-sensing port. Dimensions at page 18 ÷ 20.
Please contact us for more information.

PEC

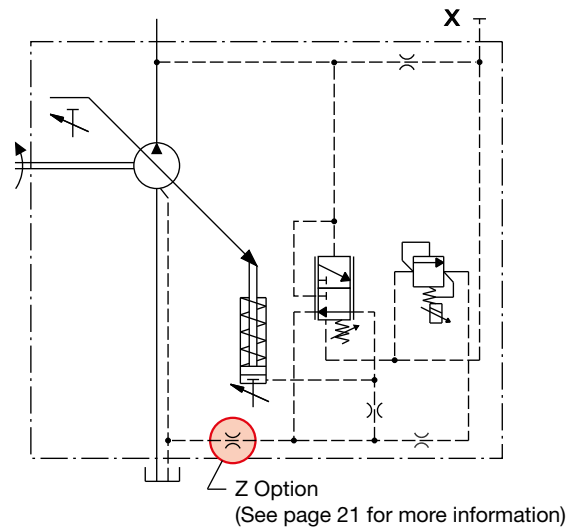

PEC - LS2 (with flow control)

Not included in supply

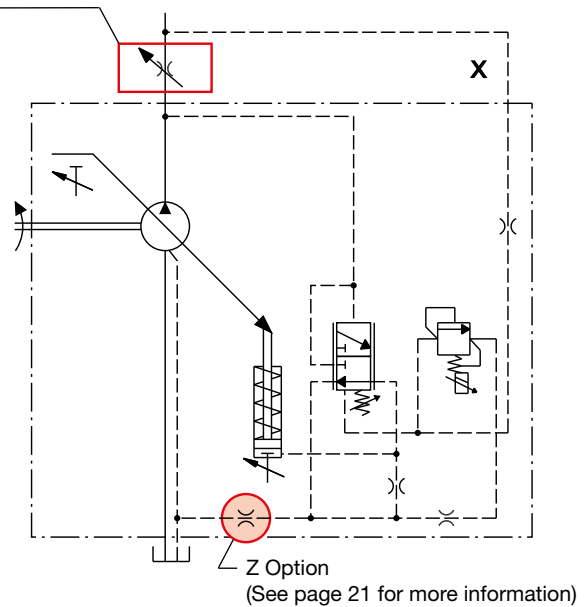

PRESSURE ELECTRONIC COMPENSATOR PLUS ANGULAR SENSOR

PECA

Regulates the pump displacement automatically to maintain the pressure below the variable limit set through a command current signal. The swivel angular sensor converts the actual position of the swashplate into a voltage output signal that can be used for different purposes. This signal and the proportional relief valve allow to realise the following different control logics by means of an external control unit:

- Variable maximum pressure limiter
- Electronic flow compensator with variable setting (variable Load-Sensing)
- Electronic torque limiter with variable torque setting
- Power limiter
- Flow control
- Working e-modes

OPERATING CURVES

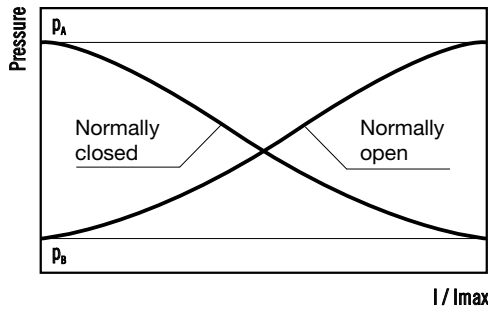

VALVE FEATURES

Valve code	Arrangement	Voltage
1	Normally closed	12 V DC
2	Normally closed	24 V DC
6	Normally open	12 V DC
7	Normally open	24 V DC

Connector type	DIN 43650		DEUTSCH DT04-2P	
	12 V DC	24 V DC	12 V DC	24 V DC
Voltage	12 V DC	24 V DC	12 V DC	24 V DC
Power W	18 W	19 W	18 W	19 W
Resistance @ 20 °C (68 °F)	8 Ω	30 Ω	8 Ω	30 Ω
Limit current	1500 mA	800 mA	1500 mA	800 mA
Dither frequency	200 Hz			
Operating temperature	-40 ÷ 100 °C (-40 ÷ 212 °F)			
Angular sensor connector type	DEUTSCH DTM04-4P			

NOTES

X: Load-sensing port. Dimensions at page 18 ÷ 20. Please contact us for more information.

PECA

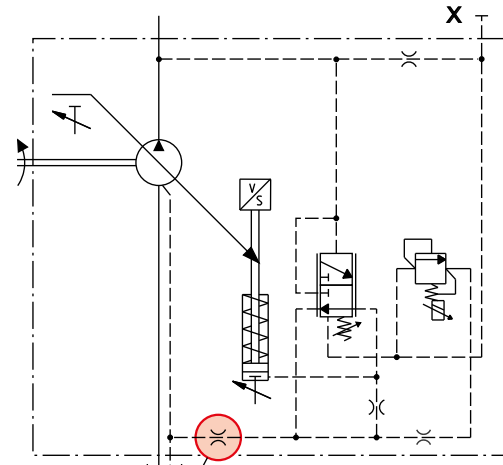

Z Option
(See page 21 for more information)

PECA - LS2 (with flow control)

Not included in supply

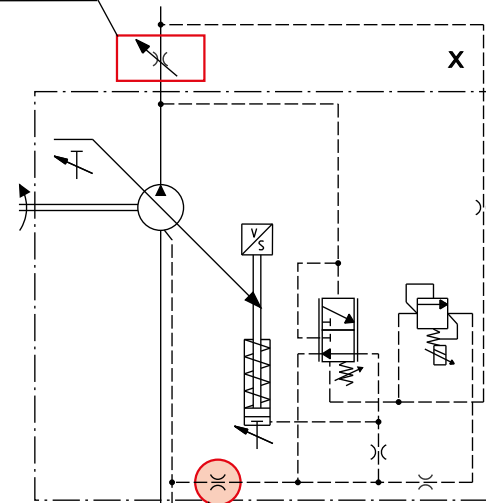

Z Option
(See page 21 for more information)

ANGULAR SENSOR

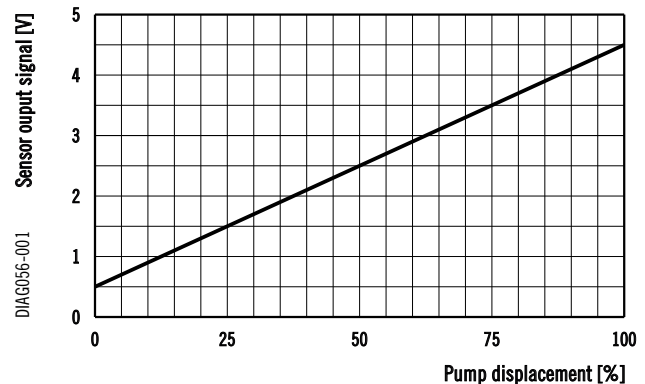

DIAG056-001

01/04.2022

FLOW COMPENSATOR (Load-sensing)

LS

Regulates the pump displacement to maintain a constant (load independent) pressure drop across a flow metering device. In the standard version the flow compensator is combined with pressure compensator.

Flow compensator type	Pressure compensator	Differential pressure setting range bar (psi)	Standard setting bar (psi)
LS0 (■)	RPO		
LS2 (◆)	RPO	12 ÷ 40 (174 ÷ 580)	14 (203)
LS3 (●)	RPO		

- (■): Suggested when the directional control valve does not have the bleed function
- (◆): Y is plugged. Suggested when the directional control valve has the bleed function
- (●): For remote pressure control.

Pilot flow ≈ 1,3 ÷ 1,5 l/min (0.34 ÷ 0.40 US gpm)

In standard setting conditions 14 bar (203 psi) the stand-by pressure is 15^{±2} bar (218^{±29} psi).

OPERATING CURVES

Curves have been obtained at the speed of 1500 min⁻¹ and oil temperature 50 °C (122 °F).

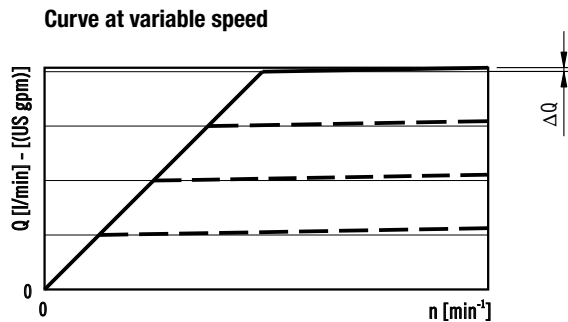

RESPONSE TIME

According to SAE J745 (using outlet pressure).

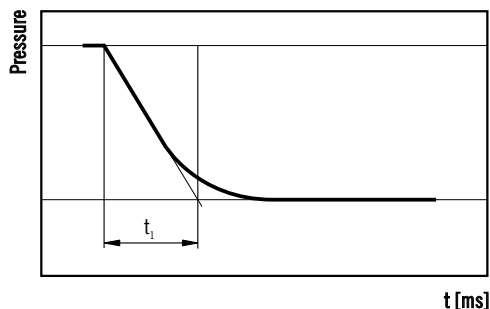

NOTES

X: Load-sensing port. Dimensions at page 18 ÷ 20.
Available without pressure compensator RP.
Please contact us for more information.

LS0 (Bleed open) - LS2 (Bleed closed)

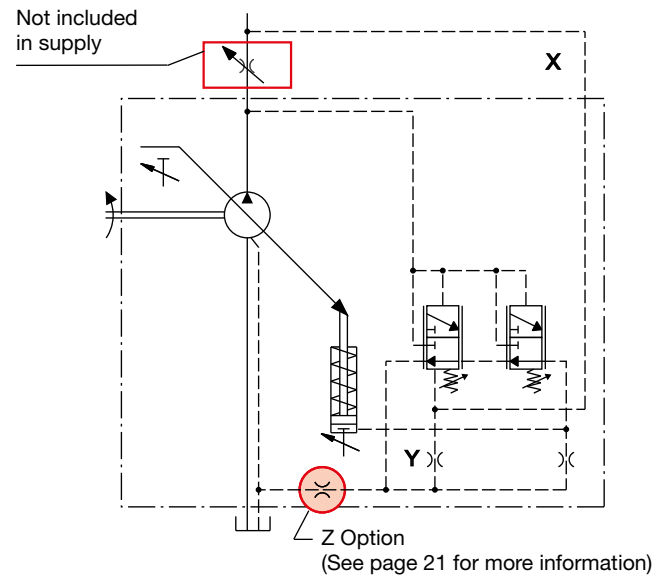

LS3 - Remote pressure compensator

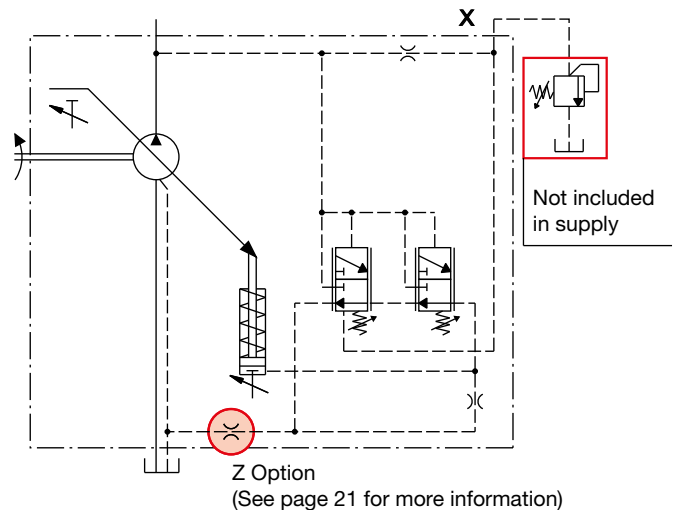

ΔQ max

Pump type	l/min (US gpm)
MVPR60	2,5 (0.66)

t₁

Pump type	Response time [ms] (off stroke)
MVPR60	120

According to SAE J745 (using outlet pressure)

01/04.2022

TORQUE LIMITER

RN

Regulates the pump displacement according to the system pressure, to maintain the pre-adjusted torque value and protect the prime mover from overload. To have the best torque limiter regulation, the pre-adjusted absorbed torque has to be higher than the value shown in the following table.

Pump type	Min. torque	Min. power (●)
	Nm (lbf in)	kW (HP)
MVPR60	97 (859)	15.2 (20,4)

(●) @ 1500 min⁻¹

For lower torque setting values, the regulator limits the maximum working pressure to a value lower than the standard setting for the pressure regulator 280 bar (4060 psi). When ordering the torque limiter please specify the requested value of torque [eg. 70 Nm (620 lbf in)] or the requested power and speed [eg. 10 kW (13.4 HP) at 1500 min⁻¹].

OPERATING CURVES

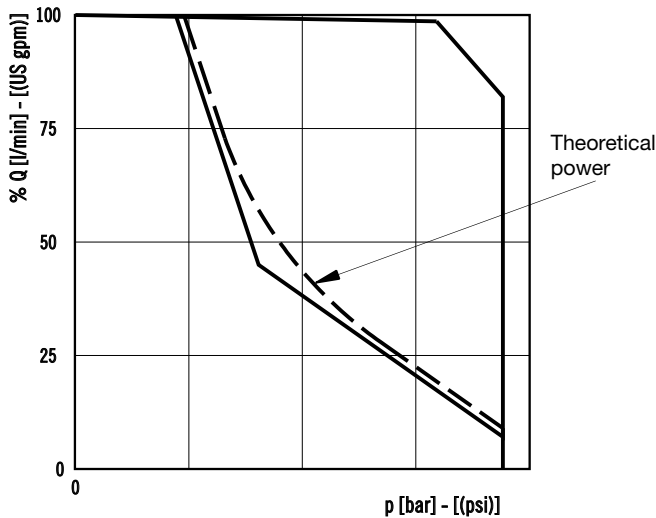

NOTES

X: Load-sensing port. Dimensions at page 18 ÷ 20.
Available without pressure compensator RP.
Please contact us for more information.

RN0 - Standard

Torque limitation for closed center valve.

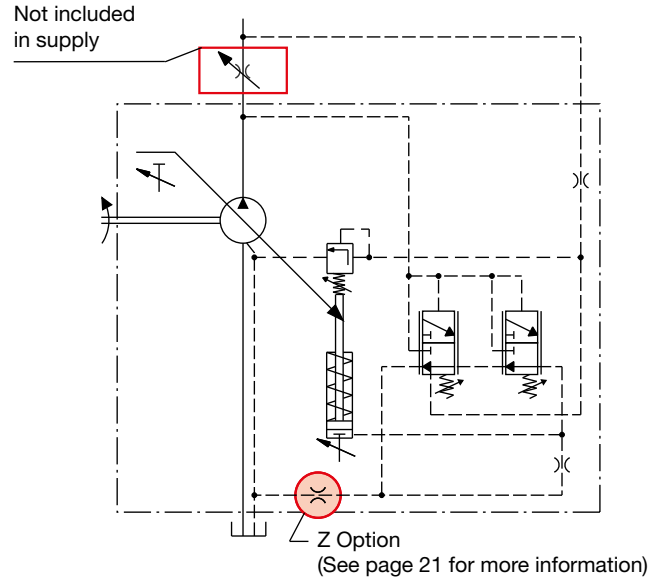

RN1 - Internal pilot

Torque limitation for open center valve.

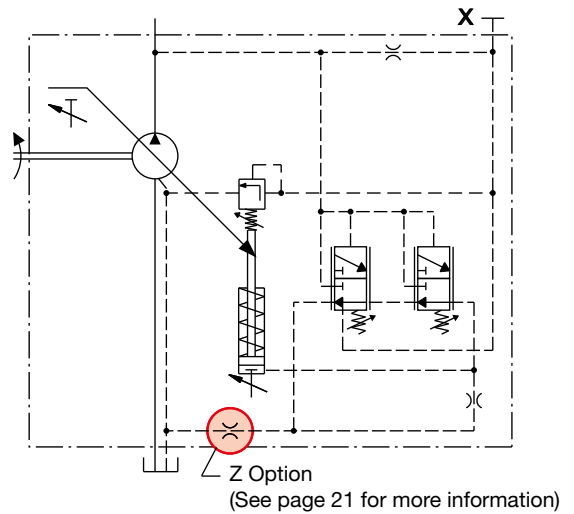

01/04.2022

DUAL SETTING TORQUE LIMITER

RN2

Regulates the pump displacement automatically to maintain the torque below two fixed pre-adjusted limits. The electrically piloted valve allows to switch between the two different limits.

RN2-LS0 / RN2-LS2

For LS2 configuration Y is plugged.

Pump type	Min. torque	Min. power (●)
	Nm (lbf in)	kW (HP)
MVPR60	97 (859)	15.2 (20,4)

(●) @ 1500 min⁻¹

For lower torque setting values, the regulator limits the maximum working pressure to a value lower than the standard setting for the pressure regulator 280 bar (4060 psi).

When ordering the torque limiter please specify the requested value of torque [eg. 70 Nm (620 lbf in)] or the requested power and speed [eg. 10 kW (13.4 HP) at 1500 min⁻¹].

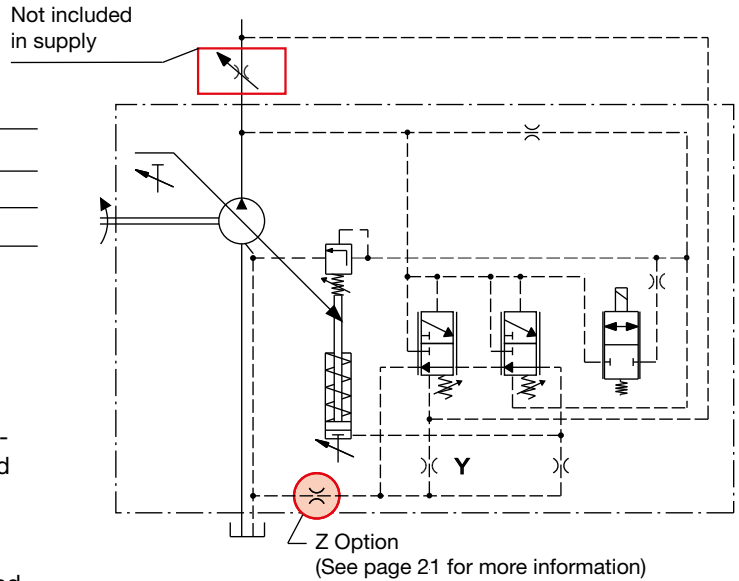

OPERATING CURVES

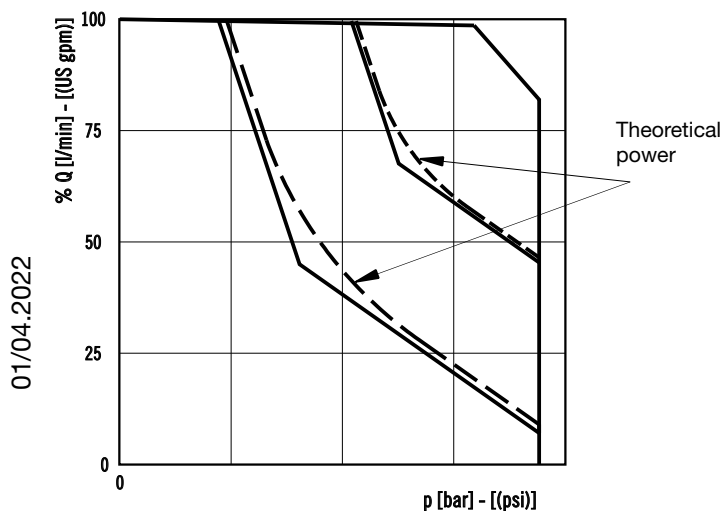

VALVE FEATURES

Valve code	Arrangement	Voltage
1	Normally closed	12 V DC
2	Normally closed	24 V DC
6	Normally open	12 V DC
7	Normally open	24 V DC

Connector type	DIN 43650 DEUTSCH DT04-2P
----------------	------------------------------

NOTES

X: Load-sensing port. Dimensions at page 18 ÷ 20. Please contact us for more information.

HIGH PERFORMANCE TORQUE LIMITER

RN3

Regulates the pump displacement according to the system pressure, to maintain the pre-adjusted torque value and protect the prime mover from overload.

This version is optimized for LS systems. With the standard torque limiter RN0, in case of a high flow through the LS main valve the torque absorbed by the pump can be slightly lower than the pre-adjusted torque value, resulting in a lower flow. The RN3 version grants the pre-adjusted torque value even at high flow through the LS main valve.

To have the best torque limiter regulation, the pre-adjusted absorbed torque has to be higher than the value shown in the following table.

Pump type	Min. torque	Min. power (●)
	Nm (lbf in)	kW (HP)
MVPR60	97 (859)	15.2 (20,4)

(●) @ 1500 min⁻¹

For lower torque setting values, the regulator limits the maximum working pressure to a value lower than the standard setting for the pressure regulator 280 bar (4060 psi).

When ordering the torque limiter please specify the requested value of torque [eg. 70 Nm (620 lbf in)] or the requested power and speed [eg. 10 kW (13.4 HP) at 1500 min⁻¹].

RN3 - Special version

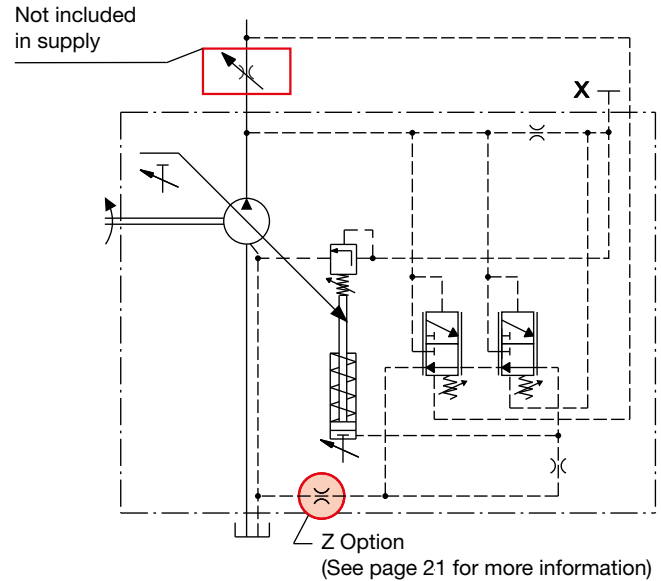

OPERATING CURVES

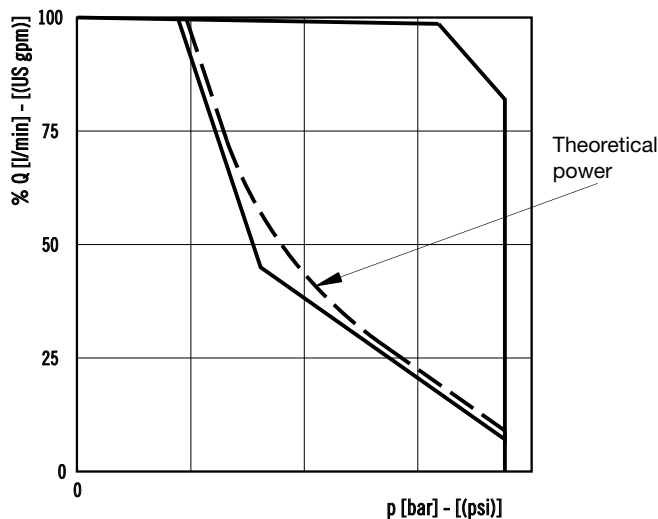

NOTES

X: Load-sensing port. Dimensions at page 18 ÷ 20.
Available with or without pressure compensator RP.
Please contact us for more information.

01/04.2022

UNLOADING VALVE

U..

NC (normally closed)

NA (normally open)

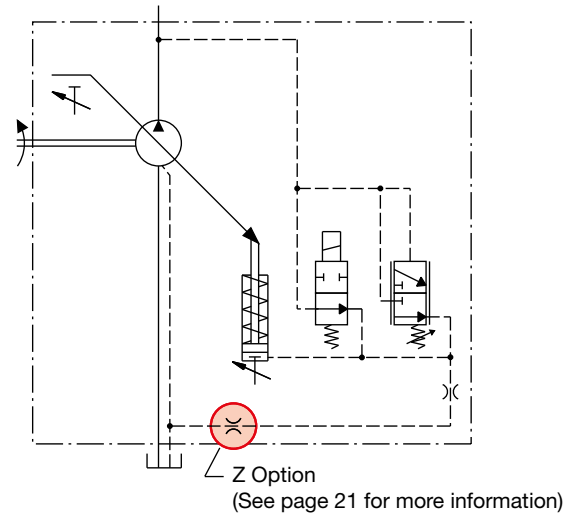
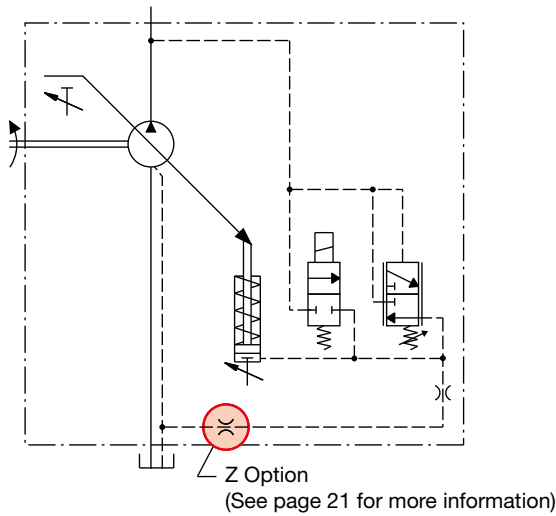

With the valve NC type (normally closed), energizing the solenoid valve the displacement is reset and the pump is unloaded.

With the valve NA type (normally open), energizing the solenoid valve the pump works at the maximum displacement.

VALVE FEATURES

Valve code	Arrangement	Voltage
U1	Normally closed	12 V DC
U2	Normally closed	24 V DC
U6	Normally open	12 V DC
U7	Normally open	24 V DC

01/04.2022

NOTES

Available without pressure compensator RP.
Connector type: DIN 43650.
Please contact us for other connectors and more information.

ELECTRO-PROPORTIONAL DISPLACEMENT COMPENSATOR

DEC

Regulates the pump displacement automatically to maintain it below the variable limit set through a command current signal.

DEC

OPERATING CURVES

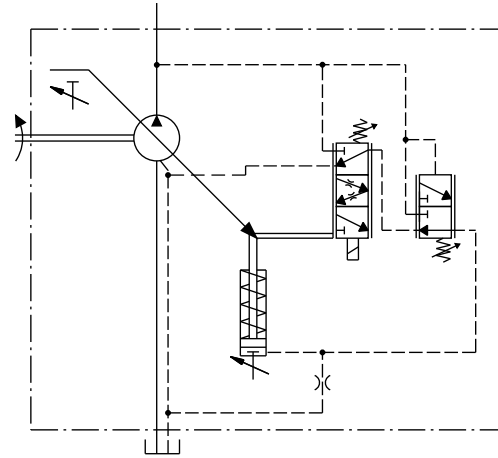
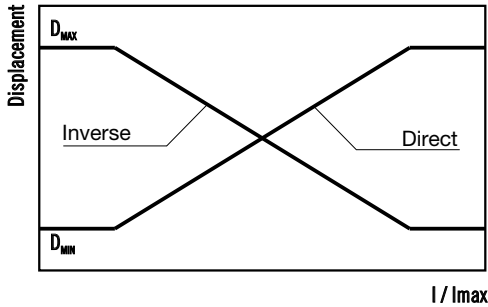

VALVE FEATURES

Valve code	Arrangement	Voltage
1	Inverse	12 V DC
2	Inverse	24 V DC
6	Direct	12 V DC
7	Direct	24 V DC

Connector type	DIN 43 650		DEUTSCH DT04-2P	
	12 V DC	24 V DC	12 V DC	24 V DC
Power	33 W		33 W	
Resistance @ 20 °C (68 °F)	4,4 Ω	17,4 Ω	4,3 Ω	17,5 Ω
Limit current	1700 mA	850 mA	1700 mA	850 mA
Dither frequency	150 Hz		150 Hz	
Operating temperature	-40 ÷ 100 °C (-40 ÷ 212 °F)		-40 ÷ 100 °C (-40 ÷ 212 °F)	

01/04.2022

MULTIPLE PUMPS WITH THROUGH DRIVE

THROUGH DRIVE

MVPR through drive axial piston pumps offer the flexibility to obtain different groups able to supply several hydraulic systems. The operating characteristics of each assembled pumps are the same as the corresponding single pumps according to the following conditions:

- 1) Do not exceed the maximum transmissible torque.
- 2) The maximum rotational speed is that of the lowest rated speed of the single unit incorporated.

M	Nm (lbf in)	Torque
V	cm ³ /rev (in ³ /rev)	Displacement
Δp	bar (psi)	Pressure
$\eta_{hm} = \eta_{hm}(V, \Delta p, n)$		Hydro-mechanical efficiency

$$M = \frac{\Delta p \text{ (bar)} \cdot V \text{ (cm}^3\text{/rev)}}{62,83 \cdot \eta_{hm}} \quad [\text{Nm}]$$

Notes: The torque absorbed from the shaft of the first pump results from the sum of the torques due to all the single stages. The achieved value must not exceed the maximum torque limit given for the shaft of the first pump.

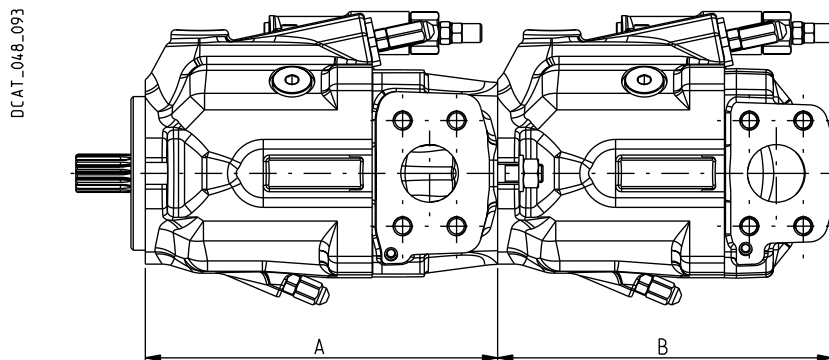

A: Front section (through drive)

B: MVPR Rear pump (the same of single pump with side or rear ports)

Gear rear pump are also available, please see the respective technical catalogues.

01/04.2022

A		
Pump type	Flanged for	Code
MVPR60	SAE B	AS5

MVPR60

FRONT SECTION - DIMENSIONS

AS5

Through drive SAE B

Drive shafts: see page 15
Mounting flanges: see page 16 ÷ 17
Ports: see page 18 ÷ 20

The drawing shows a front section with clockwise rotation

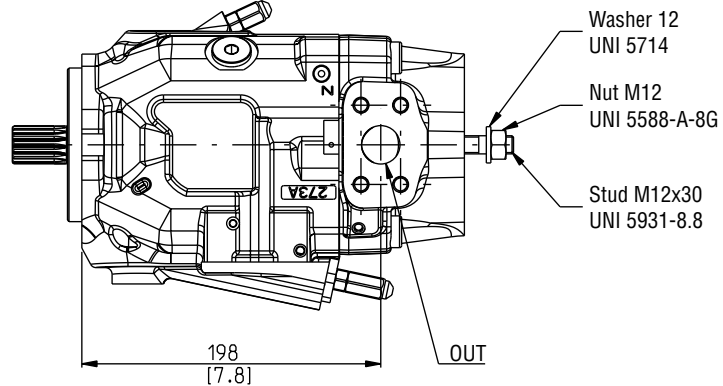
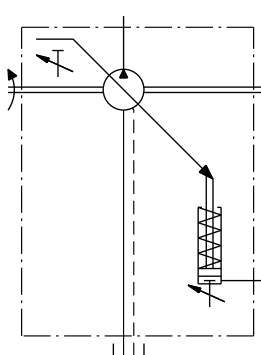
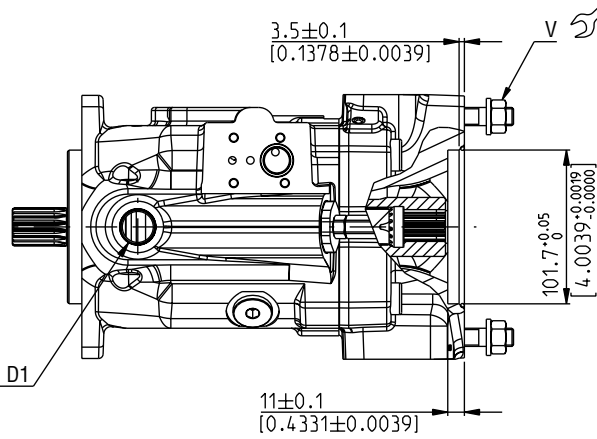
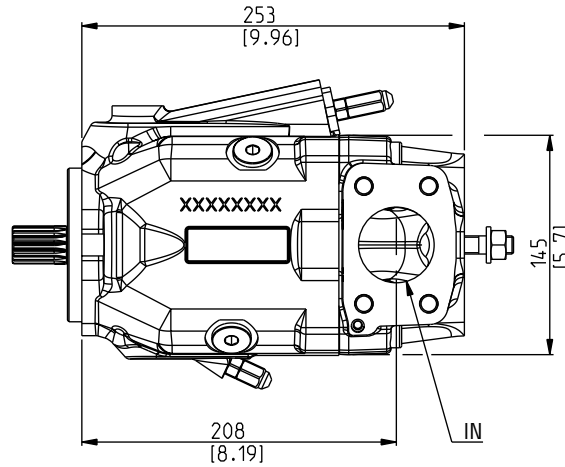
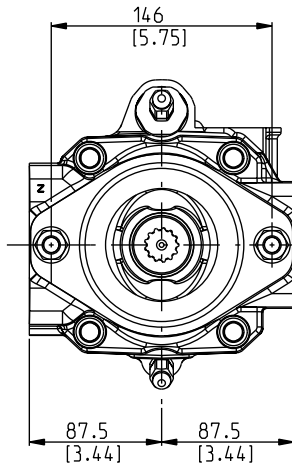

Screws tightening torque Nm (lbf in)

V
100 ±10 (797 ÷ 974)

DCAT_048_040

01/04.2022

MVPR60

COUPLINGS - DIMENSIONS

SAE "B" SPLINE

04

Available with flange code **AS5**

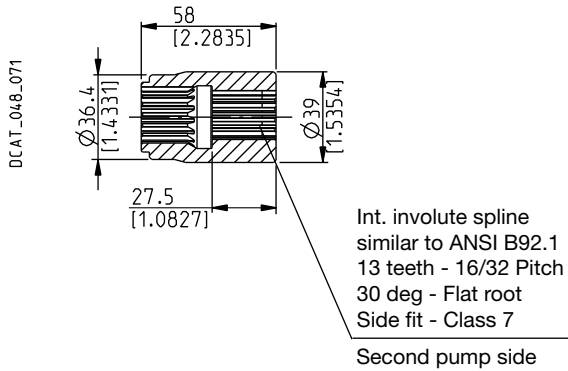

MAX 200 Nm (1770 lbf in)

SAE "BB" SPLINE

05

Available with flange code **AS5**

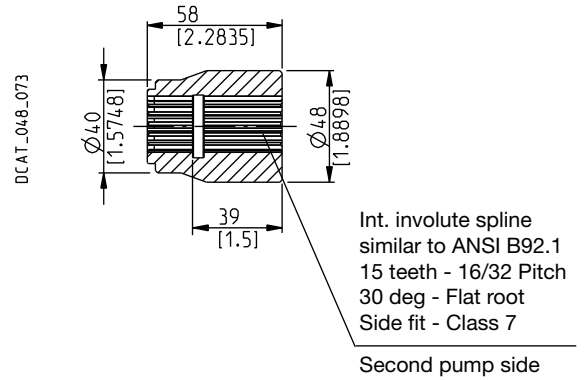

MAX 250 Nm (2213 lbf in)

SAE "C" SPLINE

06

Available with flange code **AS5**

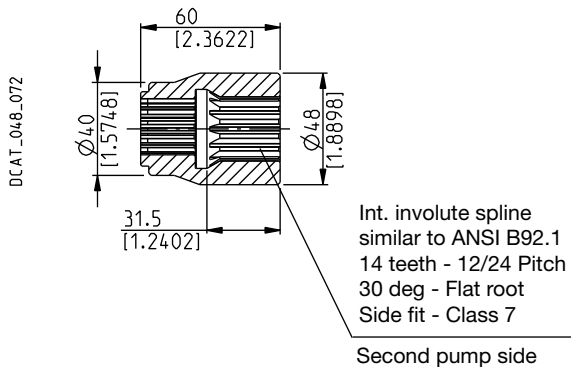

MAX 430 Nm (3806 lbf in)

01/04.2022

FRONT SECTION KIT COVER

Kit cover is available to obtain single pumps starting from the front sections of multiple pumps.
Before closing the intermediate flange check that the coupling has been removed.

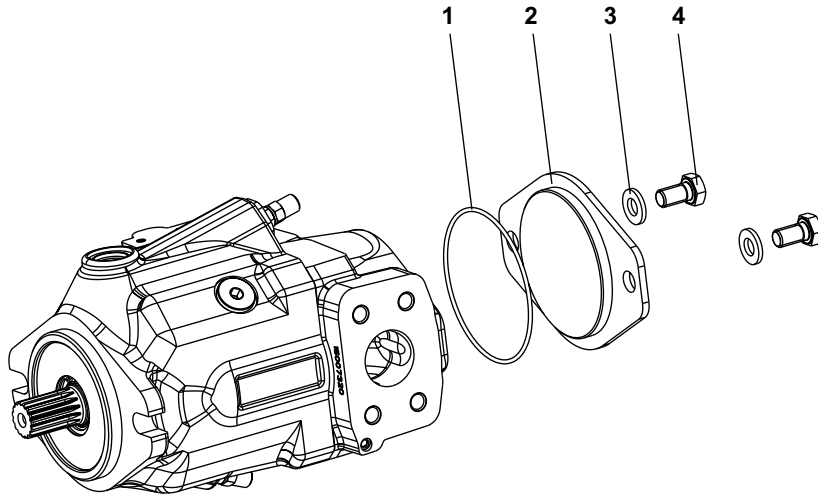

Kit part brake down

- 1 - Seal
- 2 - Flange
- 3 - Washers
- 4 - Screws

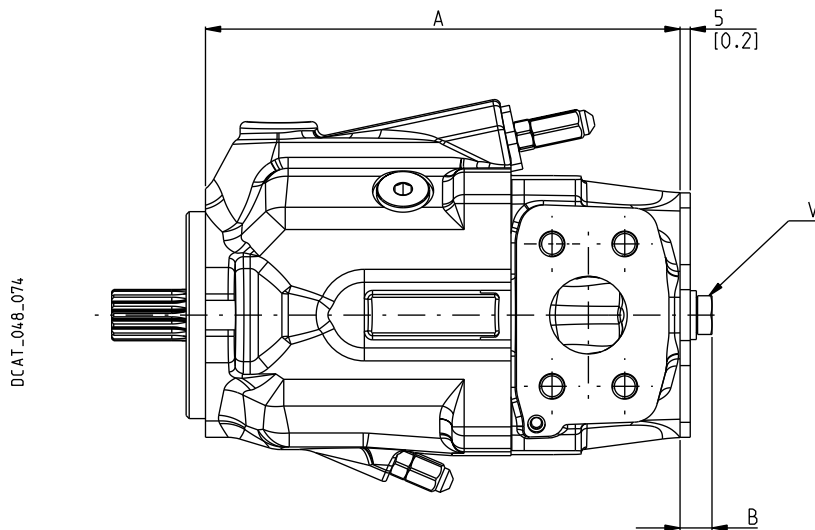

DCAT_048_074

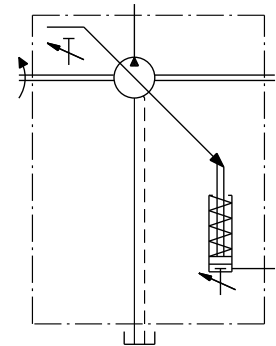

01/04.2022

		Front section			Kit cover
Pump type	Flanged for	Code	A mm (in)	B mm (in)	Code
MVPR60	SAE B	AS5	253 (9.9606)	16 (0.6299)	6210007

Screws tightening torque Nm (lbf in)

V
20 ±1 (159 ÷ 195)

HOW TO ORDER SINGLE PUMPS

1	2	3	4	5	6	7	8 ...
MVPR60-60	S	-	04	S5	-	L	MD/MB - N - ...

1	Pump type (max. displacement)	Code
	60 cm ³ /rev (3.66 in ³ /rev)	MVPR60-60
	72 cm ³ /rev (4.39 in ³ /rev)	MVPR60-72
	84,7 cm ³ /rev (5.17 in ³ /rev)	MVPR60-84

2	Rotation	Code
	Anti-clockwise	S
	Clockwise	D

3	Drive shaft (a)	Code
	SAE "B" spline (13 teeth)	04
	SAE "BB" spline (15 teeth)	05
	SAE "BB" spline (15 teeth)	5R
	SAE "C" spline (14 teeth)	06
	SAE "C" spline (14 teeth)	6R
	SAE "B" straight	34

4	Mounting flange (a)	Code
	SAE "B" 2 holes	S5
	SAE "C" 2 holes	S7
	SAE "C" 4 holes	S8

5	Ports position	Code
	Side	L
	Rear	P

Code	Inlet/outlet ports		6
	Nominal size		
	Inlet IN	Outlet OUT	Pump type
	SAE 3000	SAE 3000	
SAE FLANGED PORTS METRIC THREAD (SSM)			
MF/MC	2"	1"	MVPR60
SAE FLANGED PORTS UNC THREAD (SSS)			
SF/SC	2"	1"	MVPR60
SAE STRAIGHT THREAD PORTS (ODT)			
MF/OF	2"	1"	MVPR60

Code	Seals	7
N	Buna (standard)	
V	Viton	

Code	Regulators	8
...	See how to order on page 37 ÷ 39	

01/04.2022

(a) Drive shafts availability at page 15 and mounting flanges availability at pages 16 ÷ 17

HOW TO ORDER REGULATORS

PRESSURE COMPENSATORS - FLOW COMPENSATORS (Load-sensing)

Replaces: 06/06.2020	Pressure compensator	8	9	10	11	12	13	14
		RP1	-		Z	-	G	DP
	Pressure compensator with flow control	RP1	-	LS2	Z	-	G	DP
	Dual setting pressure compensator	RP2	1	-	Z	S	G	DP
	Dual setting pressure compensator with flow control	RP2	1	LS2	Z	S	G	DP
	Flow compensator	LS0	-		Z	-	G	DP
	Flow compensator for remote control	LS2	-		Z	-	G	DP
Pressure compensator for remote control	LS3	-		Z	-	G	DP	

8	Regulators type	Code
	Pressure compensator	RP1
	Dual setting pressure compensator	RP2
	Flow compensator	LS0
	Flow compensator for remote control	LS2
	Pressure compensator for remote control	LS3

9	Valve type	Code
	Normally closed 12 V DC	1
	Normally closed 24 V DC	2
	Normally open 12 V DC	6
	Normally open 24 V DC	7

Code	Flow control option	10
LS2	Flow compensator	

Code	Restrictor option	11
	Without restrictor (standard - no code)	
Z	Damping restrictor (only for critical applications)	

Code	Connector type	12
S	DIN 43650 (standard)	
D	Deutsch DT04-2P	

Code	Displacement limiter	13
E	Max. displacement limiter	
G	Min. and Max. displacement limiter	

Code	Double shaft seal option	14
	Without double shaft seal (standard - no code)	
DP	Double shaft seal (availability at page 9)	

01/04.2022

ORDER EXAMPLE

MVPR60 pump with dual setting pressure compensator:
MVPR60.60S-05S5-LMF/MC-N-RP2-1-S-G-DP

HOW TO ORDER REGULATORS

ELECTRO-PROPORTIONAL PRESSURE AND DISPLACEMENT COMPENSATORS - UNLOADING VALVES

	8	9	10	11	12	13	14	15	16	17	
Pressure electronic compensator	PEC	1	A	-		...	/	...	D	G	DP
Pressure electronic compensator with flow control	PEC	1	A	LS2	-	...	/	...	D	G	DP
Pressure electronic compensator plus angular sensor	PECA	1	A	-		...		D	G	DP	
Pressure electronic compensator plus angular sensor with flow control	PECA	1	A	LS2	-	...		D	G	DP	
Unloading valve	U..				Z				G	DP	
Electro-proportional displacement compensator	DEC	1			LS2			D	G	DP	

8	Regulators type	Code
	Pressure electronic compensator	PEC
	Pressure electronic compensator and swashplate angular sensor	PECA
	Unloading valve - Normally closed 12 V DC	U1
	Unloading valve - Normally closed 24 V DC	U2
	Unloading valve - Normally open 12 V DC	U6
	Unloading valve - Normally open 24 V DC	U7
	Electro-proportional displacement compensator	DEC

9	Valve type	Code
	Normally closed 12 V DC	1
	Normally closed 24 V DC	2
	Normally open 12 V DC	6
	Normally open 24 V DC	7

10	Position	Code
	Position 0°	A
	Position 90°	B

11	Flow control option	Code
	Flow compensator for remote control	LS2

Code	Restrictor option	12
	Without restrictor (standard - no code)	
Z	Damping restrictor (only for critical applications)	

Code	Min. pressure setting	13
...	Please specify the requested value in bar	

Code	Max. pressure setting	14
...	Please specify the requested value in bar	

Code	Connector type	15
S	DIN 43650	
D	Deutsch DT04-2P	

Code	Displacement limiter	16
E	Max. displacement limiter	
G	Min. and Max. displacement limiter	

Code	Double shaft seal option	17
	Without double shaft seal (standard - no code)	
DP	Double shaft seal (availability at page 9)	

01/04.2022

ORDER EXAMPLE

MVPR60 pump with pressure electronic compensator with flow control:

MVPR60.60S-05S5-LMF/MC-N-PEC-1-A-LS2-100/300-D-G-DP

HOW TO ORDER REGULATORS

TORQUE LIMITERS

	8	9	10	11	12	13	14	15	16	17									
Torque limiter - standard	RN0	-				Z	-	G	-	DP	-	...	/			...			
Torque limiter - internal pilot	RN1	-				Z	-	G	-	DP	-	...	/			...			
Dual setting torque limiter with flow control	RN2	-	1	-	S	-	LS0	-	Z	-	G	-	DP	-	...	/	...	/	...
Dual setting torque limiter with remote flow control	RN2	-	1	-	S	-	LS2	-	Z	-	G	-	DP	-	...	/	...	/	...
High performance torque limiter	RN3	-				Z	-	G	-	DP	-	...	/			...			

8	Regulators type	Code
	Torque limiter - standard	RN0
	Torque limiter - internal pilot	RN1
	Dual setting torque limiter with flow control	RN2
	High performance torque limiter	RN3

9	Valve type	Code
	Normally closed 12 V DC	1
	Normally closed 24 V DC	2
	Normally open 12 V DC	6
	Normally open 24 V DC	7

10	Connector type	Code
	DIN 43650 (standard)	S
	Deutsch DT04-2P	D

11	Flow control option	Code
	Flow compensator	LS0
	Flow compensator for remote control	LS2

12	Restrictor option	Code
	Without restrictor (standard - no code)	
	Damping restrictor (only for critical applications)	Z

Code	Displacement limiter	13
E	Max. displacement limiter	
G	Min. and Max. displacement limiter	

Code	Double shaft seal option	14
	Without double shaft seal (standard - no code)	
DP	Double shaft seal (availability at page 9)	

Code	Torque limiter setting (a)	15
...	Please specify the requested torque value in Nm	

Code	Second torque limiter setting (a)	16
...	Please specify the requested torque value in Nm	

Code	Torque limiter setting speed (b)	17
...	Please specify the requested speed value	

- (a) Refer to page 26 ÷ 28 for more information
 (b) Do not exceed the maximum speed shown on page 7

01/04.2022

ORDER EXAMPLE

MVPR60 pump with dual setting torque limiter with flow control:

MVPR60.60S-05S5-LMF/MC-N-RN2-1-S-LS0-Z-G-DP-150/200/2100

HOW TO ORDER MULTIPLE PUMPS - PISTON PUMP/GEAR PUMP

Common inlet

1	2	3	4	5	6	7	8 ...	9	10	11	7	12	13	14	15												
MVPR60-60	S	-	04	S5	-	L	MF/MC	-	N	-	...	-	G	-	DP	-	P7	-	A	(# / # / #) /							
Front section																											
Rear section																											
<table border="1"> <tr> <td>KP20-6,3</td><td>S</td><td>-</td><td>-</td><td>L</td><td>**/GD</td><td>-</td><td>N5</td><td>-</td><td>N</td><td>-</td><td>P</td> </tr> </table>																KP20-6,3	S	-	-	L	**/GD	-	N5	-	N	-	P
KP20-6,3	S	-	-	L	**/GD	-	N5	-	N	-	P																

1	Pump type (max. displacement)	Code
Front section - The same of single pumps		MVPR ...
Rear section - KAPPA 20 gear pumps (a)		KP 20 ...
Rear section - POLARIS PH gear pumps (b)		PHP 20 ...

2	Rotation	Code
Anti-clockwise		S
Clockwise		D

3	Drive shaft (c)	Code
SAE "B" spline (13 teeth)		04
SAE "BB" spline (15 teeth)		05
SAE "BB" spline (15 teeth)		5R
SAE "C" spline (14 teeth)		06
SAE "C" spline (14 teeth)		6R
SAE "C" straight		34

4	Mounting flange (c)	Code
SAE "B" 2 holes		S5
SAE "C" 2 holes		S7
SAE "C" 4 holes		S8

5	Ports position	Code
Side		L

6	Inlet/outlet ports (a) - (b)	Code	
Nominal size			
Pump type	Inlet IN	Outlet OUT	
	SAE 3000	SAE 6000	
SAE FLANGED PORTS METRIC THREAD (SSM)			
MVPR60	2"	1" 1/4	MF/MC

Code	Inlet/outlet ports	6	
Nominal size			
	Inlet IN	Outlet OUT	Pump type
	SAE 3000	SAE 3000	

SAE FLANGED PORTS UNC THREAD (SSS)			
SF/SC	2"	1"	MVPR60
SAE STRAIGHT THREAD PORTS (ODT)			
MF/OF	2"	1"	MVPR60

Code	Seals	7
N	Buna (standard)	
V	Viton	

Code	Regulators	8
...	See how to order on page 37 ÷ 39	

Code	Displacement limiter	9
E	Max. displacement limiter	
G	Min. and Max. displacement limiter	

Code	Double shaft seal option	10
Without double shaft seal (standard - no code)		
DP	Double shaft seal (availability at page 9)	

Code	Intermediate flange	11
FRONT SECTION		
P7	Flanged for KP20	
I7	Flanged for PHP20	
REAR SECTION		
N5	Kappa 20 (common inlet)	
S7	Polaris PHP 20 (common inlet)	

Code	Sections	12
A	Front	
P	Rear	

01/04.2022

HOW TO ORDER MULTIPLE PUMPS - PISTON PUMP/GEAR PUMP

Code	Torque limiter setting (#)	13
...	Please specify the requested torque value in Nm	
Code	Second torque limiter setting (#)	14
...	Please specify the requested torque value in Nm	
Code	Torque limiter setting speed (#)	15
...	Please specify the requested speed value	

- Omit code only if ordering assembled multiple pumps
- (#) Only for torque limiter. Refer to page 26 ÷ 28 for more information.
Write these codes at the end only if ordering assembled multiple pumps
- (a) KAPPA 20 gear pumps: displacements on page 13. For more information, please see the respective technical catalogue
- (b) POLARIS PH gear pumps displacements on page 14. For more information, please see the respective technical catalogue
- (c) Drive shafts availability at pages 15 and mounting flanges availability at pages 16 ÷ 17

ORDER EXAMPLE

Common inlet double pump MVPR60 with RN1 torque limiter-internal pilot + PHP20 gear pump.

INDIVIDUAL SECTIONS

Front section

MVPR60.60S-06S8-LMF/MC-N-RN1-G-DP-I7-A (100/2500)

Rear section

PHP 20.23S-L **/GD-S7-N-P

ASSEMBLED DOUBLE PUMP

MVPR60.60S-06S8-LMF/MC-N-RN1-G-DP/PHP 20.23-L/GD (100/2500)**

HOW TO ORDER MULTIPLE PUMPS - PISTON PUMP/PISTON PUMP

Through drive

1	2	3	4	5	6	7	8 ...	9	10	11	12	13	14	15
MVPR60-60	S	- 06	S8	- L	MF/MC	- N	- ...	- G	- AS5	- 04	- DP	(# / # / #)	/	

Front section (through drive)

MVPR60-60	S	- 04	S5	- L	MF/MC	- N	- ...	- G	-					
-----------	---	------	----	-----	-------	-----	-------	-----	---	--	--	--	--	--

Rear section (single pump)

1	Pump type (max. displacement)	Code
	Front section MVPR (the same of single pumps) (a)	MVPR ...
	Rear section MVPR (the same of single pumps) (a)	MVPR ...

2	Rotation	Code
	Anti-clockwise	S
	Clockwise	D

3	Drive shaft (b)	Code
	SAE "B" spline (13 teeth)	04
	SAE "BB" spline (15 teeth)	05
	SAE "BB" spline (15 teeth)	5R
	SAE "C" spline (14 teeth)	06
	SAE "C" spline (14 teeth)	6R
	SAE "C" straight	34

4	Mounting flange (b)	Code
	SAE "B" 2 holes	S5
	SAE "C" 2 holes	S7
	SAE "C" 4 holes	S8

5	Ports position	Code
	Side	L

6	Inlet/outlet ports	Code
	Pump type	Nominal size
		Inlet IN Outlet OUT
		SAE 3000 SAE 6000
	SAE FLANGED PORTS METRIC THREAD (SSM)	
	MVPR60	2" 1" 1/4 MF/MC
	SAE FLANGED PORTS UNC THREAD (SSS)	
	MVPR60	2" 1" SF/SC

Code	Inlet/outlet ports	6
	Nominal size	
	Inlet IN Outlet OUT	Pump type
	SAE 3000 SAE 3000	

SAE STRAIGHT THREAD PORTS (ODT)			
MF/OF	2"	1"	MVPR60

Code	Seals	7
N	Buna (standard)	
V	Viton	

Code	Regulators	8
...	See how to order on page 37 ÷ 39	

Code	Displacement limiter	9
E	Max. displacement limiter	
G	Min. and Max. displacement limiter	

Code	Intermediate flange (c)	10
AS5	SAE "B" 2 holes	

Code	Coupling (d)	11
04	SAE "B" spline (13 teeth)	
05	SAE "BB" spline (15 teeth)	
06	SAE "C" spline (14 teeth)	

Code	Double shaft seal option	12
	Without double shaft seal (standard - no code)	
DP	Double shaft seal (availability at page 9)	

Code	Torque limiter setting (#)	13
...	Please specify the requested torque value in Nm	

01/04.2022

HOW TO ORDER MULTIPLE PUMPS - PISTON PUMP/PISTON PUMP

Code	Second torque limiter setting (#)	14
...	Please specify the requested torque value in Nm	

Code	Torque limiter setting speed (#)	15
...	Please specify the requested speed value	

- (a) Displacements on page 36
- (b) Drive shafts availability at page 15 and mounting flanges availability at pages 16 ÷ 17
- (c) Intermediate flanges on page 31
- (d) Couplings availability: MVPR60 on page 33

Omit code only if ordering assembled multiple pumps

- (#) Only for torque limiter. Refer to page 26 ÷ 28 for more information.

ORDER EXAMPLE

Through drive double pump MVPR60 with RN2 (dual setting torque limiter with remote flow control) + MVPR60 with LS0 flow compensator.

INDIVIDUAL SECTIONS

Front section

MVPR60.60S-06S8-LMF/MC-N-RN2-1-S-LS2-G-AS5/04-DP (70/85/2600)

Rear section

MVPR60.60S-04S5-LMF/MC-N-LS0-Z-G

ASSEMBLED DOUBLE PUMP

MVPR60.60S-06S8-LMF/MC-N-RN2-1-S-LS2-G-DP (70/85/2600)/ MVPR6030.60S-04S5-LMD/MB-N-LS0-Z-G

01/04.2022

MVPR 01 T A

Edition: 01/04.2022



Headquarters:
CASAPPA S.p.A.
Via Balestrieri, 1
43044 Lemignano di Collecchio
Parma (Italy)
Tel. (+39) 0521 30 41 11
E-mail: info@casappa.com
www.casappa.com

