

Radial piston pump type R and RG

with radial piston pump acc. to D 6010 and several pressure outlet

Operating pressure $p_{max} = 700$ bar
 Delivery flow $Q_{max} = 76.0$ lpm (at 1450 rpm)

Radial piston pumps type R and RG	D 6010
Radial piston pumps type R and RG with several pressure ports	D 6010 D
Radial piston pumps type R and RG with one main and one or two auxiliary pressure ports	D 6010 S
Motor pumps and hydraulic power packs type R and RG	D 6010 H

1. General

Pumps type R and RG design 6010 to 6016 with several pressure ports, as detailed in pamphlet D 6010 D are available also as ready for use power packs including cover plate, tank, internal pipe work etc. These power packs may come with or without electric motor. Only some of the many delivery flow configurations and pressure port options, as detailed in pamphlet D 6010 D, are available due to design reasons.

All other combinations require a customer furnished tank, cover plate, and ancillaries. Pamphlet D 6010 H, sect. 6.2 lists all available bellhousings, couplings, and suction parts.

For all general technical data not covered here, refer to D 6010 or the other pamphlets listed above.

Con- nection index (see page 2)	Number of individual pump cylinders or radials per port		Delivery flow coding (guideline figure Q in (lpm) at 1450 rpm)								
			Piston-Ø (mm)								
			6	7	8	10	12	13	14	15	16
			Operation pressure p_{max} (bar)								
			700	600	550	450	350	300	250	200	160
a	1	Indiv. cylinder	0.3	0.41	0.5	0.8	1.2	1.45	1.7	1.9	2.2
b	2	Number of joined pump cylinders from one radial per port (applies to 1- and 2-radial pumps)	0.6	0.83	1.0	1.6	2.4	2.8	3.3	3.8	4.4
c	3		0.9	1.25	1.5	2.5	3.6	4.3	5.1	5.6	6.5
d	4		1.15	1.65	2.15	3.35	4.8	5.7	6.7	7.7	8.7
e	5		1.4	2.08	2.6	4.2	6.0	7.0	8.3	9.5	10.9
f	6		1.8	2.45	3.2	5.0	7.2	8.6	9.9	11.5	13.1
g	1 x 5	Number of joined radials per port (applies to all multiple- radial pumps)	1.4	2.08	2.6	4.2	6.0	7.0	8.3	9.5	10.9
h	1 x 7		2.1	2.9	3.7	5.8	8.4	9.8	11.8	13.3	15.3
i	2 x 5		2.7	4.15	5.3	8.2	12.0	14.2	16.8	19.3	21.7
k	2 x 7		4.0	5.85	7.4	11.6	17.0	20.0	23.5	26.5	30.4
l	3 x 5		4.6	6.2	8.25	13.0	18.8	22.5	25.2	28.5	32.6
m	3 x 7		5.95	8.75	11.2	17.3	25.5	29.9	35.3	39.8	45.6
n	4 x 7		8.0	11.65	15.0	23.0	34.0	40.0	47.0	53.0	60.8
o	5 x 7		10.6	14.55	18.3	28.8	42.5	50.0	58.4	66.7	76.0

1) The operating pressure should be restricted for applications with continuous operation where the subsequent load cycles are all at the upper end of the pressure range (>75%) e.g. accumulator charging etc.
 It is advisable for an economic service life of the bearings to restrict the operating pressure of the respective pump element diameter to about 75% of its original specification. Another pump with smaller but more pump elements should be selected, if this is not possible.



1800-OILSOL
1800-645765

<https://oilsolutions.com.au/>

sales@oilsolutions.com.au



HAWE HYDRAULIK SE
STREITFELDSTR. 25 • 81673 MÜNCHEN

D 6010 DB
Radial piston pump type R, RG

2. Available versions, main data

The number of pressure ports possible depends on the cover plate size (see D 6010 H). The type over view below illustrates that port 1 stands for port 1 at the pump (see also D 6010 D), port 2 is fed by the remaining cylinders or radials of the pump. Should there be more than two pressure ports, the larger number of remaining cylinders or radials of the pump to be grouped will be connected to port 2.

The R pump to be used should be selected according to table 1 (see also sect. 2.1 in D 6010 D). The individual delivery flow codings to be grouped at one port on the cover plate are shown between slashes. Sect. 2.1 to 2.3 comprise the possible combinations for standard units, depending on the number of pressure ports on the cover plate. The connection index a - o are to be replaced by the respective flow codings (see sect.1) desired to create the final order coding. Joined deliveries led out to one pressure port on the cover plate should normally employ cylinders with identical diameter. It is possible mix cylinders with different diameter to achieve a certain delivery at one port, but their diameter. The max. pressure rating for each port depends on the utilized pump cylinders.

2.1 Design 6010 and 6011

1-radial pump

Order example 1):

Power pack with three pressure ports on the cover plate

R 5,1 / 0,8 - 0,8 / 0,3 - 0,3 / B 20 - V 1,5 3~ 230/400V 50 Hz

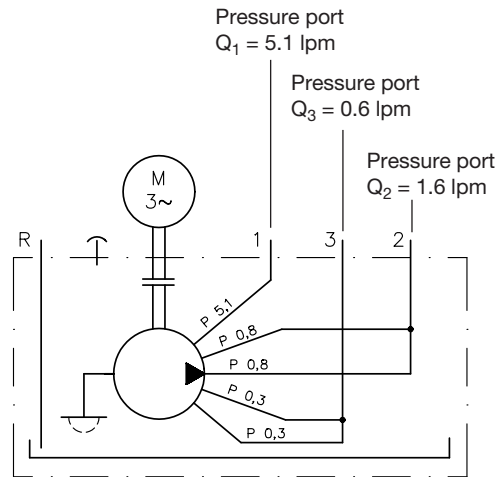
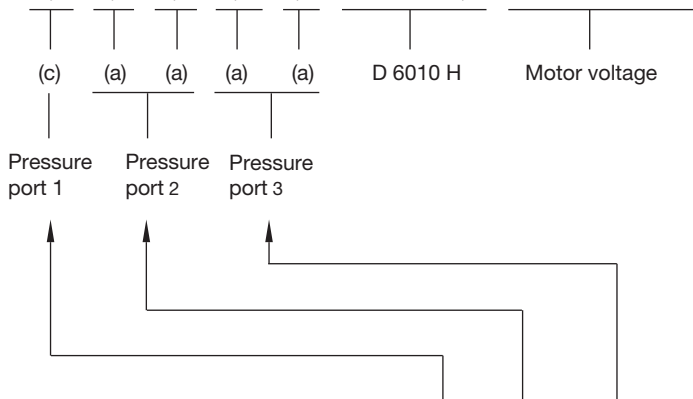

Design and number of cylinders	No. of pressure ports on the cover plate	Grouped delivery (acc. to connection index a to f in sect. 1) at port No. ... on the cover plate							Suited cover plates and tanks acc. to D 6010 H and D 6010 Z
		1	2	3	4	5	6	7	
6010 2-cyl. pump	2	a	a						B 6 and D 6 4) B 13 and D 13.1 4) B 20 and D 13.2 4) B 30, B 40 and D 30 4) B 50 and D 50.1 } max. 4 B 75 and D 50.2 } ports
	3-cyl.-pump	2	b	a					
		3	a	a	a				
6011 5-cyl.-pump	2	d	a						
		c, b 2)	a - a						
	3	c	a	a					
		b	a - a	a					
		4	b, a 3)	a	a	a			
5	a	a	a	a	a				
see above example 7-cyl.-pump	2	f	a						
		e	a - a						
		d, c 2)	a - a - a						
	3	e	a	a					
		d	a - a	a					
		c, b 2)	a - a	a - a					
	4	d	a	a	a				
		c	a - a	a	a				
5	a	a	a	a	a				
6	a 3)	a	a	a	a	a			
7	a	a	a	a	a	a	a		

1) R 5,1/0,8-0,3-0,8-0,3 would be the coding for a pump alone without tank (acc. to D 6010 D)

2) One cylinder of this group is a dummy, see also illustration in sect 2.3 of D 6010 D

3) One cylinder of this 5- (7-) cylinder radial is a dummy

4) Versions with only two pressure ports on the cover plate may also be equipped with connection blocks A... or E... respectively, B... or F... featuring pressure limiting valves (see D 6010 H, sect. 2.3.3).

2.2 Design 6012

2-radial pump

Order example 1):

Power pack (cover plate version) with four pressure ports on the cover plate

R 9,5 - 3,8 / 0,8 / 0,8 / 0,5 / D 20 - V 2,2 3~ 230/400V 50 Hz

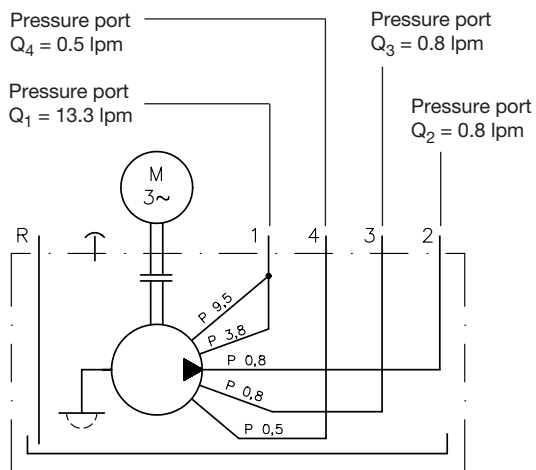
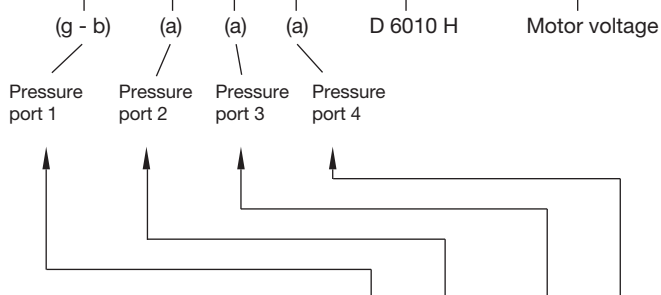

Design and number of cylinders	No. of pressure ports on the cover plate	Grouped delivery (acc. to connection index a to h in sect. 1) at port No. ... on the cover plate								Suited cover plates and tanks acc. to D 6010 H and D 6010 Z	
		1	2	3	4	5	6	7	8		
2 x 5 cylinders	2	g	g								B 20 and D 20 ²⁾ B 30, B 40 and D 40 ²⁾ B 50 and D 50.1 } max. 4 ports B 75 and D 50.2 } B 100 a. D 100.1 } max. 6 ports B 160 a. D 100.2 }
		g - d	a								
		g - c	a - a								
		g - b	a - a - a								
	3	g	d	a							
		g	c	a - a							
		g - c	a	a							
		g - b	a - a	a							
	4	g - a	a - a	a - a							
		g	c	a	a						
		g	b	a - a	a						
	5	g - b	a	a	a						
g - a		a	a	a	a						
g		b	a	a	a						
6012	2	h	h							B 20 and D 20 ²⁾ B 30, B 40 and D 40 ²⁾ B 50 and D 50.1 } max. 4 ports B 75 and D 50.2 } B 100 a. D 100.1 } max. 6 ports B 160 a. D 100.2 }	
		h - f	a								
		h - e	a - a								
		h - d	a - a - a								
	3	h	f	a							
		h	e	a - a							
		h - e	a	a							
		h - d	a - a	a							
	4	h - c	a - a	a - a							
		h	e	a	a						
		h	d	a - a	a						
	5	h	c	a - a	a - a						
h		a - a	a - a	a - a	a						
h - d		a	a	a	a						
h - c		a - a	a - a	a - a	a - a						
6	h	c	a	a	a	a					
	h	a - a	a - a	a	a	a					
	h - a	a - a	a	a	a	a					
7	h	a - a	a	a	a	a	a				
	h - a	a	a	a	a	a	a				
8	h	a	a	a	a	a	a	a			

see above example

1) R 9,5/3,8 -0,8-0,8-0,5 would be the coding for a pump alone without tank (acc. to D 6010 D)
2) Versions with only two pressure ports on the cover plate may also be equipped with connection blocks A... or E... respectively, B... or F... featuring pressure limiting valves (see D 6010 H, sect. 2.3.3).

2.3 Design 6014 to 6016

4- and 6-radial pump

Order example 1):

Power pack with two pressure ports on the cover plate

R 29,9 / 2,1 / B 50 - V 3 3~ 230/400V 50 Hz

(m) (h) D 6010 H Motor voltage
 Pressure port 1 Pressure port 2
 1) R 29,9-2,1 would be the coding for a pump alone without tank (acc. to D 6010 D)

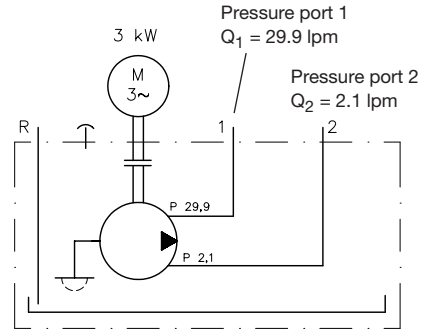

	Design and number of cylinders						6016										
	6014			6016			6014			6016							
	4 x 5 cylinders			4 x 7 cylinders			6 x 7 cylinders			6 x 7 cylinders							
	No. of pressure ports on the cover plate																
	2		3		4		2		3		4		5		6		
1	i	l	i	g	m	k	k	h	o	n	m	n	m	k	m	k	h
2	i	g	g	g	h	k	h	h	h	k	m	h	h	k	h	k	h
3			g	g			h	h			h	h	k	h	h	h	h
4				g				h					h	h	h	h	
5																h	h
6																h	
Suited cover plates and tanks acc. to D 6010 H and D 6010 Z	B 50 and D 50.1 B 75 and D 50.2 B 100 and D 100.1 B 160 and D 100.2			B 250 and D 250.1 B 400 and D 250.2			B 100 and D 100.1 B 160 and D 100.2 B 250 and D 250.1 B 400 and D 250.2										

2.4 Pressure limitation with power packs B(D) 6 to B(D) 40

The tank and cover plate versions with only two pressure ports on the cover plate may also be equipped with connection blocks featuring pressure limiting valves (A... or E... tool adjustable and B... or F... manually adjustable), for details see D 6010 H, sect. 2.3.3. The codings for these connection blocks should be added subsequently, in the same order as the pressure ports, directly after the tank (cover plate) specification.

When only one connection block is desired the other one has to be negated with a „X“ (see example below).

A direct installation of pressure-limiting valves is not possible on tank sizes B 50 - B 400 (cover plates D 50.1 -D 250.2) due to limited space.

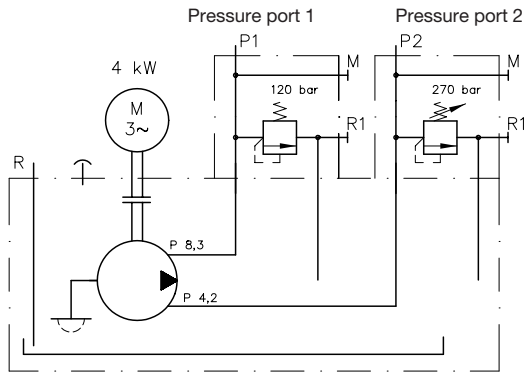

Pressure ports 1 and 2 safeguarded on the power pack

R 8,3/4,2/B20 -V4 - A/120 - B/270

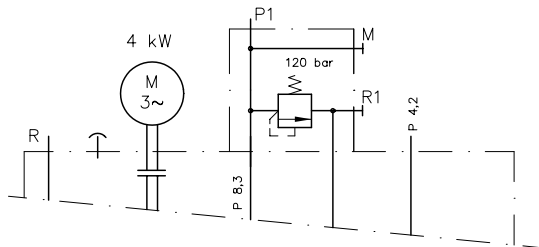

Pressure port 1 safeguarded on the power pack

R 8,3/4,2/B20 -V4 - A/120 - X

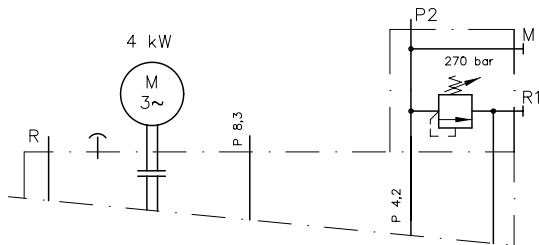

Pressure port 2 safeguarded on the power pack

R 8,3/4,2/B20 -V4 - X - B/270

2.5 Directional valve banks

Various directional seated and directional spool valve banks can be directly mounted at the connection blocks with pressure limiting valve suited for B(D) 6 to B(D) 40 acc. to sect. 2.4. However the number of sections at these valve banks is limited due to spatial reasons. It has to be specified in uncoded text, when both pressure ports are equipped with connection blocks featuring pressure limiting valves but only one should show a directly mounted valve bank.

It is recommended to equip these valve banks with idle circulation valves, that they can be arbitrarily activated whenever one of the deliveries is not needed for prolonged periods.

Directional valve bank		Number of valve sections within the valve bank				The directional seated and directional spool valve mounted at pressure port 2 sticks will protrude the outline of the cover plate. This means usually the risk of damage and it is therefore recommended that no more than two section are installed there. In general it is better to install this valve bank more remote, connecting it via pipes. The same applies to directional spool valve banks type SW (D 7450 and D 7451), which anyway cannot be directly mounted. For possible ways of connection, see the respective pamphlets.
		Pressure port P 1			Pressure port P 2	
		D 6	D 13 D 20	D 30 D 40	D 6 ... D 40	
D 7302 1) 2)	VB 01C	2	3	5		
	VB 11C	2	3	4		
	VB 21C	1	2	3		
D 7470 B/1 1) 2)	BWN(H) 1C	2	3	5		
	BWH 2C	2	3	4		
	BWH 3C	1 3)	2	4		
D 7230-1	SKP 06(16)	2	3	4		
	SKH 06(16)	1	2	4		

1) Double valves coding J and G (D 7032) or J and L (D 7470 B/1) are counted like two valve sections (partly not suited for cover plate D 6).

2) Valve sections (D 7302 and D 7470 B/1) featuring pressure switches at their under side cannot be directly mounted.

3) Over-dimensioned for the pump deliveries available with D(B) 6.

Order example: **R 2,5 / 1,45 -1,45 / B13 - V3 - A/400 - BWH1C - FN-1-1-G 24**
- A/120 - BWH1C - FT-1-1-G 24 Motor voltage 3~ 230/400V 50 Hz

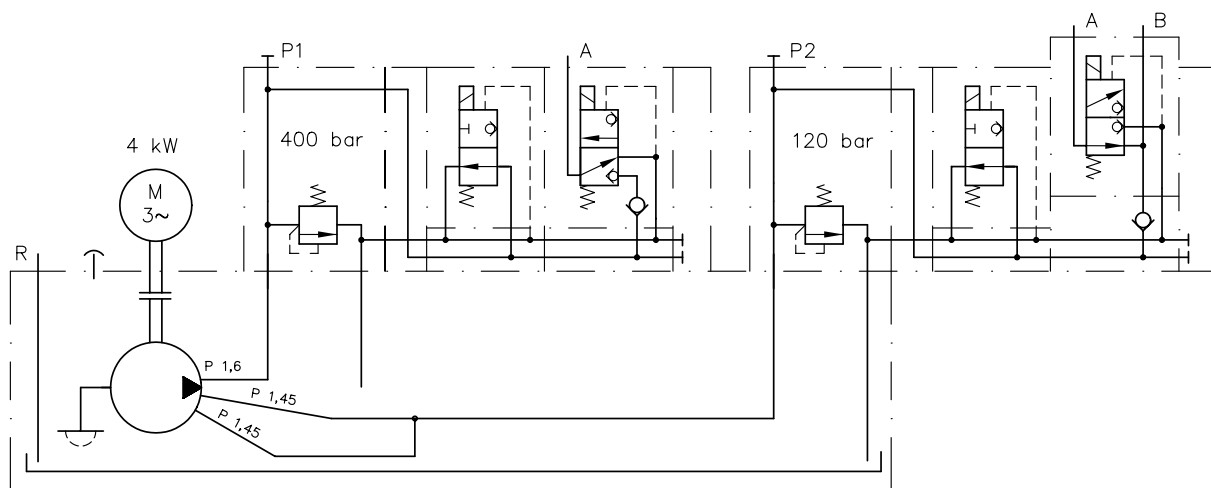

2.6 Dual stage port Z

$P_{max LP} = 120 \text{ bar}$

$Q_{max} = 18 \text{ lpm}$

Circulation back pressure approx. 6 bar at 12 lpm.

There are dual stage valves available for tanks B 6 to 40 and cover plates D 6 to 40. This valve enables that two pump deliveries to be fed at one port on the cover plate, with one delivery being automatically switched into idle circulation as soon as a set pressure is achieved and exceeded. This idle circulation mode is maintained by the circuit continuing to deliver.

Order example:

Pressure circuit 1: 9.5 lpm switched into idle circulation at 70 bar

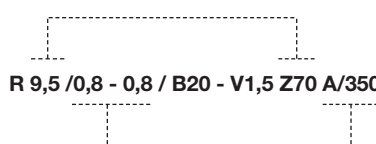

R 9,5 / 0,8 - 0,8 / B20 - V1,5 Z70 A/350 Motor voltage 3~ 230/400V 50 Hz

Pressure circuit 2: 1.6 lpm (2 x 0.8 lpm internally connected) is safeguarded at 350 bar

(Version without pressure limiting valve):

R 9,5 / 0,8 - 0,8 / B20 - V1,5 Z70 X Motor voltage 3~ 230/400V 50 Hz

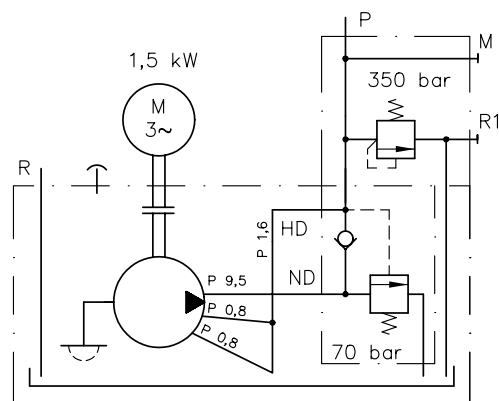

3. Unit dimensions All dimensions in mm, subject to change without notice!

3.1 Power packs D 6 to D 40 and B 6 to B 40 Tank zinc plated, cover plate made out of light alloy

Version with two pressure ports

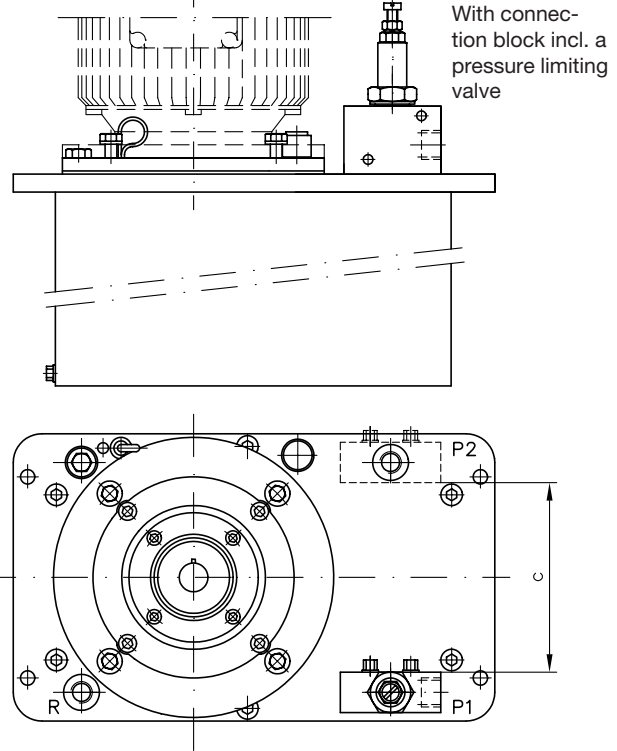
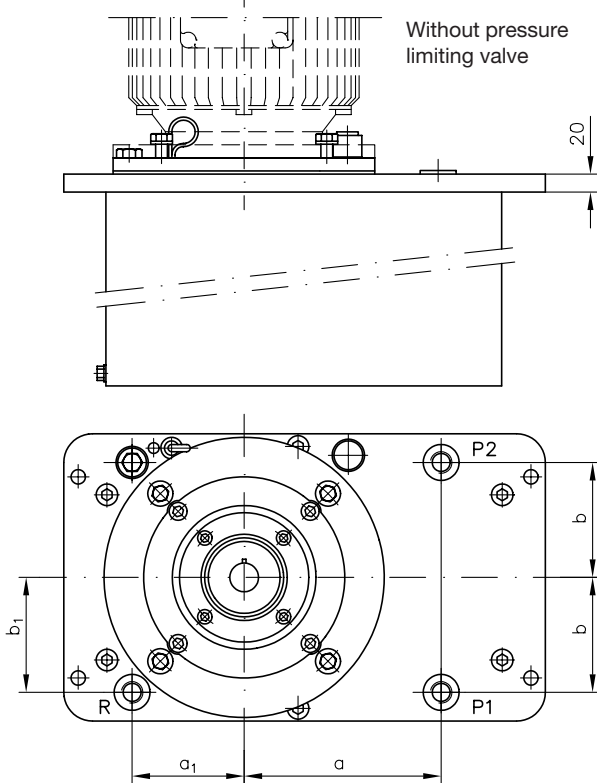

Type	a	a ₁	b	b ₁	c
D 6, B 6	126	85	84	86	133
D(B) 13, D(B) 20	175	103	108	105	181
D(B) 30, D(B) 40	175	75	133	130	213

The length of valve banks at P1 is restricted because of P2.

Ports conf. ISO 228/1 (BSPP):
Pressure ports P1 and P2 = G 1/2

For missing dimensions, see D 6010 H

Version with more than two pressure ports

Type D 6 and B 6

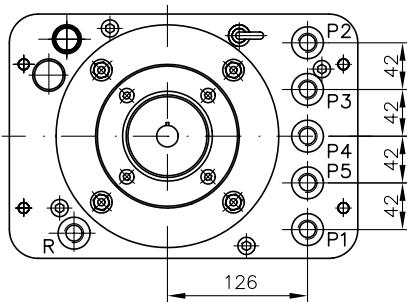

Type D 13.. and D 20 as well as B 13 and B 20

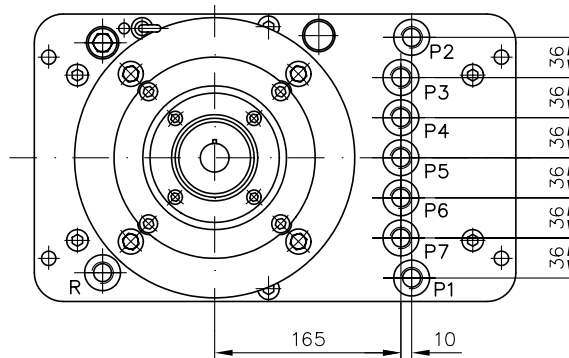

Type D 30 and D 40 as well as B 30 and B 40

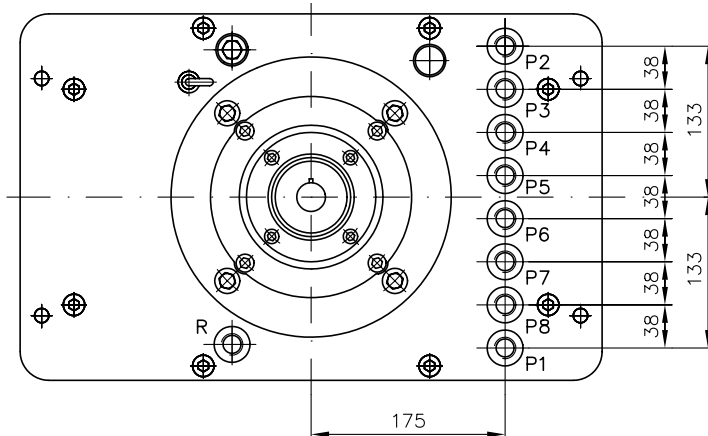

Ports conf. ISO 228/1 (BSPP):
Pressure ports P1 to P8 = G 1/2

Cover plate strength (20 mm) and location of port R (a₁ and b₁) as above. For all other dimensions, see D 6010 H.

Important note:

All unused pressure ports must be blocked with a disc plug (DIN 470)!

3.2 Power packs D 50.. to D 250.. and B 100 to B 400

Grey primer is applied to tank and cover plate

Type D 50.. as well as B 50 and B 75

For missing dimensions, see D 6010 H!

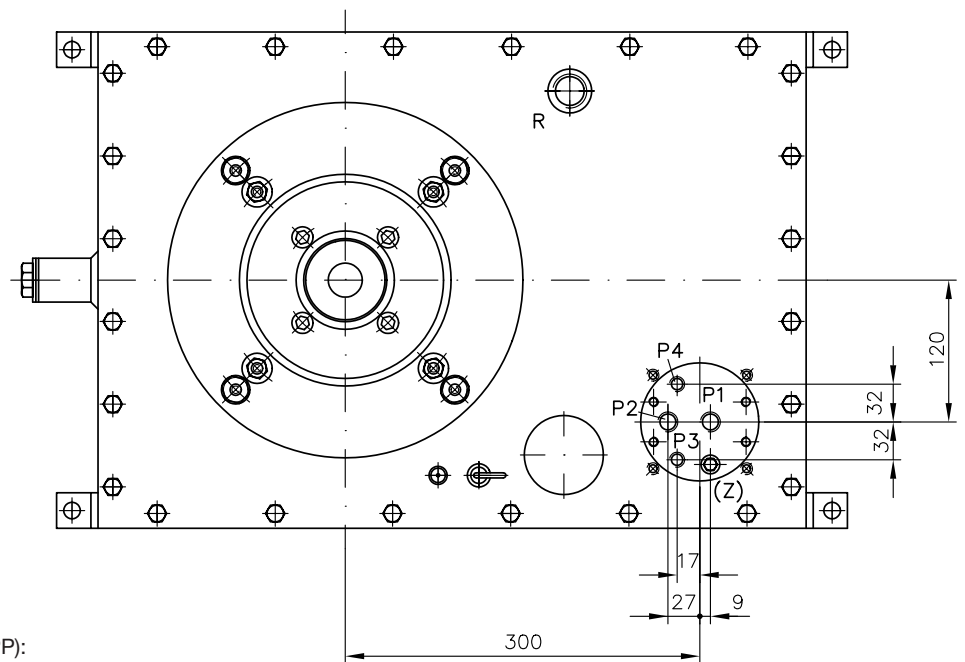
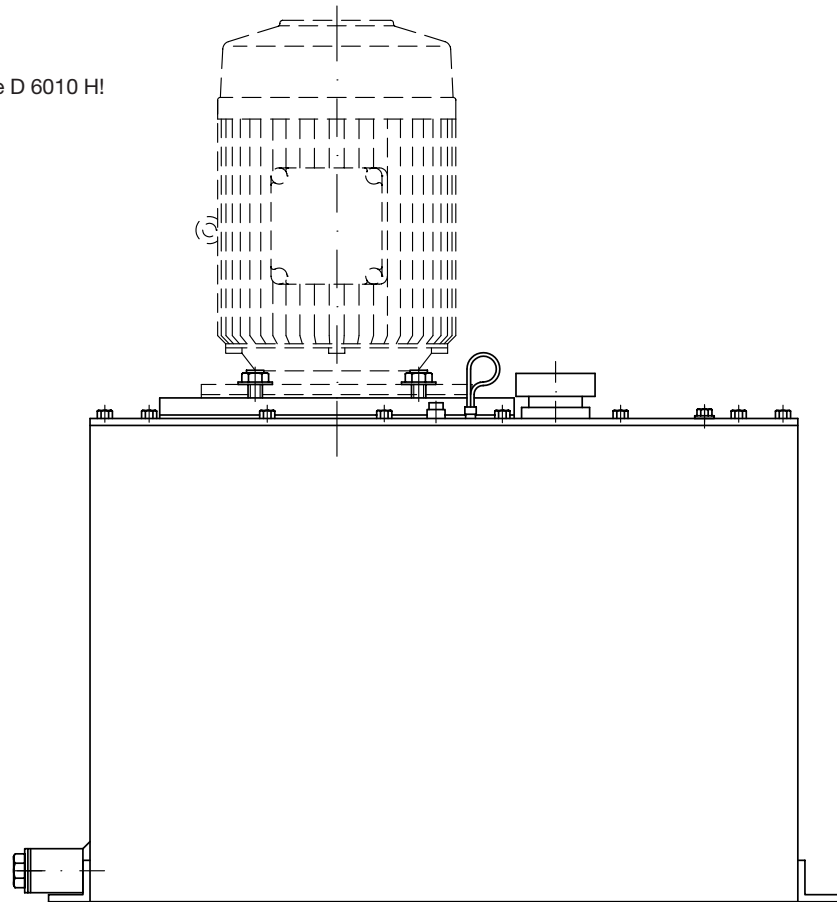

Ports conf. ISO 228/1 (BSPP):
 Pressure ports P1 and P2 = G 1/2
 Pressure ports P3 and P4 = G 3/8
 Return port R = G 1

Important note:

All unused pressure ports must be blocked with a tapped plug (DIN 910)!

Power packs D 100.. to D 250.. and B 50 to B 400
 Grey primer is applied to tank and cover plate

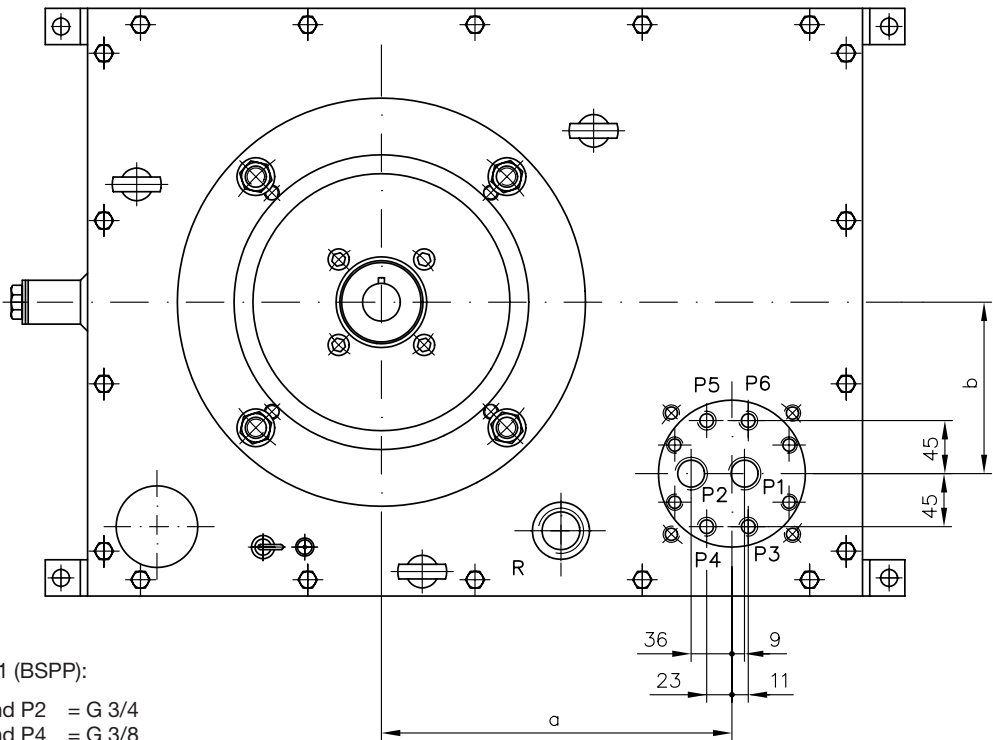
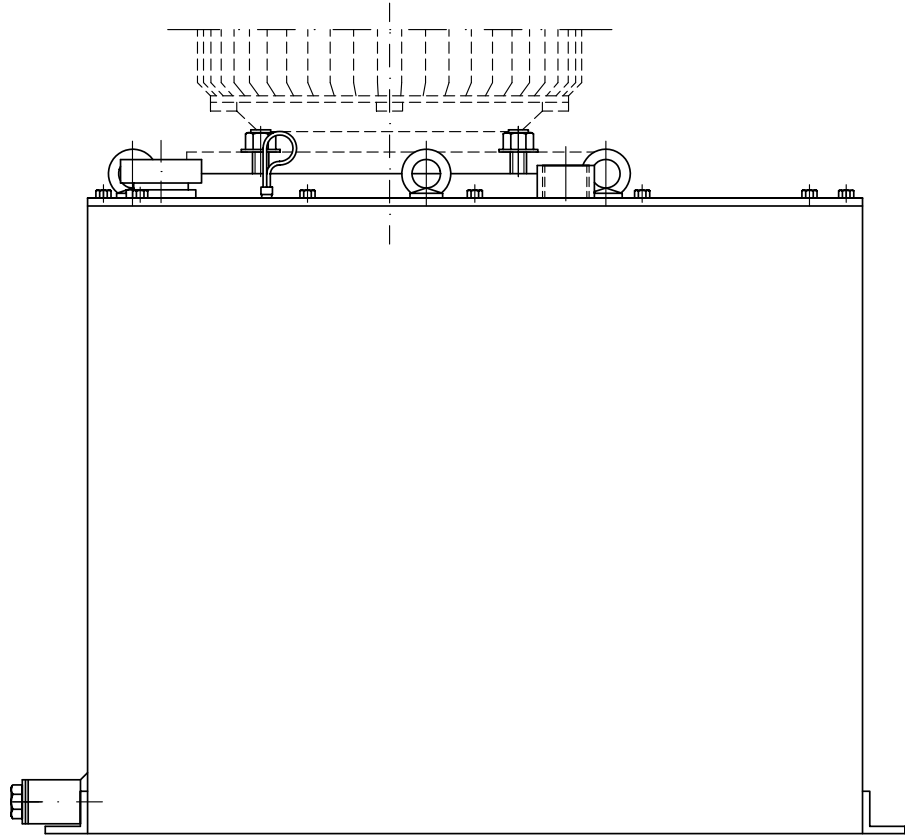

Ports conf. ISO 228/1 (BSPP):

- Pressure ports P1 and P2 = G 3/4
- Pressure ports P3 and P4 = G 3/8
- Return port R = G 1 1/4

For missing dimensions, see D 6010 HI!

Important note:

All unused pressure ports must be blocked with a tapped plug (DIN 910)!

	D 100.. B 100 and B 160	D 250.. B 250 and B 400
a	295	465
b	145	165

