



ADT912A

Low Pressure Test Pump User's Manual

[Version number:1801V15]

Please download the latest version from www.additel.com



Warnings and cautions

- > Low pressure gauges can very easily be over pressured if not careful. Please take caution when applying pressures.
- > Do not exceed the safety pressure limit 90 psi (6 bar).
- > Do not switch between pressure and vacuum mode under pressure.
- > Over tightening connectors may cause damage.
- > Store the pump in the dry and non-corrosive environments.
- > All moisture and contaminants should be cleaned out of the liquid isolator before creating a vacuum. This is accomplished by venting the pump when at high pressure.
- > For the least risk in contamination of the reference gauge, the DUT should be installed to the pressure port which is closest to the vent valve.
- > Additel is not liable for any safety problems or damages caused by misuse or incorrect operation.

Specification

- > **Pressure range:** 95% vacuum to 60 psi (4 bar)
- > **Temperature:** 0~50 °C
- > **Humidity:** < 95%RH
- > **Pressure Resolution:** 0.1 Pa (0.001 mbar)
- > **Safety pressure:** < 90 psi (6 bar)
- > **Pressure media:** Air
- > **Size:** Height: 5.51" (140 mm);
Base: 10.75" (273 mm) x 10.16" (258 mm)
- > **Weight:** 6.2 lb (2.8 kg)

Configuration & Air routine

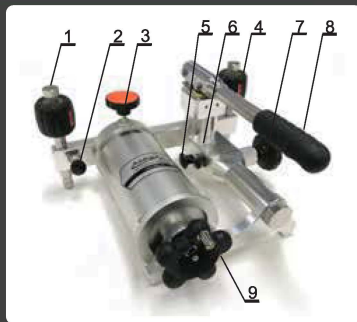

- 1 – Quick connector
- 2 – Vent valve
(clockwise to close/ counterclockwise to open)
- 3 – Fine adjust handle
(clockwise to increase pressure)
- 4 – Quick connector
- 5 – Pressure/vacuum (P/V) selector
(Positive pressure: pull it out; Vacuum: push it in)
- 6 – Safety bolt pin
(use it to ensure safety)
- 7 – Isolation valve
(isolates the calibration volumn from pressurizing system)
- 8 – Hand pump
- 9 – Main adjust handle
(clockwise to increase pressure)

Air routine

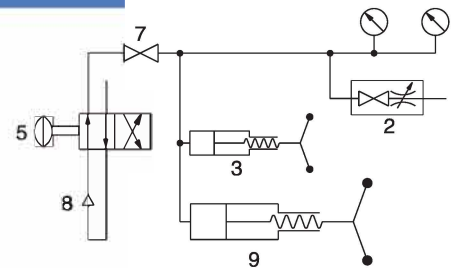

Troubleshooting

Problem	Cause	Solution
Hand pump will not generate pressure	The isolation valve is not open.	Open the isolation valve.
It is difficult to increase pressure	A. Release valve is not closed.	Close the release valve.
	B. The O-ring seal is loose or damaged.	Replace the O-ring seal.
	C. P/V selector is in the wrong position.	Pressure: pull the P/V selector out; Vacuum: push the P/V selector in.
Hard to use fine adjustment handle	A. The isolation valve is not closed.	Close the isolation valve.
	B. The gauges are not tightened.	Tighten the reference gauge or the gauge under test.
	C. The O-ring seal is damaged.	Replace the O-ring seal.
	D. The thread surface is not smooth.	Use Teflon tape on the thread and turn it in tight.
	E. The connector type is mismatched to the gauge pressure port.	Use the correct adapter.
	F. Dust or contaminants are blocking the pressure flow.	Repeat pressurizing the pump several times and then suddenly vent it which will push any contaminants out.
It is difficult to turn the quick connector	A. Too much force was previously applied.	Secure the quick connection with less force.
	B. The threads have no lubrication.	Apply lubrication to the threads.

O-Rings for pressure connector

P/N	Size	Connector
1611300004	4X1.5	M10X1, 1/8BSP, 1/8NPT
1611300220	6.5X3	M20X1.5, 1/2BSP, 1/2NPT
1611300024	6X2	M14X1.5, 1/4BSP, 1/4NPT, 3/8BSP



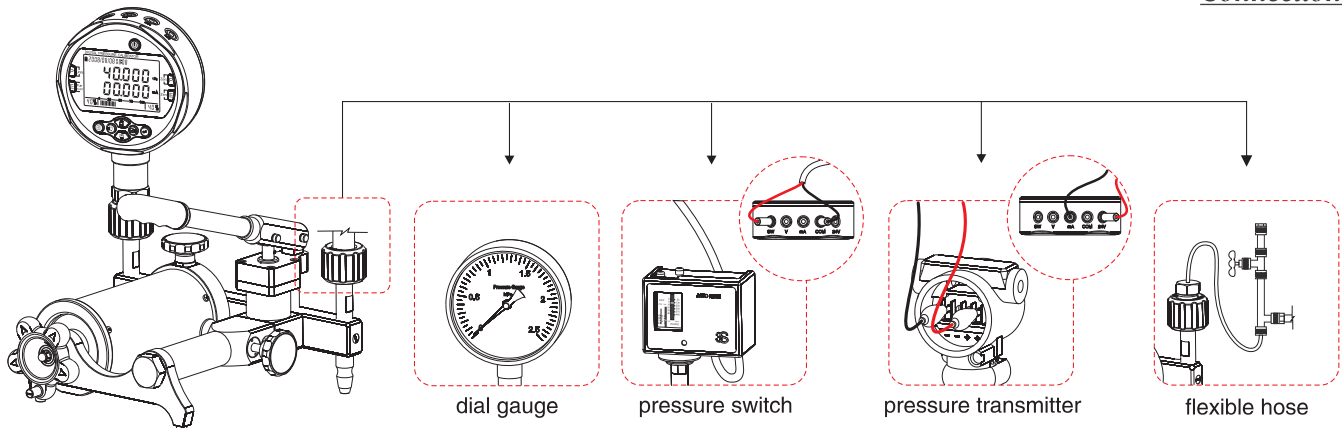

B Vent

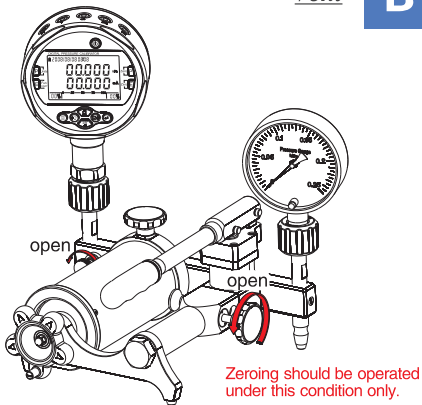

C Pre-pressure

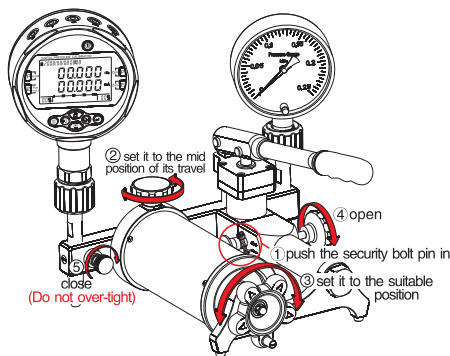

D Increasing pressure

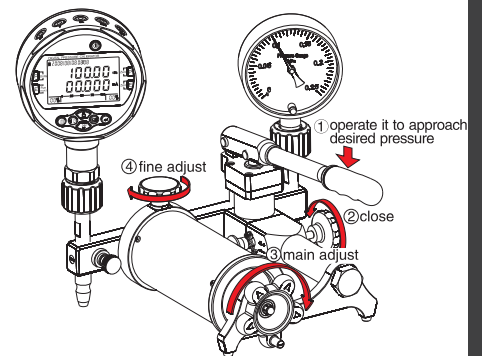

E Repeat pressurizing

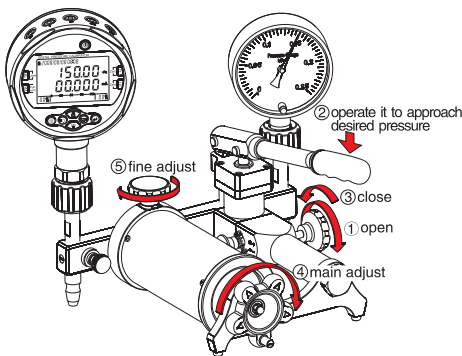

F Decreasing pressure

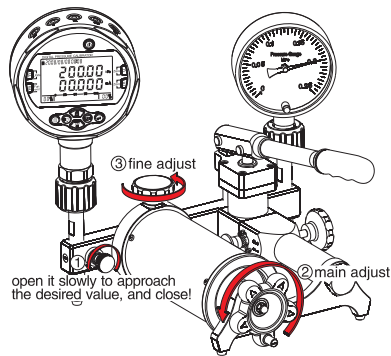

G Vacuum preparation

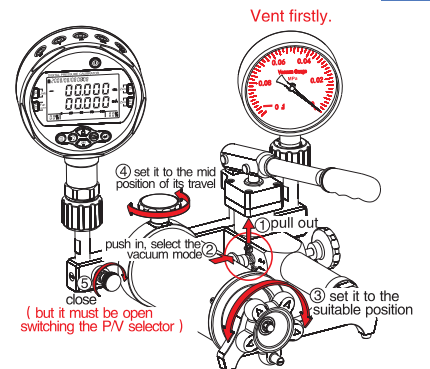

H Increasing vacuum pressure

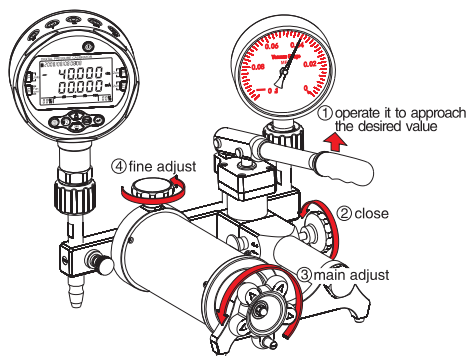

I Repeat vacuum pressure

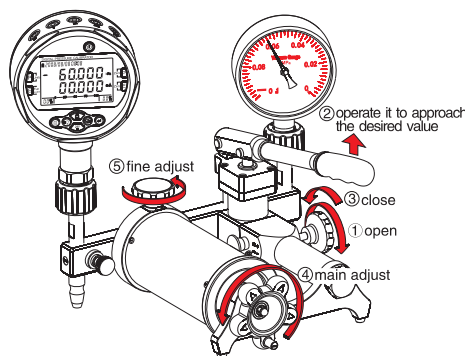

J Decreasing vacuum pressures

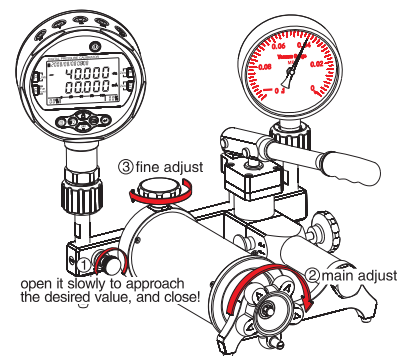

Remark: A: Additel has made a concerted effort to provide complete and current information for the proper use of the equipment. The product specifications and other information contained this manual are subject to change without notice.
B: Above pictures are just for reference.