

Warnings and cautions

- Low pressure gauges can very easily be over pressured if not careful. Please take caution when applying pressures.
- Do not exceed the safety pressure limit of 1000 psi (70bar).
- Do not switch between pressure and vacuum mode under pressure.
- Over tightening connectors may cause damage.
- Store the pump in dry and non-corrosive environments.
- All moisture and contaminants should be cleaned out of the liquid isolator before creating a vacuum. This is accomplished by venting the pump when at high pressure.
- For the least risk in contamination of the reference gauge, the DUT should be installed to the pressure port which is closest to the vent valve.
- Additel is not liable for any safety problems or damages caused by misuse or incorrect operation.

Specification

- **Pressure range:** 95% vacuum to 375 psi (25 bar)
- **Temperature:** 0-50 °C
- **Humidity:** < 85%RH
- **Adjusting fineness:** 10 Pa (0.1 mbar)
- **Safety pressure:** < 1000 psi (70 bar)
- **Pressure media:** Air
- **Size:** Height: 5.12" (130 mm);
Base: 9.45" (240 mm) x 4.72" (120 mm)
- **Weight:** 3.3 lb (1.5 kg)



ADT914A

Handheld Pneumatic Pressure Test Pump User's Manual

[Version number:1601V13]

Please download the latest version from www.additel.com



Configuration & Air routine

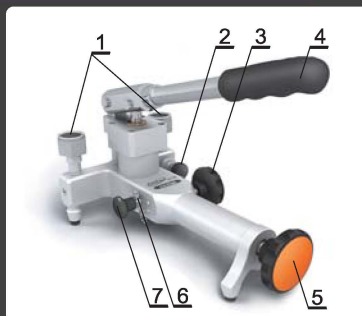

- 1 – **Quick connector**
- 2 – **Vent valve**
(clockwise to close/ counterclockwise to open)
- 3 – **Isolation valve**
(isolates the calibration volumn from pressurizing system)
- 4 – **Hand pump**
- 5 – **Fine adjust handle**
(clockwise to increase pressure)
- 6 – **Security bolt pin**
(use it to ensure safety)
- 7 – **Pressure/vacuum (P/V) selector**
(Postive pressure: pull it out; Vacuum: push it in)

Air routine

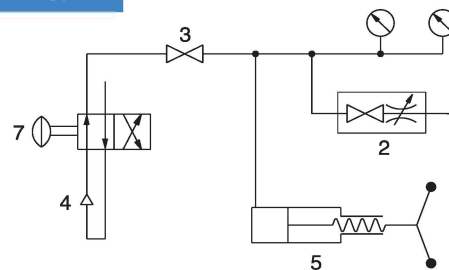

Troubleshooting

Problem	Cause	Solution
Hand pump will not generate pressure	The isolation valve is not open.	Open the isolation valve.
It is difficult to increase pressure	A. Vent valve is not closed.	Close the vent valve.
	B. The O-ring seal is loose or damaged.	Replace the O-ring seal.
	C. P/V selector is in the wrong position.	Pressure: pull the P/V selector out; Vacuum: push the P/V selector in.
Hard to use the fine adjust	A. The isolation valve is not closed.	Close the isolation valve.
	B. The gauges are not tightened.	Tighten the reference gauge or the gauge under test.
	C. The O-ring seal is damaged.	Replace the O-ring seal.
	D. The thread surface is not smooth.	Use Teflon tape on the thread and turn it in tight.
	E. The connector is mismatched to the gauge pressure port.	Use the correct adapter.
	F. Dust or contaminants are blocking the pressure flow	Repeat pressurizing the pump several times and then suddenly vent which will push any contaminants out.
It is difficult to turn the quick connectors	A. Too much force was previously applied.	Secure the quick connection with less force.
	B. The threads have no lubrication.	Apply lubrication to the threads.

O-Rings for pressure connector

P/N	Size	Connector
161130004	4X1.5	M10X1, 1/8BSP, 1/8NPT
1611300220	6.5X3	M20X1.5, 1/2BSP, 1/2NPT
1611300024	6X2	M14X1.5, 1/4BSP, 1/4NPT, 3/8BSP



1800-OILSOL
1800-645765

<https://oilsolutions.com.au/>

sales@oilsolutions.com.au

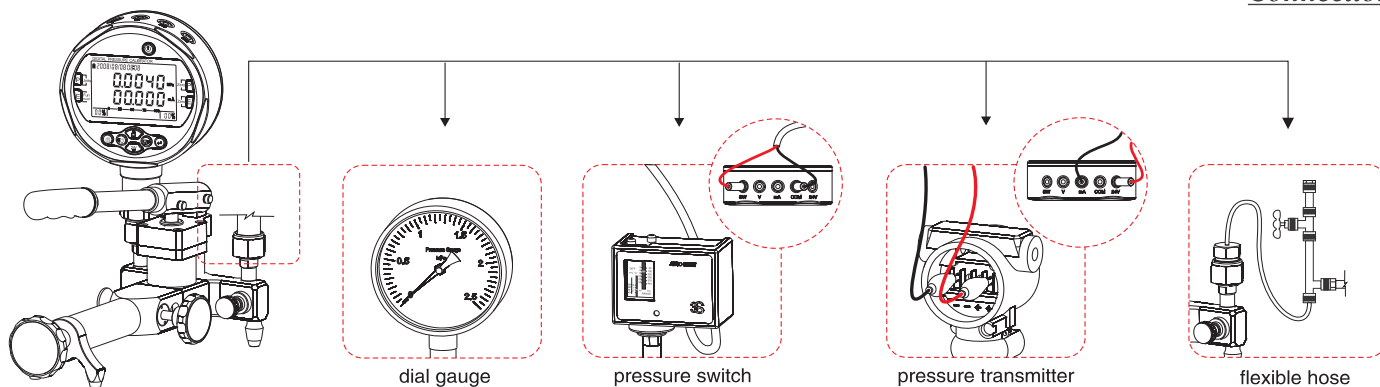

B *Vent*

Zeroing should be operated under this condition only.

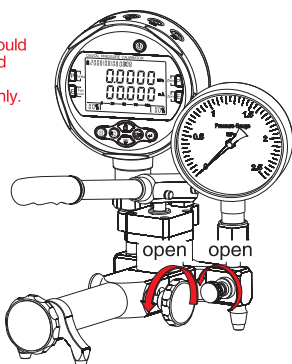

C *Pre-pressure*

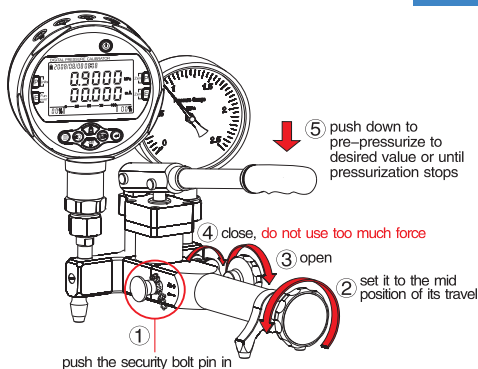

D *Increasing pressure and fine adjustment*

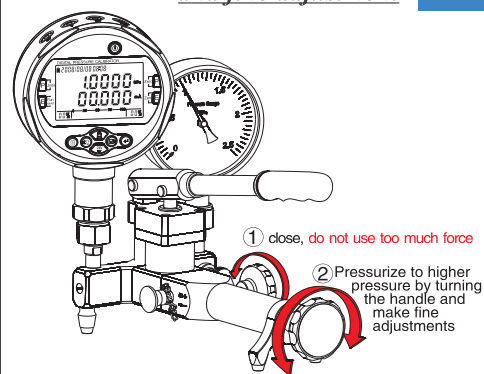

E *Decreasing pressure*

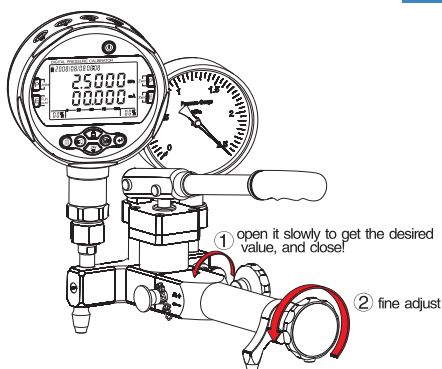

F *Vacuum pressures*

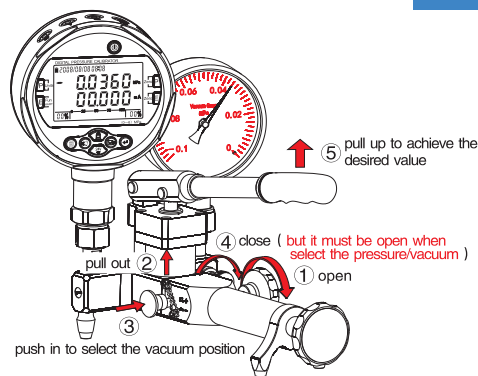

G *Repeat Vacuum pressure*

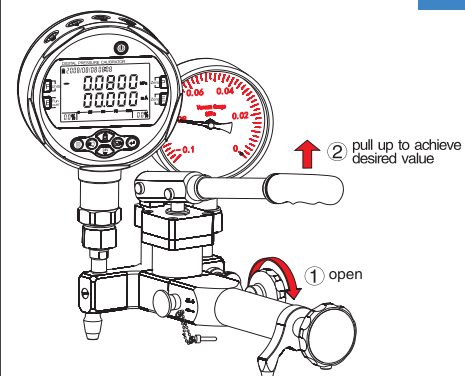

H *Decreasing vacuum pressures*

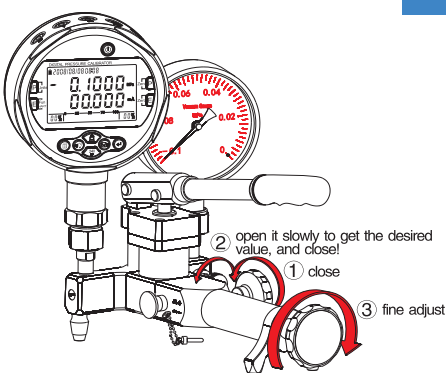

Remark:

A: Additel has made a concerted effort to provide complete and current information for the proper use of the equipment. The product specifications and other information contained this manual are subject to change without notice.

B: Above pictures are just for reference.