



The Professional Choice



OIL SOLUTIONS

LHC

With hydraulic motor

PO Box 38
Strathfieldsaye, VIC, 3551
1800 OIL SOL
1800 645 765

sales@oilsolutions.com.au

www.oilsolutions.com.au

"For All Your Hydraulic Needs"



OLAER LHC | optimized for mobile and industrial use



Olaer is a global player specialising in innovative, efficient system solutions for temperature optimisation and energy storage.

All over the world, our products are working in the most diverse environments and applications.

LHC Air Oil Coolers

For mobile and industrial use - maximum cooling capacity 160 kW

The LHC air oil cooler with hydraulic motor is optimized for use in the mobile and industrial sector. Together with a wide range of accessories, the LHC cooler is suitable for installation in most applications and environments. The maximum cooling capacity is 160 kW at ETD 40 °C. Choosing the right cooler requires precise sizing. The most reliable way to size is with the aid of our calculation program. This program, together with precise evaluations from our experienced, skilled engineers, gives you the opportunity for more cooling per € invested.



Overheating - an expensive problem

An under-sized cooling capacity produces a temperature balance that is too high. The consequences are poor lubricating properties, internal leakage, a higher risk of cavitation, damaged components, etc. Overheating leads to a significant drop in cost-efficiency and environmental consideration.

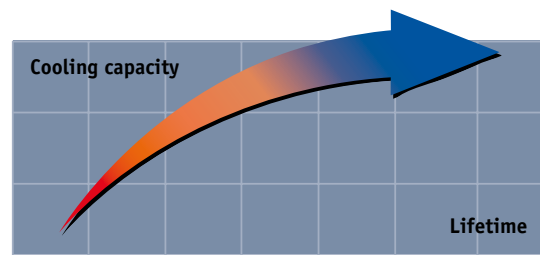

Temperature optimisation - a basic prerequisite for cost-efficient operation

Temperature balance in a hydraulic system occurs when the cooler can cool down the energy input that the system does not consume - the system's lost energy ($P_{loss} = P_{cool} = P_{in} - P_{used}$).

Temperature optimisation means that temperature balance occurs at the system's ideal working temperature - the temperature at which the oil's viscosity and the air content comply with recommended values. The correct working temperature produces a number of economic and environmental benefits:

- The hydraulic system's useful life is extended.
- The oil's useful life is extended.
- The hydraulic system's availability increases - more operating time and fewer shutdowns.
- Service and repair costs are reduced.
- High efficiency level maintained in continuous operation - the system's efficiency falls if the temperature exceeds the ideal working temperature.

Clever design and the right choice of materials and components produce a long useful life, high availability and low service and maintenance costs.

Compact design and low weight.

Easy to maintain and easy to retrofit in many applications.



Hydraulic motor with displacement from 8.4 cm³/r to 25.2 cm³/r.

Collar bearing for fan motor on larger models provides longer useful life.

Quiet fan and fan motor.

Cooler matrix with low pressure drop and high cooling capacity.

LHC-M and LHC-X

LHC air oil coolers are also available in two special versions, LHC-X (ATEX version), approved for applications where there may be an explosive environment above ground, and LHC-M, adapted to be able better to deal with corrosion attacks, for example in marine environments.

Calculate the cooling capacity requirement

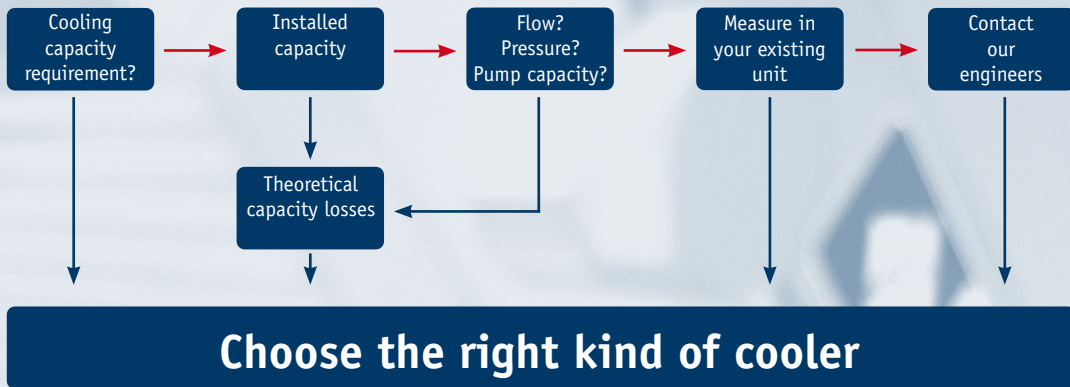

Enter your values

This block contains a collage of images related to the software's output. On the left, there are two screenshots of the software's input and output screens. In the center, there is a technical drawing of the LAC2 011-4-D cooler, showing side and front views with dimensions. Below the drawing is a small photograph of the physical cooler unit. The technical drawing includes the OLAER logo and the model number 'LAC2 011-4-D'. The bottom right corner of the drawing shows a small table with technical specifications.

... suggested solution



Better energy consumption means not only less environmental impact, but also reduces operating costs, i.e. more cooling per € invested.

More cooling per €

with precise calculations and our engineers' support

Optimal sizing produces efficient cooling. Correct sizing requires knowledge and experience. Our calculation program, combined with our engineers' support, gives you access to this very knowledge and experience. The result is more cooling per € invested.

The user-friendly calculation program can be downloaded from www.olaer.se

Valuable system review into the bargain

A more wide-ranging review of the hydraulic system is often a natural element of cooling calculations. Other potential system improvements can then be discussed – e.g. filtering, offline or online cooling, etc. Contact us for further guidance and information.

OLAER's quality and performance guarantee insurance for your operations and systems

A constant striving towards more cost-efficient and environment friendly hydraulic systems requires continuous development. Areas where we are continuously seeking to improve performance include cooling capacity, noise level, pressure drop and fatigue.

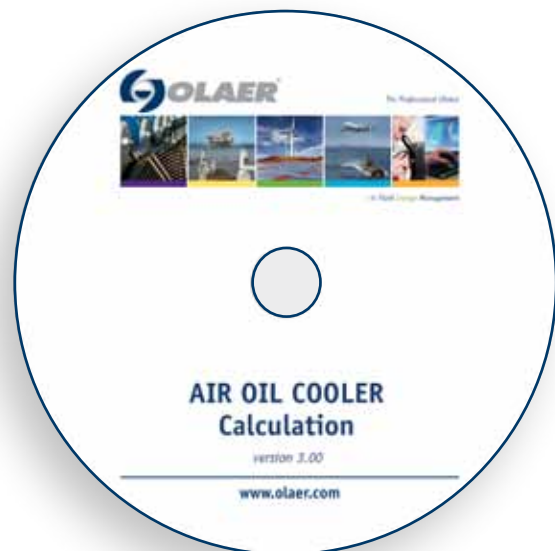

Meticulous quality and performance tests are conducted in our laboratory. All tests and measurements take place in accordance with standardised methods - cooling capacity in accordance with EN1048, noise level ISO 3743, pressure drop EN 1048 and fatigue ISO 10771-1.

For more information about our standardised tests, ask for "OLAER's blue book – a manual for more reliable cooler purchasing".

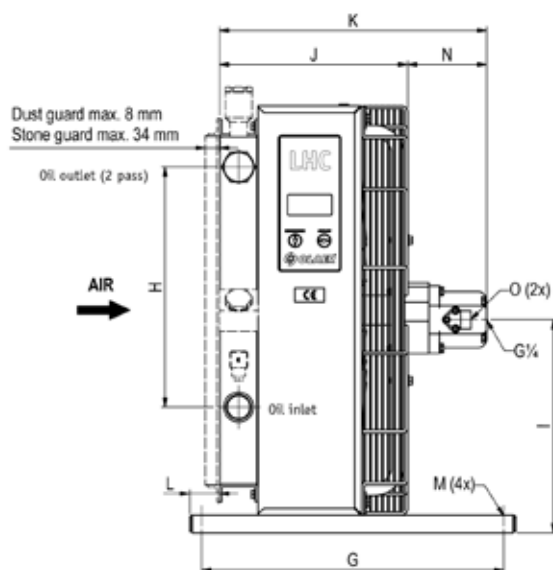

TYPE	Fan speed rpm	Fan capacity kW	Weight kg (approx)	Max speed rpm	Acoustic pressure level LpA dB(A) 1m*
LHC2 007	1500	0.10	10	3500	62
	3000	0.65	10	3500	79
LHC2 011	1500	0.20	15	3500	67
	3000	1.50	15	3500	82
LHC2 016	1000	0.10	18	3500	60
	1500	0.35	18	3500	70
	3000	2.50	18	3500	86
LHC2 023	1000	0.15	30	2840	64
	1500	0.50	30	2840	76
LHC 033	1000	0.65	40	2350	75
	1500	2.00	40	2350	85
LHC 044	1000	0.70	56	2350	77
	1500	2.00	56	2350	86
LHC 056	750	0.75	70	1850	74
	1000	1.80	70	1850	82
LHC 058	750	0.75	77	1850	75
	1000	1.80	77	1850	83
LHC 076	750	0.70	105	1690	80
	1000	1.60	105	1690	87
LHC 078	750	0.70	111	1690	81
	1000	1.60	111	1690	88
LHC 110	750	1.70	117	1440	85
	1000	4.00	117	1440	91
LHC 112	750	1.70	125	1440	86
	1000	4.00	125	1440	92
LHC 113	750	1.70	184	1440	87
	1000	4.00	184	1440	93

* = Noise level tolerance ± 3 dB(A).

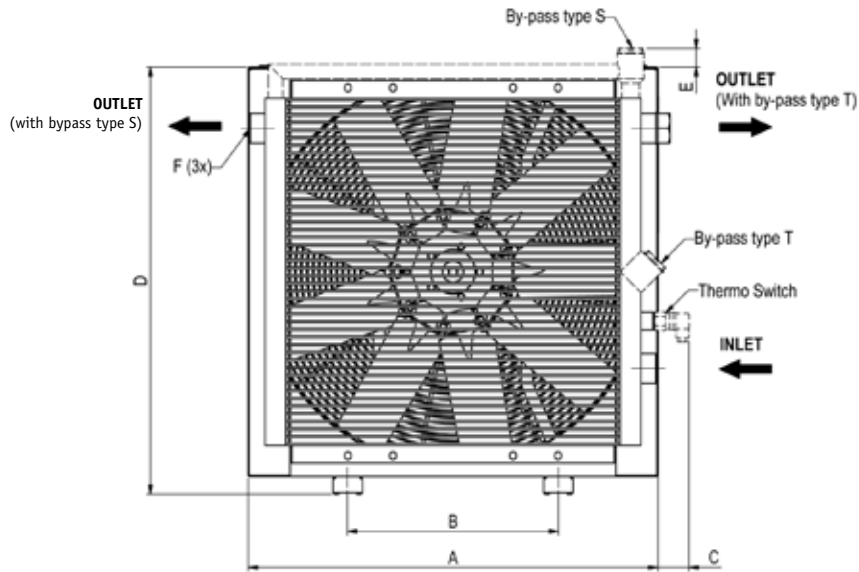

TYPE	A	B	C	D	E	F	G	H	I	J	K	L	MØ
LHC2 007	365	203	64	395	42	G1	510	160	197	225	J+N	50	99
LHC2 011	440	203	62	470	41	G1	510	230	234	249	J+N	50	9
LHC2 016	496	203	66	526	46	G1	510	230	262	272	J+N	50	9
LHC2 023	580	356	44	610	44	G1	510	305	304	287	J+N	50	9
LHC 033	692	356	42	722	42	G1½	510	406	360	318	J+N	50	9
LHC 044	692	356	59	866	59	G1½	510	584	432	343	J+N	50	9
LHC 056	868	508	49	900	43	G1½	510	584	448	368	J+N	50	9
LHC 058	868	508	49	898	43	G2	510	584	448	388	J+N	30	9
LHC 076	1022	518	41	1052	45	G1½	610	821	525	393	J+N	70	14
LHC 078	1022	518	41	1052	45	G2	610	821	525	413	J+N	50	14
LHC 110	1185	600	54	1215	45	G2	610	985	607	418	J+N	70	14
LHC 112	1185	600	54	1215	45	G2	610	985	607	438	J+N	50	14
LHC 113	1200	600	82	1215	45	G2	610	985	607	485	J+N	132	14

MOTOR	Displacement cm ³ /r	N LHC2 007 -LHC2 023	N LHC 033 - LHC 112	O Angular connection	Max. working pressure bar
A	8.4	91	133	G½	210
B	10.8	98	138	G½	210
C	14.4	101	144	G½	210
D	16.8	105	148	G¾	210
E	19.2	110	151	G¾	210
F	25.2	120	165	G¾	160



The cooling capacity curves are based on the inlet oil temperature and the ambient air temperature. An oil temperature of 60 °C and an air temperature of 20 °C produce a temperature difference of 40 °C. Multiply by kW/°C for total cooling capacity.

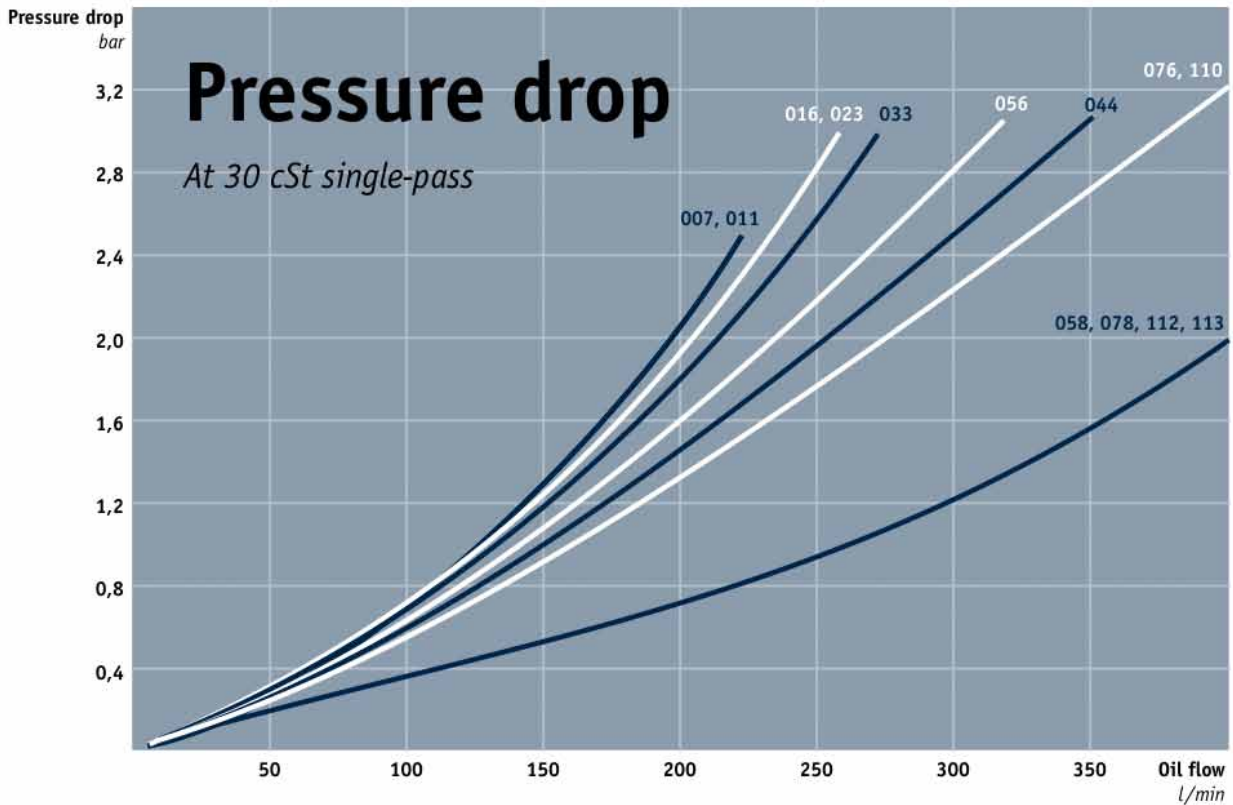

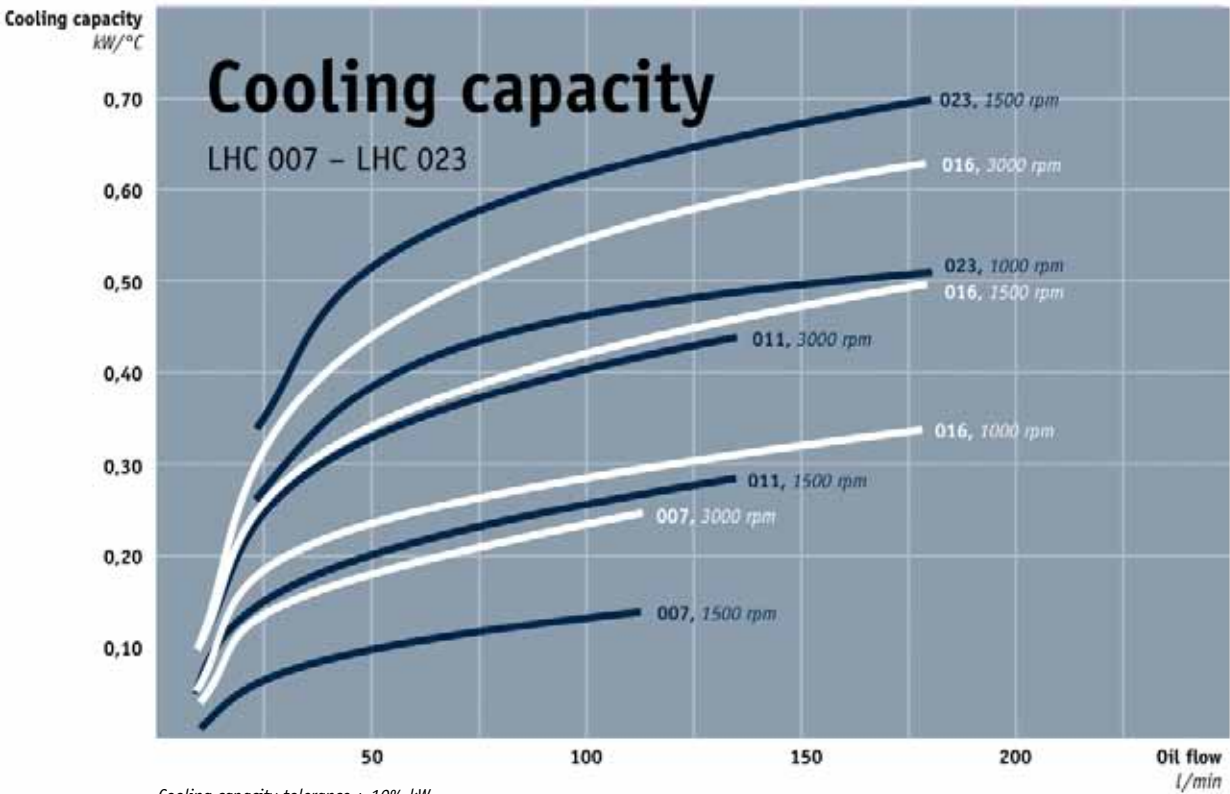
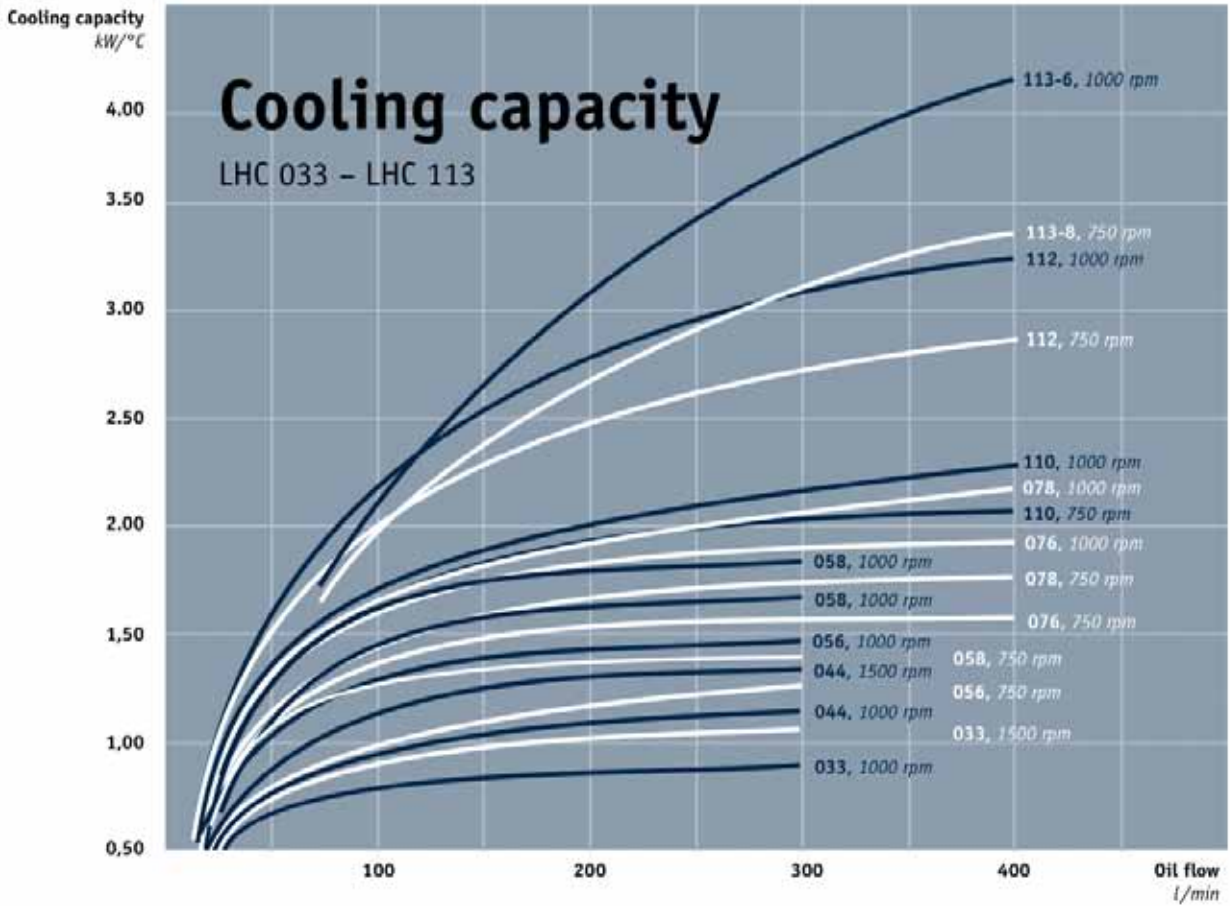

Key for LHC and LHC2 air oil coolers

All positions must be filled in when ordering

EXAMPLE:

LHC2 - 016 - B - 50 - S20 - S - Z

1 2 3 4 5 6 7

1. AIR OIL COOLER

WITH HYDRAULIC MOTOR = LHC / LHC2

2. COOLER SIZE

007, 011, 016, 023, 033, 044, 056, 058, 076, 078, 110, 112 and 113.

3. HYDRAULIC MOTOR, DISPLACEMENT

No hydraulic motor	= 0
Displacement 8.4 cm ³ /r	= A
Displacement 10.8 cm ³ /r	= B
Displacement 14.4 cm ³ /r	= C
Displacement 16.8 cm ³ /r	= D
Displacement 19.2 cm ³ /r	= E
Displacement 25.2 cm ³ /r	= F
Special	= X

(X: pressure, displacement, installation sizes, etc. must be stated in plain language)

4. THERMO CONTACT

No thermo contact	= 00
40 °C	= 40
50 °C	= 50
60 °C	= 60
70 °C	= 70
80 °C	= 80
90 °C	= 90

5. COOLER MATRIX

Standard	= 000
Two-pass	= T00
Built-in, pressure-controlled bypass, single-pass	
2 bar	= S20
5 bar	= S50
8 bar	= S80
Built-in, pressure-controlled bypass, two-pass*	
2 bar	= T20
5 bar	= T50
8 bar	= T80
Built-in temperature and pressure-controlled bypass, single-pass	
50 °C, 2.2 bar	= S25
60 °C, 2.2 bar	= S26
70 °C, 2.2 bar	= S27
90 °C, 2.2 bar	= S29
Built-in temperature and pressure-controlled bypass, two-pass*	
50 °C, 2.2 bar	= T25
60 °C, 2.2 bar	= T26
70 °C, 2.2 bar	= T27
90 °C, 2.2 bar	= T29

6. MATRIX GUARD

No guard	= 0
Stone guard	= S
Dust guard	= D
Dust and stone guard	= P

7. STANDARD/SPECIAL

Standard	= 0
Special	= Z

Technical specification

FLUID COMBINATIONS

Mineral oil	HL/HLP in accordance with DIN 51524
Oil/water emulsion	HFA, HFB in accordance with CETOP RP 77H
Water glycol	HFC in accordance with CETOP RP 77H
Phosphate ester	HFD-R in accordance with CETOP RP 77H

MATERIAL

Cooler matrix	Aluminum
Fan blades/hub	Glass fibre reinforced polypropylene/ Aluminum
Fan housing	Steel
Fan guard	Steel
Other parts	Steel
Surface treatment	Electrostatically powder-coated

COOLER MATRIX

Maximum static operating pressure	21 bar
Dynamic operating pressure	14 bar*
Heat transfer limit	± 6 %
Maximum oil inlet temperature	120 °C

* Tested in accordance with ISO/DIS 10771-1

COOLING CAPACITY CURVES

The cooling capacity curves in this technical data sheet are based on tests in accordance with EN 1048 and have been produced using oil type ISO VG 46 at 60 °C.

CONTACT OLAER FOR ADVICE ON

- Oil temperatures > 120 °C
- Oil viscosity > 100 cSt
- Aggressive environments
- Ambient air rich in particles
- High-altitude locations

CONNECTION CHART

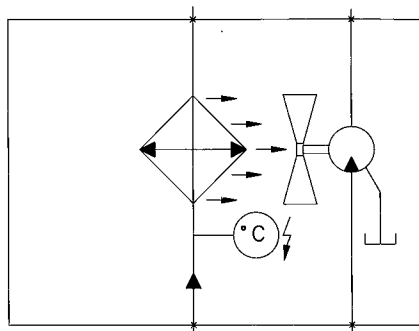

Connection chart for LHC air oil cooler.

The information in this brochure is subject to change without prior notice.



With our specialist expertise, industry knowledge and advanced technology, we can offer a range of different solutions for coolers and accessories to meet your requirements.

Take the next step

- choose the right accessories

Supplementing a hydraulic system with a cooler, cooler accessories and an accumulator gives you increased availability and a longer useful life, as well as lower service and repair costs. All applications and operating environments are unique. A well-planned choice of the following accessories can thus further improve your hydraulic system. Please contact Olaer for guidance and information.



Pressure-controlled bypass valve *Integrated*

Allows the oil to bypass the cooler matrix if the pressure drop is too high. Reduces the risk of the cooler bursting, e.g. in connection with cold starts and temporary peaks in pressure or flow. Available for single-pass or two-pass matrix design.



Stone guard/Dust guard

Protects components and systems from tough conditions.



Temperature-controlled bypass valve *Integrated*

Same function as the pressure-controlled by-pass valve, but with a temperature-controlled opening pressure - the hotter the oil, the higher the opening pressure. Available for single-pass or two-pass matrix design.



Lifting eyes

For simple installation and relocation.



Thermo contact

Sensor with fixed set point. For temperature warnings, and for more cost-efficient operation and better environmental consideration through the automatic switching on and off of the fan motor.



Temperature-controlled 3-way valve *External*

Same function as the temperature-controlled bypass valve, but positioned externally. Note: must be ordered separately.



- in Fluid Energy Management

Global perspective

and local entrepreneurial flair



Olaer is a global player specialising in innovative, efficient system solutions for temperature optimisation and energy storage. Olaer develops, manufactures and markets products and systems for a number of different sectors, e.g. the aircraft, engineering, steel and mining industries, as well as for sectors such as oil and gas, contracting and transport, farming and forestry, renewable energy, etc.

All over the world, our products operate in the most diverse environments and applications. One constantly

repeated demand in the market is for optimal energy storage and temperature optimisation. We work at a local level with a whole world as our workplace – local entrepreneurial flair and a global perspective go hand in hand.

Our local presence, long experience and a wealth of knowledge combine with our cutting-edge expertise to give you the best possible conditions for making a professional choice.