

VALVE CORES

Valve Cores and Valve Core Tools



Valve cores are a cartridge type, spring assisted, check valve assembly that screw into a mating threaded cavity (housing).

A valve core cartridge assembly is comprised of a spring-loaded pin in a tubular housing that has an external thread for mounting into a mating cavity. The valve pin has a soft elastomeric seating washer and an extended actuation shaft. When the actuation shaft is depressed it forces the pin to move off the valve core's housing seat allowing flow to pass through the valve. The core assembly has an external PFA (Perfluoroalkoxy Alkane) static seal to prevent leakage between the valve core and the mating cavity it screws in to.

For example: an automotive tire pressurization valve that is comprised of a valve core mounted in a stem type housing. When a pressurized hose fitting is placed over the tire valve stem the fitting pushes the valve core pin inwards forcing the flow of air to enter the tire. When the hose fitting is removed the valve core's spring and internal tire pressure forces the valve core to close.

There are a number of options for customers wishing to purchase valve cores in both the OEM and aftermarket sectors, see the product part tables on page 5 and Selecting a Schrader Pacific Valve on page 8 for more information.

Most Schrader Pacific® valves have threads and bodies with a standard exterior size allowing for use of universal caps and tools. A Schrader-Pacific valve can be used to control air, nitrogen, R12, R22, R134a, R1234-YF, oils, Halon, SF6, Petrol's, and other controllable media.

Construction information

Materials

Brass, Stainless Steel (spring)

Sealing Materials

Polychloroprene (Neoprene), Nitrile-Butadiene (Nitrile), Hydrogenated Nitrile-Butadiene (HNBR), Fluorocarbon (Viton®, GFLT), Silicone, Epichlorohydrin, Silastic, PFA (Perfluoroalkoxy).

Finish

No Plating, Nickel or Tin plated Brass

Valve cores are defined by their characteristics, and depending on the type selected, these characteristics vary depending on the material, the finish and the design of each valve core.

Opening Pressure: This is the typical air pressure necessary to overcome the resistance of the spring that keeps the valve closed, allowing air to pass through.

Minimum and Maximum Travel: This is the recommended distance the pin can travel without damaging the valve core. This information can be found on specific Schrader Pacific drawings.

Standard thread pitch: 0.206-36 (Tire and Rim: TR-C1)

WARNING: This product can expose you to chemicals, including Lead which is known to the State of California to cause cancer or birth defects or other reproductive harm.

All Schrader Pacific® valve cores are compatible with existing SAE, Tire & Rim, ISO and ARI standards, manufacturing valves for air tanks, steel barrels, compressors and other pneumatic containers where dependable automatic valves are needed. Schrader Pacific also offers service tools to install, remove or repair valves.

OEM sales available worldwide in medium to high quantities.
Application specific orders welcomed.

Schrader Pacific offers a range of standard, large bore, airplane and special valve cores through the aftermarket/replacement sector.

Tank Valves

High Pressure Valves

Build Your Own Valve

Valve Cores

Air System Fittings

TPMS (Tire Pressure Monitoring System)

Couplers and Plugs

Schrader Pacific reserves the right to change any of the following specifications without notice. This document is meant to be used as reference only. For more specific information, or information regarding cores not listed here, please contact Schrader Pacific.



Due to the variety of operating conditions or applications, the customer is responsible to perform their own testing to insure performance, safety and warning requirements for the intended application.

Air Conditioning



Standard Air

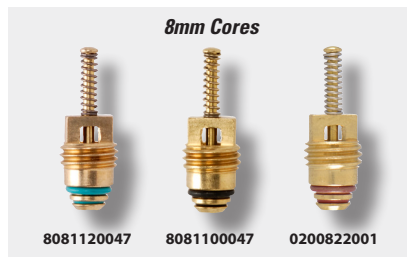
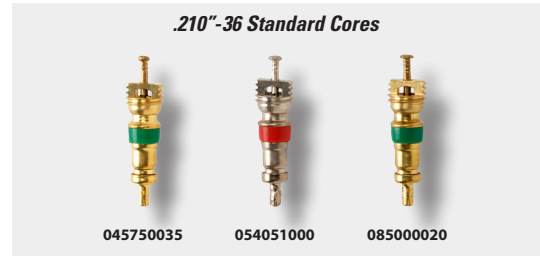

Fuel System Cores



Miscellaneous



Valve Core Assortment Kit Part# 0200000001

For application details contact your Schrader Pacific Sales representative.

WARNING: This product can expose you to chemicals, including Lead which is known to the State of California to cause cancer or birth defects or other reproductive harm.

Air Conditioning

Part No. <small>1,000 pack</small>	Opening Pressure <small>PSIG</small>	Max. Working Pressure <small>PSIG</small>	Temp Range <small>°F</small>	Installation Torque <small>IN.-LBS</small>	Core Type	Dynamic Sealing Surface	Surface Finish
8080570047	40	800	-20 to 220	3-5	Standard	Neoprene	Plated
8080580047	40	800	-20 to 220	3-5	Standard	Neoprene	Unplated
8081070047	40	800	-10 to 300	3-5	Standard	HNBR	Plated
8081100047	N/A	800	-40 to 245	10-20	8mm	Neoprene	Unplated
8081120047	N/A	800	-40 to 245	10-20	8mm	HNBR	Unplated
8081210047	N/A	800	-40 to 245	15-30	10mm	Neoprene	Unplated
8081220047	N/A	800	-40 to 245	15-30	10mm	HNBR	Unplated
0200822001	N/A	800	-40 to 300	10-20	8mm	HNBR	Unplated
0200842001	N/A	800	-40 to 300	15-30	10mm	HNBR	Unplated
8081530070	N/A	800	-40 to 245	5-10	JRA	HNBR	Plated
8081540070	N/A	800	-40 to 245	5-10	JRA	HNBR	Unplated
8081910047	N/A	400	-40 to 210	3.5-7	Std. European	Chloroprene	Plated
8089000070*	N/A	400	-40 to 210	6.2-9.7	8mm European	Chloroprene	Plated

Standard Air

Part No. <small>1,000 pack</small>	Opening Pressure <small>PSIG</small>	Max. Working Pressure <small>PSIG</small>	Temp Range <small>°F</small>	Installation Torque <small>IN.-LBS</small>	Core Type	Dynamic Sealing Surface	Surface Finish
045750035	25 to 35	200	-40 to 165	3-5	Standard	Nitrile	Unplated
054051000	90	250	-65 to 300	3-5	Standard	Silicone	Plated
085000020	60 to 75	300	-40 to 225	3-5	Standard	Nitrile	Unplated

Fuel

Part No. <small>1,000 pack</small>	Opening Pressure <small>PSIG</small>	Max. Working Pressure <small>PSIG</small>	Temp Range <small>°F</small>	Installation Torque <small>IN.-LBS</small>	Core Type	Dynamic Sealing Surface	Surface Finish
8080721047	40	500	0 to 450	3-5	Standard	Viton [®]	Plated
8080731047	40	500	-40 to 450	3-5	Standard	Viton [®]	Plated
8080801047	40	500	-30 to 400	3-5	Standard	GFLT	Plated
061810020	45	500	-20 to 350	3-5	Standard	Viton [®]	Unplated
0200841001	N/A	800	-40 to 400	15-30	10mm	Viton [®]	Unplated

Miscellaneous

Part No. <small>1,000 pack</small>	Opening Pressure <small>PSIG</small>	Max. Working Pressure <small>PSIG</small>	Temp Range <small>°F</small>	Installation Torque <small>IN.-LBS</small>	Core Type	Dynamic Sealing Surface	Surface Finish
015660113	0.2 to 4	150	-10 to 165	3-5	Standard	Nitrile	Plated
062310100	50	200	-65 to 300	3-5	Large Bore	Red Silicone	Plated
060350001**	50	550	-65 to 350	3-5	Standard	Silastic	Plated
099141117	80	4000	-40 to 225	3-5	Standard	Nitrile	Plated
8039700047	N/A	200	-2 to 167	3-5	Standard	Nitrile	Plated
8588900047	23-28 (approx.)	n/a	n/a	3-5	Standard	Nitrile	Plated

*same as 37478-52

**no longer certified for aircraft use

1,000 pack part numbers shown. Other pack sizes available. Contact customer service or an authorized distributor for more information.

Due to the variety of operating conditions or applications, the customer is responsible to perform their own testing to insure performance, safety and warning requirements for the intended application.



Installation Guide

Scope

This engineering guide is to cover the installation and application recommendations for the use of standard valve cores in all automotive and industrial applications.

Product Type

Standard valve cores are defined by ISO (International Standards Organization), TRA (Tire & Rim Association) and ARI (American Refrigeration Institute) relative to the application for air, fluid and gas service devices.

Installation Torque

The installation torque for standard cores per ISO is 3 – 5in. lbs. [0.34 – 0.57 Nm]. Breakaway torque is not an accurate way to verify the installation torque due to material, lubricants and other conditions that may exist.

Torque Drivers

For automated assembly, it is recommended to use only drafted torque driver bits that are more forgiving reducing the damage to the valve core creating chips that may cause leaks in the final assembly. (Specifications shown below.)

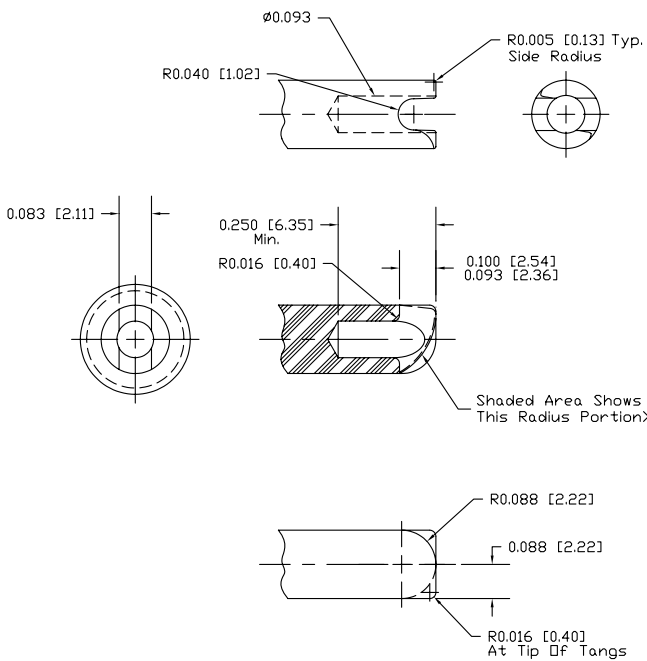

Temperature Sensitive

It is not recommended to submit the Valve Core assembled into a Valve Body to accelerated temperatures above the normal operating temperatures such as brazing and oven curing for paints and other coating processes. Permanent damage to the seals may occur causing long term sealing problems.

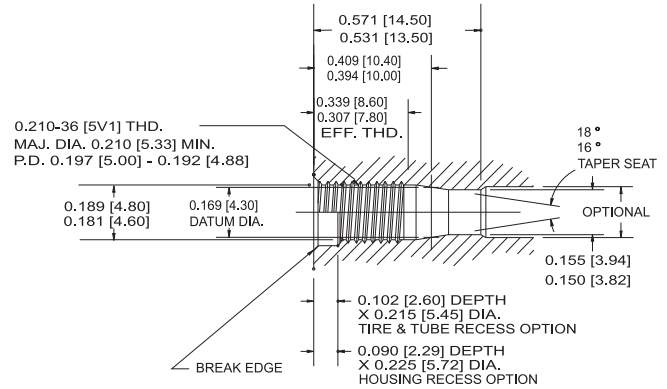

Standard Core Drilling

Core chamber must conform to ISO 7442 and threads must be to ISO 4570/1

All Valve Bodies must conform to the TRA, ISO or ARI recommended standard core drilling to ensure proper seating of the Valve Core to meet the sealing and pin height requirements of the individual industry standards.

Cleanliness

Cleanliness for the Valve Cores and Body must be less than 0.015 grams per 100 parts after final assembly. Using improper torque drivers can cause contamination.

Surface Finish

The importance of a properly machined housing cannot be overemphasized. The surface finish of the taper seat must be smooth without any machining tool marks. The proper taper seat angle must also be met to ensure proper compression of the outer Valve Core sealing material.

Serviceability

No Valve Cores are to be reused under any circumstances after removal from the Valve Body. Always install a new Valve Core when servicing the system for air, fluid or gas applications.

WARNING: This product can expose you to chemicals, including Lead which is known to the State of California to cause cancer or birth defects or other reproductive harm.

The right tools for the job

Proper core installation is important to ensure correct pin height and leak free performance. Schrader Pacific recommends that tools designed specifically for the task be used.

Standard core tap/drill components.

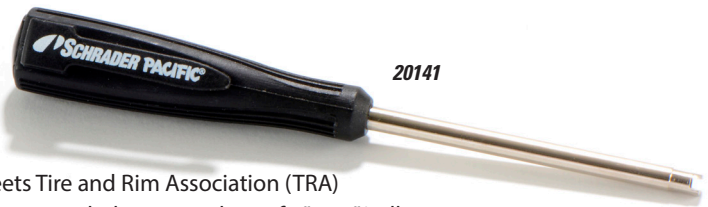

Meets Tire and Rim Association (TRA) recommended torque values of 3" to 5" in-lb. on TRC1 valve cores. Serves as both a core remover and installer. Order individually. (One per box)

Standard handle core tool for standard valve cores.



4-way valve core tool

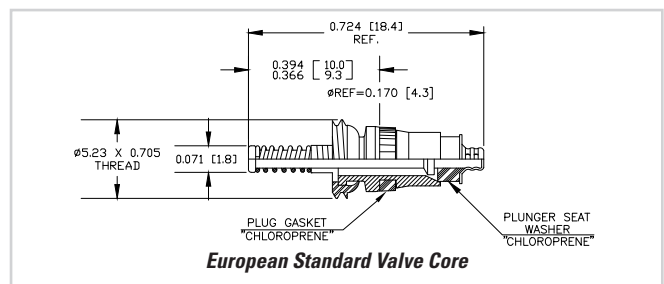
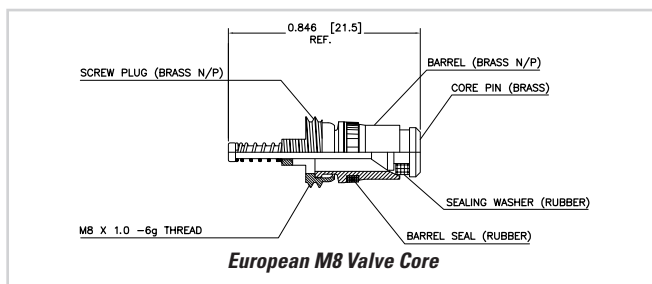
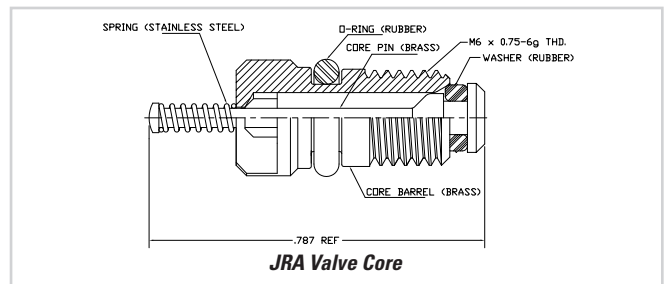
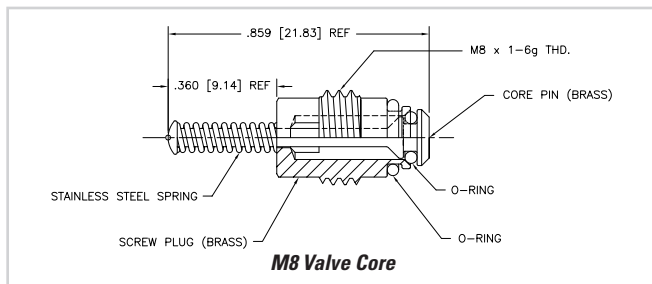
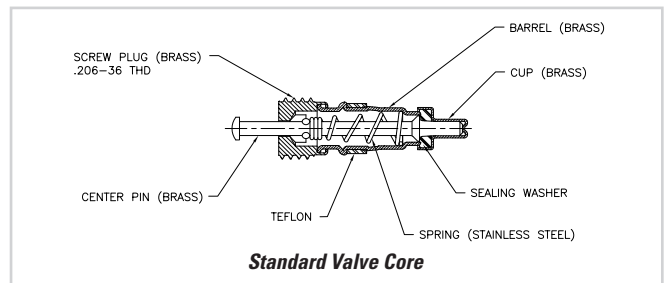
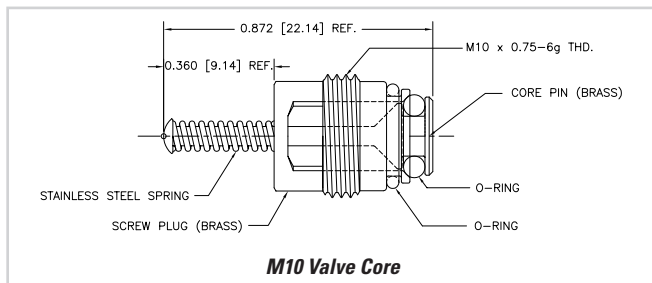

Due to the variety of operating conditions or applications, the customer is responsible to perform their own testing to insure performance, safety and warning requirements for the intended application.

SELECTING A SCHRADER PACIFIC VALVE

There are more than 25 different valve constructions in the Schrader Pacific catalog; how does an engineer decide which is best for his application?

This short guide is intended to help our customers consider each of the various, selecting from the choices the best choice for the application. The principal determinants for the choice are: working fluid, service temperature, system pressure, and flow rate. While there are a few other valve differences, these are not significant except in special applications.

1. WORKING FLUID

The choice of valve will first need to consider the working fluid. Schrader Pacific valves are available with Chloroprene, Silicone, Nitrile, HNBR, EPDM, GFLT and Viton seal materials. When considering the correct valve to specify, consider the chemical resistance of these various rubber compounds to the working fluid and select among those most compatible. Schrader standard cores have Teflon outer seals, these will be compatible with any working fluid. AC applications generally utilize either chloroprene, EPDM or HNBR seal materials. Petroleum fluids, such as gasoline, diesel fuel and oil, will generally use Viton or GFLT seals. In addition to the seal material choice, Schrader Pacific valves are available either nickel plated or un-plated, as some fluids may be reactive to the raw brass material. Remember that the consideration of working fluid includes both the service fluid and any additives and supplements in the fluid such as refrigerant lubricants and dies, or ethanol in fuels. Also, common contaminants that are regularly found in some working fluids such as water or peroxide in fuel or should be considered.

2. SERVICE TEMPERATURE

Generally the only valve component subject to service temperature limits is the seal material. The combination of service temperature and working fluid will drive the choice of seal material. For example, chloroprene is a good choice for some AC systems as long as the service temperature does not exceed 120° C, in which case HNBR or EPDM may be chosen. The Schrader Pacific catalog gives service temperature limits

for various valves, these are steady-state temperatures, short term exposure beyond these limits may be considered. Because the exact nature of these excursions can vary greatly, Schrader Pacific recommends our customers verify the suitability of any choice by the customer in his application. Remember that rubber compounds have low temperature limits that should also be considered if the application will expose the valve to temperatures below -15°C.

3. SYSTEM PRESSURE

While Schrader Pacific produces a high pressure valve for applications up to 4000 psi, most valves have working pressure limits between 200 psi and 800 psi. As was the case for service temperature transient and short term excursions above the listed maximum pressure. The application limits for will be a function of the combined temperature and pressure to which the valve will be exposed, and the duration and frequency of these excursions. Because the exact nature of these excursions can vary greatly, Schrader Pacific recommends our customers verify the suitability of any choice by the customer in his application.

4. FLOW RATE

In general the size of Schrader Pacific valves will be indicative of the flow capacity of the valve: higher flow rates will require larger valves. The Schrader Pacific "standard core" will provide low flow capacity and is used for providing access to fluid systems for system monitoring. Larger valve sizes are available for those applications requiring greater flow.

In addition to the standard production valve information which can be found in the catalog, the Schrader Pacific engineering team is available to discuss any questions regarding valve capabilities and application parameters. Schrader Pacific valves are used in a great many applications with unique system properties; we are pleased to share our experience in these applications to assist in selecting the appropriate valve. However it is important that customers validate the valve application in each system to assure satisfactory performance and durability.



1800-OILSOL
1800-645765

<https://oilsolutions.com.au/>

sales@oilsolutions.com.au

 **SCHRADER PACIFIC**
Advanced Valves

205 Frazier Road
Altavista, Virginia 24517

1.800.345.0578

Schrader-Pacific.com